

West Virginia  
Division of Mining and  
Reclamation



TECHNICAL HANDBOOK

Revised 06/2024

# TECHNICAL HANDBOOK

## INDEX

Chapter 1	Pre-Planning and Sediment Control Structures	01
Chapter 2	Estimating Runoff	07
Chapter 3	Sediment Dams, Embankment Type	74
Chapter 4	Excavated Sediment Dams, Embankment Type	95
Chapter 5	Excavated Sediment Pond, Dugout Type	103
Chapter 6	Gabion Sediment Dam	109
Chapter 7	Crib Sediment Dam	120
Chapter 8	Valley or Head-of Hollow Fills	128
Chapter 9	Side Hill Fills	134
Chapter 10	Durable Rockfills	139
Chapter 11	Diversions	144
Chapter 12	Stream Channel Diversion (Stream Location)	159
Chapter 13	Haulageway or Access Roads	163
Chapter 14	Bench Control Systems	178
Chapter 15	Excavated Sediment Channel	183
Chapter 16	Certification and Inspection	186
Chapter 17	Abandonment Procedures for Sediment Control Structures	190
Chapter 18	Regraded Drainage Control	193
Chapter 19	Water Management Practices	196
	19.1 Determining or Altering Sediment Basin Shape	199
	19.2 Stone Check Dams	200
	19.3 Straw Bale Dike	203
	19.4 Log and Pole Structures	204
	19.5 Filter Fence	206
	19.6 Sediment Trap	210
	19.7 Toe Berm	211
	19.8 Level Spreader	213
	19.9 Skimmer Device	215
	19.10 Perforation	215
	19.11 Rock Riprap	216
	19.12 Pumped Water Management	217
	19.13 Excelsion Blanket	217
	19.14 Mulch Blankets	218
	19.15 Jute Netting	219
	19.16 Netting	220
	19.17 Rock Riprap Flume	221
	19.18 French Drains	223
	19.19 Design Requirements for Rock Riprap	225
Chapter 20	Revegetation	236

# **1** *Pre-Planning and Sediment Control Structures*

## **CONTENTS**

<b>Minimum Requirements</b>	01
Sediment Control	01
Acid Water	02
Land Stabilization	03
Geology	03
Water Disposal	03
Summary	04
<b>Sediment Control Structures</b>	04
Definition	04
Purpose	04
Drainage Area and Site Evaluation and Limitations	05
Sediment	05
Structures in Series	05
Water Quality Standards	05

## PRE-PLANNING AND SEDIMENT CONTROL STRUCTURES

### MINIMUM REQUIREMENTS

Extensive pre-planning is necessary if the conservation of soil and water resources in surface mined areas is to be effectively undertaken. Pre-planning must be done prior to the beginning of surface mining operations with the aim to eliminate or reduce some of the foreseeable problems associated with the specific area to be mined. The problems associated with surface mining are many and varied, however, the primary aim of pre-planning should be to arrive at a satisfactory method of site drainage, reducing sedimentation loads, preventing acid water discharge and meeting effluent limitations are three very important items to consider when working on a comprehensive drainage plan.

Other areas that must be considered during the planning stage are land stabilization, geology and water disposal. Consideration in pre-planning should be given to total environmental effects on air, wildlife, fish, plants and aesthetics with a desire for improved land capability upon completion of mining. Possible detrimental effects of surface mining can be prevented if careful pre-planning coupled with good mining practices and effective reclamation work is carried out.

In the following sections, some of the major problem areas and their possible solutions are discussed. Each should be considered during the pre-planning phase.

### 1.1 SEDIMENT CONTROL

Sediment is one of the greatest polluters of water and causes more offsite damage and problems than any other aspect of surface mining.

A number of factors influence erosion and sedimentation rates. Among these are:

1. Type of soil and cover
2. Erodibility of the soil
3. Degree of slope
4. Length of slope
5. Amount and rate of rainfall
6. Climate
7. Distance from source
8. Degree of filtering between source and sampling point.

In areas with established vegetated cover, the sediment producing potential is reduced by the absorption of raindrop impact energy and by decreasing the amount and velocity of runoff.

Steepness affects the potential energy that runoff has to transport sediment and the stability of the particles subject to erosion. The longer the slope, the more likely that runoff will cause the development of rills and gullies, thereby greatly increasing the erosion potential.

Some of the physical properties of soil that influence erodibility are: texture, percentage of coarse fragments especially on the surface soil structure, mineralogy, amount and type of clay, organic content and depth of soil.

The sediment storage value of 0.125 acre-feet per acre of disturbed area is based on studies by the U. S. Forest Service and the Soil Conservation Service. As sediment structure is installed and monitored, more knowledge will be gained to provide a better basis for storage values. It is imperative that provisions for cleanout and maintenance of all sediment structures be provided.

There are various methods that may be used to eliminate sediment problems provided they are skillfully planned and applied.

1. Sediment structures shall be installed and maintained by using the best technology currently available to remove sediment from streams and drainageways leaving the disturbed area.
2. The smallest practical area of land should be exposed at any one time during the mining phase. This means progressive backfilling and reclamation. Exposure should be kept to the shortest practical period of time.
3. Final dressing and grading shall be done progressively, and temporary vegetation and mulching shall be done where permanent vegetation establishment is delayed.
4. Spoil material shall in all cases be kept out of the stream channel. Stream relocation should be avoided if at all possible.
5. Adequate watertight conduits or bridges shall be used where haulage roads must cross natural drainways. Again, care shall be taken to ensure that spoil does not get into the stream where such structures are built. Road banks shall be mulched or seeded immediately as construction progresses.
6. Diversions may be installed above the highwall to divert upland runoff around the disturbed area to a suitable crossing of the disturbed areas.
7. Rocklined ditches or other suitable structures shall be provided where necessary to convey concentrated flows down steep slopes.
8. Toe berms or other acceptable filter devices shall be constructed near the toe of spoil banks to slow down sheet flow and trap sediment before leaving the site. Vigorous vegetation shall be maintained on the berm.
9. Types of Water Management Practices may be used to assist in sediment control. However, they will not be considered as substitutes for sediment dams, excavated sediment ponds or other approved storage structures.
10. Discharge Structures - Discharge from sediment control structures, (temporary and permanent structures), diversions, stream channel diversions, etc., shall be controlled by energy dissipaters, riprap channels and other devices approved by the Director to reduce erosion, to prevent deepening or enlargement of stream channels and to minimize disturbance of the hydrologic balance. Discharge structures shall be designed according to standard engineering procedures.

## 1.2 ACID WATER

The keys to acid water formation are: pyrite or other acid- forming compounds, a continuous supply of oxygen and water. Remove one of the keys, oxygen, for example, prevents acid water generation. Control methods for the abatement of acid water shall be as follows:

1. Intercept surface water that may flow into the pit by constructing diversion above the highwall.
2. When potentially acid producing materials are identified, a plan must be developed for handling these materials in order to prevent the production of acid water.

3. Water treatment facilities shall be installed to treat acid water; treatment may include chemical processes for the neutralization of the acid such as limestone spreaders, limestone drums, bricks, etc.

### 1.3 LAND STABILIZATION

Land stabilization as used here means long term stability of soil and rock against slides, slips and mud flows. It is only through cycles of wet, dry, freeze and thaw periods that true stability can realistically be judged.

Stability is controlled by:

1. Establishment of vegetative cover
2. Outer slope of regraded spoil
3. Regraded drainage
4. Bedrock lithology and stratigraphy
5. Soil and rock content of the spoil

Slips and landslides are caused by the top-heavy nature of a soil mass and usually occur when the soil becomes saturated. Uncontrolled spoil placements and uncontrolled drainage result in unstable conditions.

### 1.4 GEOLOGY

The geology of the area must be known if a satisfactory plan is to be developed for water control and disposal, sediment pollution control, acid drainage control and successful establishment of a productive vegetative cover. Geologic factors indicate:

1. Potential acidity
2. Potential slope stability
3. Potential stoniness of spoil
4. Dip of coal strata

The strike and dip of the coal strata must be known in order to plan an effective drainage plan.

Drainage plans can be enhanced by taking advantage of the dip (or slope) of coal seams in determining which way to drain the benches. This also permits determining which natural drainways to use.

### 1.5 WATER DISPOSAL

Collection and delivery of water to a safe and stable outlet is an important aspect in developing a drainage plan. Water will always occur, and provisions must be made to handle it at all times. Water disposal usually will be connected with bench and diversion drainage and the methods of getting the water to a natural drainway.

Water shall be directed to and discharged through an adequate outlet. The outlet may be a natural drainway, a vegetated area or some other stable constructed watercourse.

Bench drainage may be accomplished by waterways draining to an outlet in the direction of bench slope. In no case will the water be discharged over the bench crest unless protected against concentration of water by the use of structural means (pipes, riprap, concrete, etc.).

It must be recognized that all control measures are not equally effective at all sites. Diversions may work well at some locations but may be ineffective at others. Rocklined chutes, ditches or pipe drop spillways shall be required at many places in lieu of natural or grassed waterways. The methods of controlling erosion and sediment must be site specific.

Where possible sediment structures should be located before drainageways reach the mainstream. A good rule to remember is to locate them as close to the source as possible. Where feasible, they should be of the diversion type. This will keep sediment storage accumulations out of the main watercourses. After reclamation is complete, the diversion may be closed, and sediment deposits isolated from further flows. Land disturbed by previous surface mining operations that is not stabilized should be included when determining the disturbed area above sediment structures.

## 1.6 SUMMARY

All overburden material subject to disturbance should be classified for potential acidity and a plan developed for handling and placing of material in such a manner that the resulting mine soil of the regraded surface will support the planned vegetation. Massive rocks and potentially acid-producing strata shall be placed where it is not a part of the finished surface.

The after-mining land use possibilities of the area affected should be based upon the properties of the overburden compatibility with adjacent land uses and the needs and desires of the landowner.

Water capable of supporting fish and other desirable aquatic life shall be the goal where impoundments are planned and are proposed to remain for future land use.

Good planning, design, installation and maintenance of erosion and sediment control measures utilizing the best technology currently available will provide for effective control at all sites. However, it must be recognized that there are locations where the physical characteristics of the land are such that effective erosion and sediment control system cannot be provided. When these conditions exist, consideration for surface mining may be denied.

## SEDIMENT CONTROL STRUCTURES

### 1.7 DEFINITION

Sediment control structures shall be constructed in appropriate locations in order to control sedimentation. All runoff from the disturbed area shall pass through a sedimentation pond(s) such as, but not limited to, sediment dams, embankment type; excavated sediment dams, embankment type; excavated sediment pond, dugout type; crib sediment dam; gabion sediment dam; and bench control systems.

### 1.8 PURPOSE

To preserve the capacity of reservoirs, ditches, canals, diversions, waterways and streams and to prevent undesirable deposition on bottom lands, in channels or waterways, and other areas by providing basins for the deposition and storage of silt, sand, gravel, stone and other sediment.

## **1.9 DRAINAGE AREA AND SITE EVALUATION AND LIMITATIONS**

The contributing watershed above the site shall have an adequate plan for providing protection against erosion of disturbed areas. This plan shall provide for rapid revegetation of the disturbed areas in order to stabilize the area as quickly as possible after it has been disturbed. The plan is also to include utilization of one or many methods of "Water Management Practices" in Chapter 19 to assist the overall erosion and sedimentation control system. It is required to prevent excessive sedimentation from exceeding the design capacity of the sediment dam. All areas disturbed during the mining operation in the watershed shall be revegetated according to West Virginia Surface Mining Regulations.

### **1.10 SEDIMENT**

The sediment pool shall have a minimum capacity (from the lowest elevation in the reservoir to the crest of the principal spillway) to store 0.125 acre-feet per acre of disturbed area in the drainage area. The disturbed area includes all land affected by previous operation that is not presently stabilized; all land that will be affected during the surface mining operations and all reclamation work; and may include all other lands which have been disturbed by timber operations, construction operations, other surface mining operations, etc. The basin shall be cleaned out when the sediment accumulation approaches sixty percent (60%) of the design capacity. The design and construction drawings shall indicate the corresponding elevation.

### **1.11 STRUCTURES IN SERIES**

When structures are built in series, the principal spillway and emergency spillway sizes for the lower structure shall be based on the total drainage area above the lower structure, the required storage for sediment for any structure shall be based on the disturbed area in the uncontrolled drainage area above that structure.

When an upstream structure exists, a lower structure in series must be designed considering failure of the upstream structure. The design shall consider the principal spillway, emergency spillway, freeboard, etc.

Construction must be completed on all downstream structures prior to construction of an upper structure in a series.

### **1.12 WATER QUALITY STANDARDS**

Discharges from sediment control structures, which control areas disturbed by surface mining operations, must meet all applicable Federal and State laws and regulations. The minimum effluent limitations shall be governed by the standards set forth in the NPDES Program under the Federal Water Pollution Control Act as amended, 33 U.S.C. 466 et. seq. and the rules and regulations promulgated thereunder.

# 2

## *Estimating Runoff*

### **CONTENTS**

General		1
	<i>Definition</i>	1
	<i>Purpose</i>	1
	<i>Scope</i>	1
Factors Affecting Surface Runoff		1
	<i>General</i>	1
	<i>Precipitation</i>	1
	<i>Antecedent Moisture</i>	2
	<i>Hydrologic Soil Groups</i>	2
	<i>Land Use and Treatment</i>	2
	<i>Hydrologic Conditions</i>	2
	<i>Vegetative Cover</i>	3
	<i>Topography</i>	3
Volume of Flood Runoff		3
	<i>Watershed Curve Numbers</i>	3
	<i>Estimating Depth of Runoff</i>	3
Peak Rate of Discharge		3
	<i>Rainfall</i>	3
	<i>Watershed Slope</i>	3
	<i>Peak Discharge</i>	4
Determination of Surface Runoff and Peak Discharge		4
Reference		5
<b>Exhibits</b>		6

## ESTIMATING RUNOFF

### 2.1 GENERAL

#### 2.1.1 Definition

Estimating runoff is the process of determining the volume or peak rate of runoff, from a given watershed for the design storm, or the safe yield expected from the watershed.

#### 2.1.2 Purpose

This section establishes procedures for estimating depth and peak rates of runoff for use in designing erosion and sediment conservation measures for surface mining operations.

#### 2.1.3 Scope

1. The procedures for determining yield and peak rates are applicable to drainage areas of 0 to 500 acres.
2. For larger, greater than 500 acres, or those having special situations, reference should be made to the Soil Conservation Service National Engineering Handbook, Section 4, Hydrology.
3. This standard establishes the minimal acceptable procedure in estimating runoff in predominantly rural or agricultural areas in West Virginia.
4. Tables and charts are included for a quick and reliable way to estimate peak rates of discharge and associated runoff volumes for a range of rainfall amounts, soil types, land use, cover conditions and average watershed slope.

### 2.2 FACTORS AFFECTING SURFACE RUNOFF

#### 2.2.1 General

Precipitation, whether it occurs as rain or snow, is the potential source of water that may run off the surface of small watersheds. The kind of soil and type of vegetative cover have a major effect on the amount of precipitation that runs off. Mechanical treatment on a watershed, along with its topography and shape, affect the rate at which water runs off. The combined effect of soil, vegetative cover and conservation practices on the amount of rainfall that runs off the watershed are represented by "runoff curve numbers" (CN's). (Exhibit 2-2).

#### 2.2.2 Precipitation

The highest rates of runoff from small watersheds are usually caused by intense rainfall. The intensity of rainfall affects the rate of runoff more than it does the volume of runoff. Intense rainstorms that produce high rates of runoff in small watersheds usually do not extend over a large area. Therefore, the same intense rainstorm that causes flooding in a small tributary is not likely to be the one that will cause major flooding in a main stream that drains several hundred square miles.

The intensity of rainfall varies considerably during the storm period. The Type II storm distribution is typical of the more intense storms that occur over West Virginia which distribution was developed from U.S National Oceanic and Atmospheric Administration (Weather Bureau) data.

### 2.2.3 Antecedent Moisture Condition

The amount of precipitation occurring in the five days preceding the storm in question is an indication of the antecedent moisture condition (AMC) of the soil. The runoff curve numbers (CN's) for West Virginia in Exhibits 2-2, are for an average antecedent moisture condition (AMC II).

### 2.2.4 Hydrologic Soil Groups

Soil associated with West Virginia have been classified into four hydrologic soil groups as shown in Exhibit 2-3. The hydrologic soil groups, according to their infiltration and transmission rates, are:

1. (Low runoff potential). Soils having high infiltration rates even when thoroughly wetted. These consist chiefly of deep, well to excessively drained sands or gravels. These soils have a high rate of water transmission in that water readily passes through them.
2. Soils having moderate infiltration rates when thoroughly wetted. These consist chiefly of moderately deep to deep, moderately well to well drained soils with moderately fine to moderately coarse textures. These soils have a moderate rate of water transmission.
3. Soils having slow infiltration rates when thoroughly wetted. These consist chiefly of soils with moderately fine to fine texture. These soils have a slow rate of water transmission.
4. (High runoff potential). Soils having very slow infiltration rates when thoroughly wetted. These consist chiefly of clay soils with a high swelling potential, soils with a permanent high water table, soils with a claypan or clay layer at or near the surface, and shallow soils over nearly impervious material. These soils have a very slow rate of water transmission.

### 2.2.5 Land Use and Treatment

In the method of runoff estimating the effects of the surface conditions of a watershed are evaluated by means of land use and treatment classes. Land use is the watershed cover and it includes every kind of vegetation, litter and mulch, and fallow, as well as nonagricultural uses such as water surfaces (lakes, swamps, etc.) and impervious surface (roads, roofs, etc.). Land treatment applies mainly to agricultural land uses and it includes mechanical practices such as contouring or terracing and management practices such as grazing control or rotation of crops. The classes consist of use and treatment combinations actually to be found in watersheds.

### 2.2.6 Hydrologic Conditions

The soils and its hydrologic condition, in most cases, affect the volume of runoff more than any other single factor. The hydrologic condition of the soil is determined by its moisture content at the time of the storm, its humus and organic content and its temperature, and whether or not it is frozen.

### 2.2.7 Vegetative Cover

Vegetation affects runoff in several ways. The foliage and its litter maintain the soil's infiltration potential by preventing the sealing of the soil surface from the impact of the raindrops. Some of the intercepted moisture is so long draining from the plant down to the soil that it is withheld from the initial period of runoff. Another effect is the transpiration of soil moisture from previous rains leaving a greater void in the soil to be filled. Vegetation, including its ground litter, forms numerous barriers along the path of the water flowing over the surface of the land.

### 2.2.8 Topography

The slopes in a watershed have a major effect on the rate of runoff and the peak discharge rate at downstream points.

## **2.3 VOLUME OF FLOOD RUNOFF**

### 2.3.1 Watershed Curve Numbers

The runoff curve numbers for various watershed conditions previously described are listed in Exhibit 2-2. The CN's in this exhibit are for an average antecedent moisture condition (AMC II).

### 2.3.2 Estimating Depth of Runoff

The volume of runoff from a watershed may be expressed as the average depth of water that would cover the entire watershed. The depth is usually expressed in inches. Exhibit 2-6 lists the runoff in inches for a range of rainfall depths and CN's.

## **2.4 PEAK RATE OF DISCHARGE**

### 2.4.1 Rainfall

The average 24-hour precipitation for various frequencies by counties in West Virginia can be obtained from NOAA Atlas 14 (or the most recent Atlas version). Per policy, Determination of Precipitation Total for Design Storms (2-23-18).

2.4.2 The average watershed slope, which is the slope of the land and not the watercourse, can be estimated accurately to place it in one of the three categories (Flat, Moderate or Steep) in Table (2-1). It may be necessary to determine the average slope of the watershed within a greater degree of accuracy in order to obtain a closer estimate of the peak discharge for special measures. (Exhibit 2-5)

TABLE 2-1  
SLOPE FACTORS FOR PEAK DISCHARGE

Average Slope (Slope Factor in Percent)	Range (In Percent)	Actual Slope (Used in Exhibit 2-4 Computations)
Flat 1 *	0-3	1
Moderate	3-8	4
Steep	8 and above	16

\*Level to nearly level

### 2.4.3 Peak Discharge

The peak discharge for a 24-hour duration can be obtained from the peak rates for discharge, Exhibits 2-4, 2-4A.

## 2.5 DETERMINATION OF SURFACE RUNOFF AND PEAK DISCHARGE

Complete the surface runoff and peak discharge computation sheet (Exhibit 2-7) by the step-by-step procedure as outlined below:

- STEP 1. Determine drainage area and land use of the watershed in acres from topographic maps (USGS), aerial photos, or other data. Also, determine the average slope of watershed in percent.
- STEP 2. By using selected design frequency and location of watershed, enter values from Exhibit 2-1 or NOAA Atlas 14 and determine the design rainfall.
- STEP 3. Determine soil types in watershed in acres for each land use from soil maps available in published soil maps and other sources.
- STEP 4. Using Exhibit 2-3, determine for each land use the hydrologic soil group for the soil type summarized in Step 3.
- STEP 5. Determine runoff curve form Exhibit 2-2. Using land use and hydrologic soil groups obtained in Step 1 through step 4, enter Exhibit 2-2 and select a curve number for each land use and hydrologic soil group. Calculate a weighted curve number for the total drainage area.
- STEP 6. To determine the peak discharge for drainage areas of zero to 5 acres, enter Exhibit 2-4A or drainage area 5 to 500 acres; enter Exhibit 2-4 with the watershed slope, curve number, drainage area and design rainfall; interpolation within sheets might be necessary to determine peak discharge.
- STEP 7. Using Exhibit 2-6 determine storm runoff (inches per acre) by using weighted curve number (Step 5) and rainfall (Step 2). Interpolations within the table will be necessary to determine the runoff (inches per acre)

## REFERENCE

1. U. S. Soil Conservation Service. National Engineering Handbook, Section 4, Hydrology.
2. U. S. Weather Bureau. Rainfall-Frequency Atlas of the United States, Weather Bureau Technical Paper No. 40.
3. U. S. Weather Bureau. Probable Maximum Precipitation and Rainfall Frequency Data for Alaska. Weather Bureau Technical Paper No. 47.
4. U. S. Weather Bureau. Rainfall-Frequency Atlas of the Hawaiian Islands. Weather Bureau Technical Paper No. 43.
5. U. S. Weather Bureau. Generalized Estimates of Probable Maximum Precipitation and Rainfall-Frequency Data for Puerto Rico and the Virgin Islands. Weather Bureau Technical Paper No. 42.
6. U. S. Weather Bureau. Climatology of the United States No. 60-4 (California), 60-35 (Oregon), 60-45 (Washington), 60-49 (Alaska), and 60-51 (Hawaii).
7. U. S. Agricultural Research Service. 1963. Hydrologic Data for Experimental Agricultural Watersheds in the United States 1956-59, miscellaneous Publication 945, 611 pp.

**EXHIBIT 2-1**

H Y D R O L O G Y:

Average 24-hour Precipitation for  
Various Frequencies by Counties

County	Frequency (Yrs.)						
	1	2	5	10	25	50	100
Barbour	2.36	2.75	3.50	4.22	4.79	5.30	5.77
Berkeley	2.46	2.97	3.95	4.80	5.50	6.30	6.75
Boone	2.38	2.72	3.48	3.96	4.65	5.00	5.45
Braxton	2.36	2.70	3.44	4.10	4.70	5.10	5.65
Brooke	2.22	2.51	3.21	3.77	4.35	4.77	4.95
Cabell	2.38	2.68	3.42	3.90	4.52	4.92	5.25
Calhoun	2.32	2.63	3.37	3.88	4.56	4.91	5.40
Clay	2.35	2.69	3.45	4.00	4.65	5.04	5.55
Doddridge	2.30	2.62	3.33	3.90	4.57	4.92	5.40
Fayette	2.38	2.75	3.54	4.10	4.75	5.25	5.70
Gilmer	2.33	2.65	3.37	3.95	4.60	4.96	5.47
Grant	2.42	2.88	3.75	4.60	4.98	5.75	6.30
Greenbrier	2.45	2.85	3.75	4.40	4.92	5.60	6.00
Hampshire	2.45	2.93	3.85	4.70	5.20	5.90	6.55
Hancock	2.20	2.50	3.19	3.74	4.30	4.72	4.85
Hardy	2.48	2.94	3.90	4.75	5.40	5.95	6.70
Harrison	2.32	2.66	3.37	4.00	4.65	4.98	5.55
Jackson	2.32	2.60	3.35	3.82	4.45	4.84	5.27
Jefferson	2.50	3.10	4.20	4.95	5.70	6.60	7.00
Kanawha	2.35	2.66	3.44	3.93	4.60	4.96	5.40
Lewis	2.35	2.67	3.40	4.10	4.68	5.10	5.60
Lincoln	2.38	2.70	3.44	3.93	4.58	4.96	5.35
Logan	2.40	2.74	3.50	3.98	4.67	5.10	5.50
McDowell	2.43	2.81	3.64	4.15	4.79	5.32	5.70
Aarion	2.30	2.65	3.36	3.99	4.63	4.97	5.50
Marshall	2.25	2.54	3.25	3.81	4.44	4.82	5.10
Mason	2.34	2.60	3.37	3.83	4.45	4.84	5.12
Mercer	2.45	2.85	3.60	4.25	4.87	5.48	5.85
Mineral	2.41	2.87	3.74	4.55	4.95	5.70	6.25
Mingo	2.42	2.77	3.54	4.00	4.69	5.15	5.52
Monongalia	2.30	2.66	3.37	4.00	4.65	4.97	5.50

EXHIBIT 2-1

HYDROLOGY:

Average 24-hour Precipitation for  
Various Frequencies by Counties

County	Frequency (Yrs.)						
	1	2	5	10	25	50	100
Monroe	2.47	2.89	3.82	4.45	4.97	4.75	6.25
Morgan	2.43	2.93	3.88	4.70	5.10	5.95	6.60
Nicholas	2.39	2.75	3.50	4.20	4.75	5.25	5.75
Ohio	2.24	2.52	3.22	3.79	4.39	4.78	5.00
Pendleton	2.46	2.93	3.85	4.70	5.30	5.85	6.55
Pleasants	2.27	2.54	3.28	3.78	4.42	4.79	5.15
Pocahontas	2.44	2.86	3.75	4.55	4.97	5.70	6.20
Preston	2.35	2.75	3.50	4.20	4.78	5.30	5.75
Putnum	2.34	2.65	3.40	3.86	4.51	4.89	5.25
Raleigh	2.40	2.77	3.56	4.10	4.75	5.25	5.68
Randolph	2.40	2.84	3.61	4.45	4.90	5.55	5.96
Ritchie	2.29	2.58	3.31	3.82	4.50	4.86	5.30
Roane	2.33	2.64	3.37	3.87	4.54	4.89	5.35
Summers	2.43	2.83	3.61	4.30	4.87	5.50	5.90
Taylor	2.34	2.72	3.43	4.10	4.72	5.12	5.65
Tucker	2.39	2.83	3.62	4.45	4.88	5.50	6.00
Tyler	2.28	2.55	3.28	3.80	4.46	4.84	5.20
Upshur	2.37	2.75	3.49	4.22	4.79	5.25	5.77
Wayne	2.42	2.74	3.49	3.95	4.58	4.99	5.40
Webster	2.39	2.76	3.55	4.30	4.82	5.40	5.85
Wetzel	2.28	2.58	3.28	3.85	4.50	4.86	5.25
Wirt	2.29	2.58	3.32	3.80	4.45	4.82	5.20
Wood	2.28	2.55	3.29	3.76	4.37	4.77	5.07
Wyoming	2.41	2.77	3.56	4.07	4.75	5.25	5.65

EXHIBIT 2-2

RUNOFF CURVE NUMBERS (CN<sup>2</sup>S) GENERAL AGRICULTURAL AREAS

Description	Hydrologic Condition	Hydrologic Soil Group			
		A	B	C	D
<u>Fallow</u>					
Straight row	---	77	86	91	94
<u>Row Crops</u>					
Straight row	Poor	72	81	88	91
Straight row	Good	67	78	85	89
Contoured	Poor	70	79	84	88
Contoured	Good	65	75	82	86
Contoured & terraced	Poor	66	74	80	82
Contoured & terraced	Good	62	71	78	81
<u>Small Grain</u>					
Straight row	Poor	65	76	84	88
Straight row	Good	63	75	83	87
Contoured	Poor	63	74	82	85
Contoured	Good	61	73	81	84
Contoured & terraced	Poor	61	72	79	82
Contoured & terraced	Good	59	70	78	81
<u>Close-Seeded Legumes or Rotation Meadow</u>					
Straight row	Poor	66	77	85	89
Straight row	Good	58	72	81	85
Contoured	Poor	64	75	83	85
Contoured	Good	55	69	78	83
Contoured & terraced	Poor	63	73	80	83
Contoured & terraced	Good	51	67	76	80
<u>Pasture or Range</u>					
No mechanical treatment	Poor	68	79	86	89
No mechanical treatment	Fair	49	69	79	84
No mechanical treatment	Good	39	61	74	80
Contoured	Poor	47	67	81	88
Contoured	Fair	25	59	75	83
Contoured	Good	6	35	70	79
<u>Meadow</u>	Good	30	58	71	78

<b>Woods</b>	Poor	45	66	77	83
	Fair	36	60	73	79
	Good	25	55	70	77
<hr/>					
<b>Farmsteads</b>	---	59	74	82	86
<hr/>					
<b>Roads, Including Rights-of-way</b>					
Dirt	---	72	82	87	89
Hard surface	---	74	84	90	92
<hr/>					
<b>Disturbed Areas</b>	---	72	82	87	89
(Surface Mines, Timber Operations, Deep Mines, Bare Acres. . . . .)					

EXHIBIT 2-2

RUNOFF CURVE NUMBERS (CN'S)

URBAN AREAS-DEVELOPMENT COMPLETED AND VEGETATION ESTABLISHED

Description	Hydrologic Soil Group			
	A	B	C	D
Lawns, Parks, Golf Courses, Cemeteries, etc.	39	61	74	80
Pavement and Roofs-Commercial and Business Areas.	98	98	98	98
Row Houses, Town Houses, and Residential with Lot Sizes 1/8 Acre or less.	80	85	90	95
<b>Residential</b>				
Lot sizes of 1/4 acre	61	75	83	87
Lot sizes of 1/2 acre	53	70	80	85
Lot sizes of 1 acre	50	68	79	84
Lot sizes of 2 acres	47	66	77	81

RUNOFF CURVE NUMBERS (CN'S)

URBAN AREAS-DEVELOPMENT UNDER WAY, NO VEGETATION ESTABLISHED

Description	Hydrologic Soil Group			
	A	B	C	D
Newly Graded Area	81	89	93	95
Pavement and Roofs-Commercial and Business Areas.	98	98	98	98
Row Houses, Town Houses, and Residential with Lot Sizes 1/8 Acre or less.	93	96	97	98
<b>Residential</b>				
Lot sizes of 1/4 acre	88	93	95	97
Lot sizes of 1/2 acre	85	91	94	96
Lot sizes of 1 acre	82	90	93	95
Lot sizes of 2 acres	81	89	92	94

EXHIBIT 2-3

---

H Y D R O L O G Y: Soil Names and Hydrologic Soil Groups

---

Albrights - C	Corydon - C	Laidig - C	Ramsey - D
Allegheny - B	Cotago - C	Lakin - A	Rayne - B
Allen (See Gallia)	Craigsville - B	Landes - B	Robertsville - D
Andover - D	Culleoka - B	Latham - D	Rushtown - A
Ashston - B	*Dekalb - C	Leetonia - C	Schaffenaker - A
Atkins - D	Dormont - C	Lehew - C	Sciotoville - C
Barbour - B	Drall - C	Lickdale - D	Sees - C
Basher - B	Duffield - B	Licking - C	Senacaville - B
Belmont - B	Duncannon - B	Lily - B	Sensabaugh - B
Renevola - C	Dunmore - B	Linden - B	Sequatchie (See Chavies)
Berks - C	Dunning - D	Lindsay - C	Shelocta - B
Blago - D	Edgemont - B	Litz - C	Shouns - B
Blairton - C	Edom - C	Lobdell - B	Summers - B
Braddock - B	Elkins - D	Markland - C	Teas (Calvin high base substratum - C)
Brinkerton - D	Elliber - A	Massanetta - B	Tilsit - C
Brooke - D	Ernest - C	Mcgary - C	Tioga - B
Brookside - C	Faywood - C	Meckesville - C	Tygart - D
Buchanan - C	Frankstown - B	Melvin - D	Tyler - D
Calvin - C	Frederick - B	Mertz - C	Upshur - D
Caneyville - C	Gallia - B	Monongahela - C	Vandalia - D
Captina - C	Gilpin - C	Moshannon - B	Vincent - C
Carbo - C	Ginat - D	Muck and Peat - D	Waynesboro - B
Cavode - C	Glenford - C	Murrill - B	****Weikert - C/D
Chagrín - B	Guernsey - C	Muskingum - C	Wellston - B
Chavies - B	Guthrie - D	Nolin - B	Westmoreland - B
Chilhowie - C	Hackers - B	Nolo - D	Wharton - C
Chili - B	Hagerstown - C	Opequon - C	Wheeling - B
Chilo - D	Hazelton - B	Orrville - C	Woodsfield - C
Clarksburg - C	**Holly - B/D	Otwell - C	Zoar - C
Clifton - B	Holston (See Allegheny)	***Philo - B	
Clymer - B	Huntington - B	Pickaway - C	
Cookport - C	Jefferson - B	Pope - B	
Coolville - C	Kanawha - B	Potomac - A	
		Purdy - D	

For Soil variants contact the State Soil Scientist for Hydrologic Group

---

- \* For Dekalb, use B where bedrock is fractured.
- \*\* For Holly, use B is drained, D if undrained.
- \*\*\* For Philo, use C unless water table is lowered by complete drainage system.
- \*\*\*\* For Weikert, use C unless water table is lowered by completed drainage system.

PEAK RATES OF DISCHARGE FOR WATERSHEDS OF 1 TO 5 ACRES  
TYPE II STORM DISTRIBUTION  
SLOPES FLAT

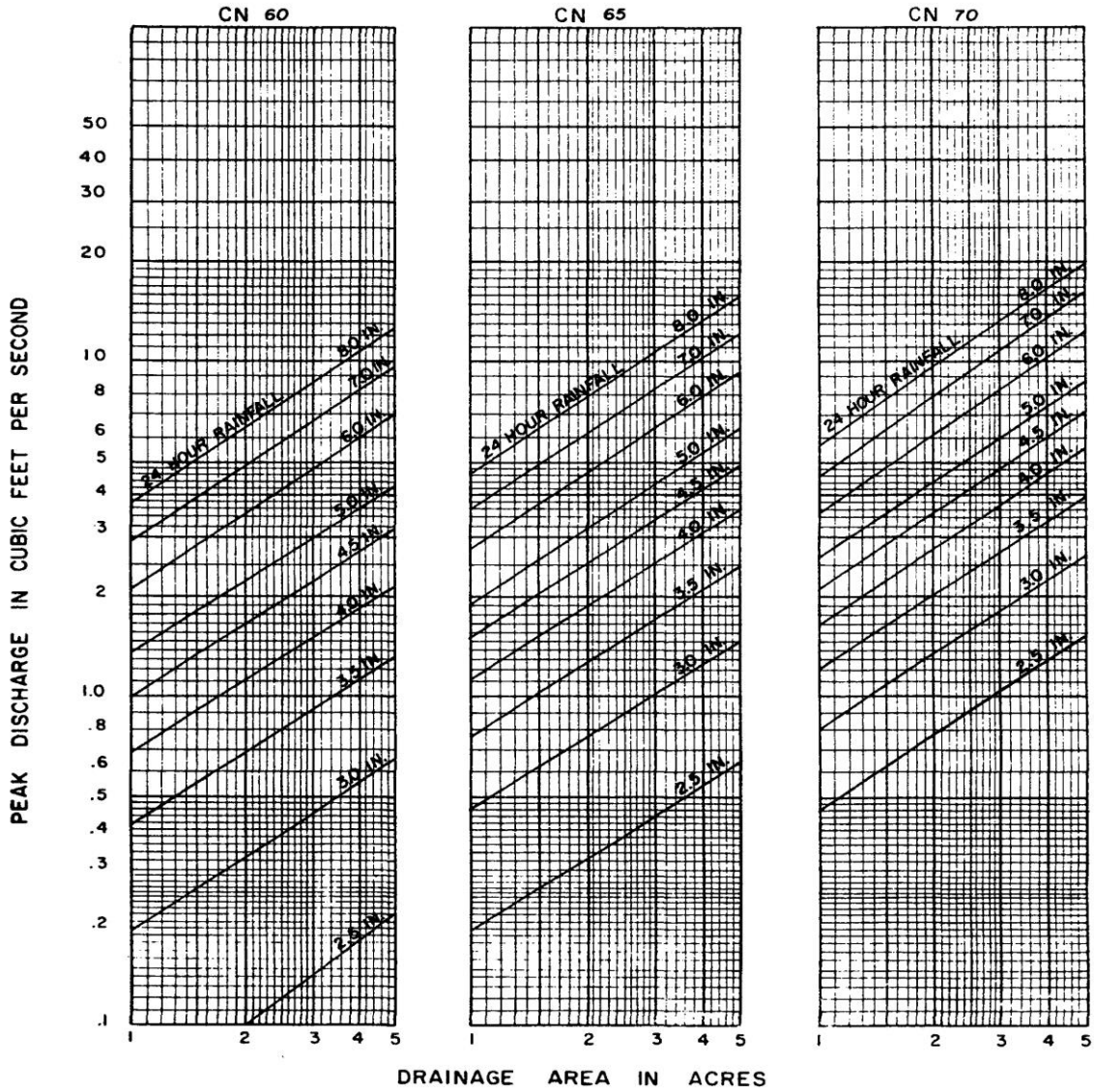

EXHIBIT 2-4A

PEAK RATES OF DISCHARGE FOR WATERSHEDS OF 1 TO 5 ACRES  
TYPE II STORM DISTRIBUTION

SLOPES FLAT

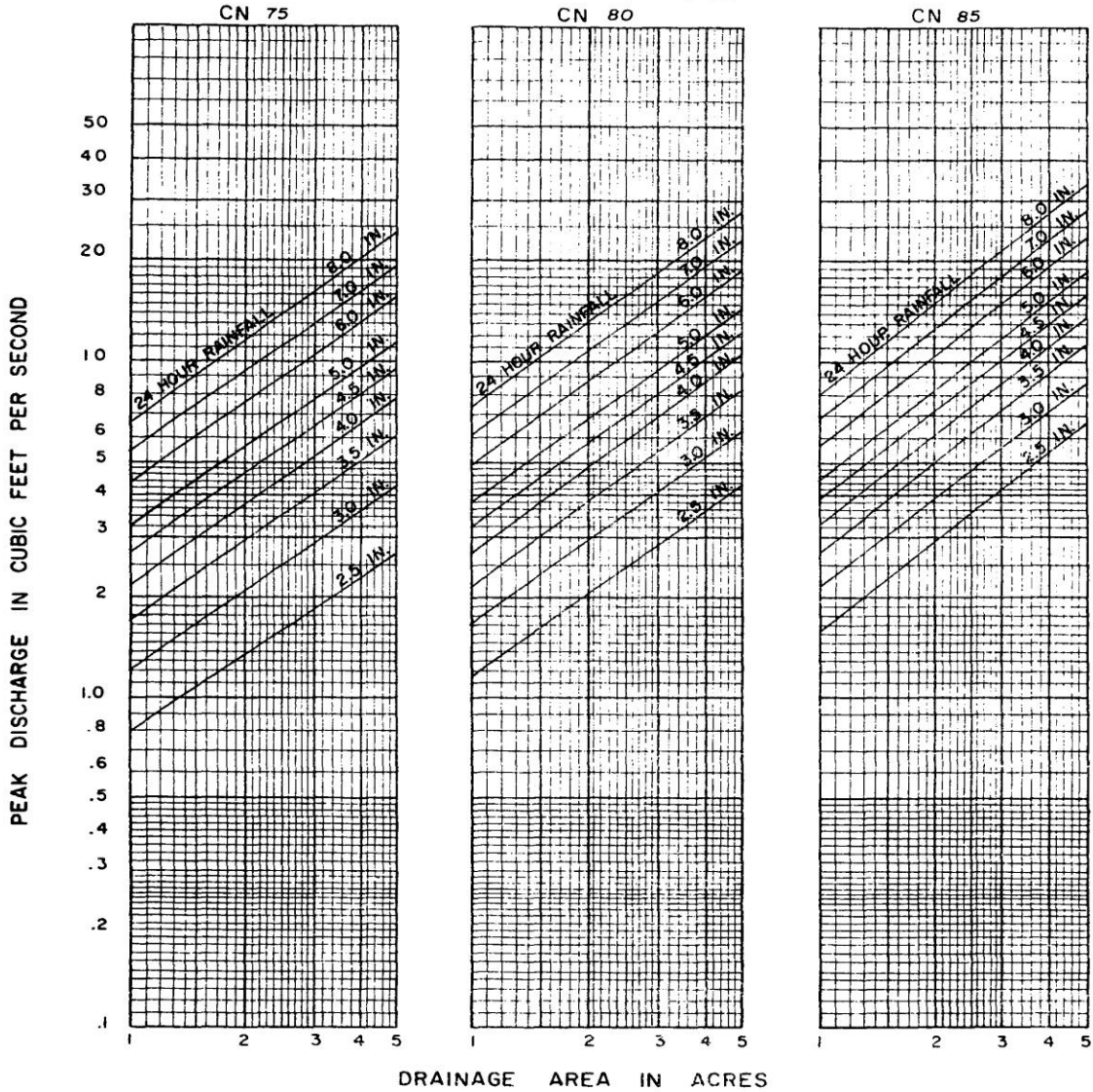

EXHIBIT 2-44

PEAK RATES OF DISCHARGE FOR WATERSHEDS OF 1 TO 5 ACRES  
TYPE II STORM DISTRIBUTION

SLOPES FLAT

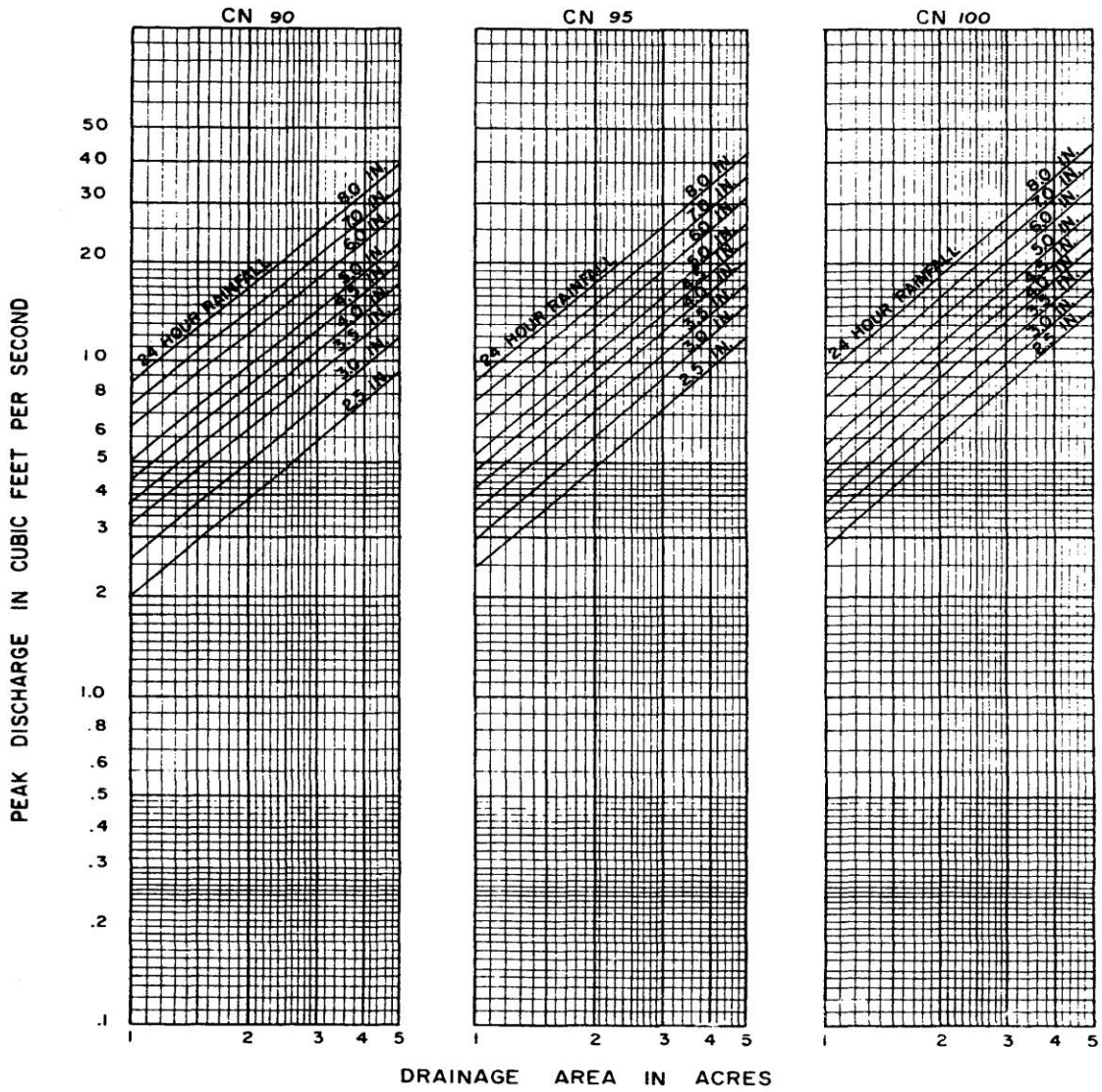

EXHIBIT 2-4A

PEAK RATES OF DISCHARGE FOR WATERSHEDS OF 1 TO 5 ACRES  
TYPE II STORM DISTRIBUTION  
SLOPES MODERATE

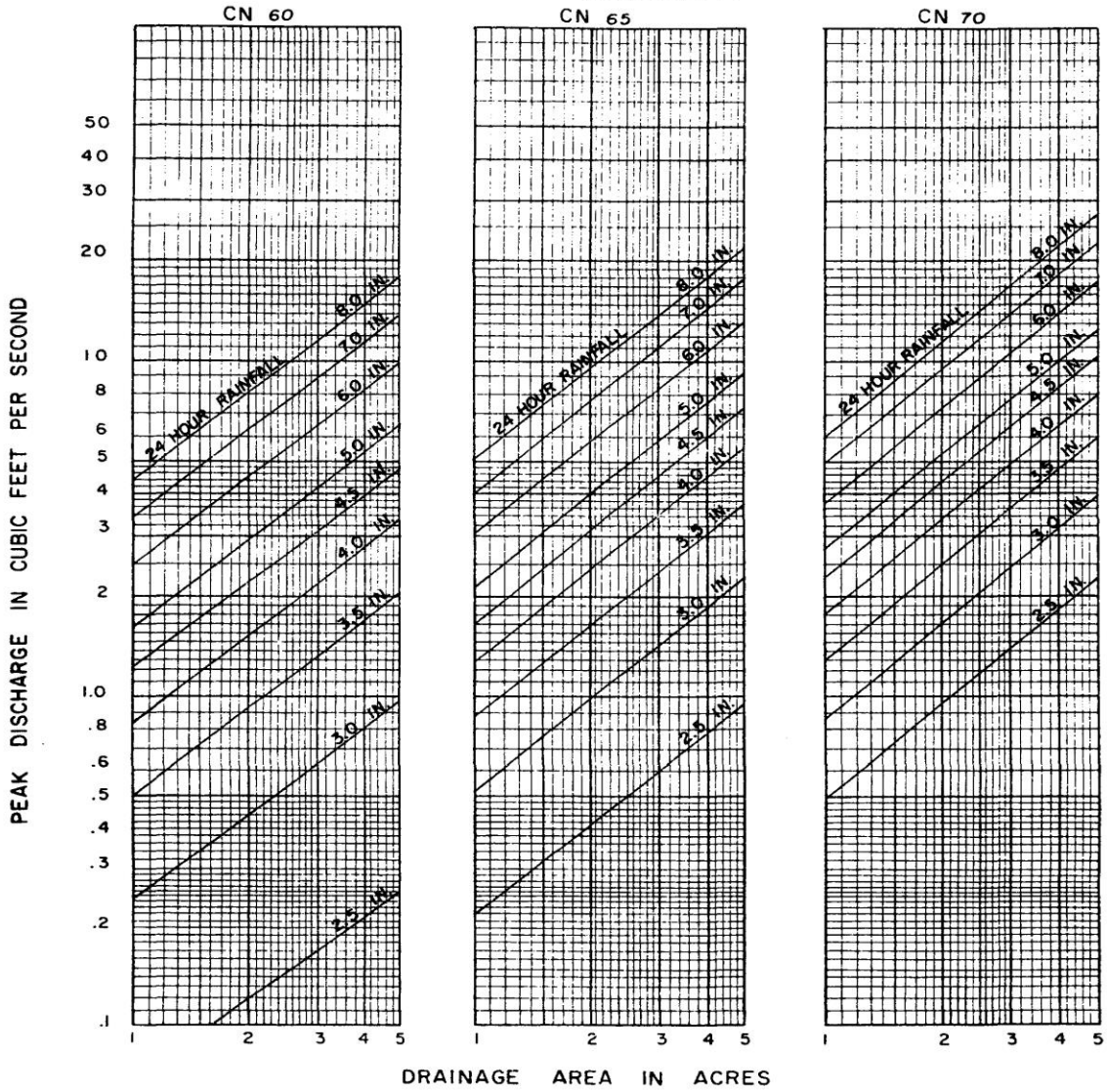

EXHIBIT 2-4A

PEAK RATES OF DISCHARGE FOR WATERSHEDS OF 1 TO 5 ACRES  
TYPE II STORM DISTRIBUTION  
SLOPES MODERATE

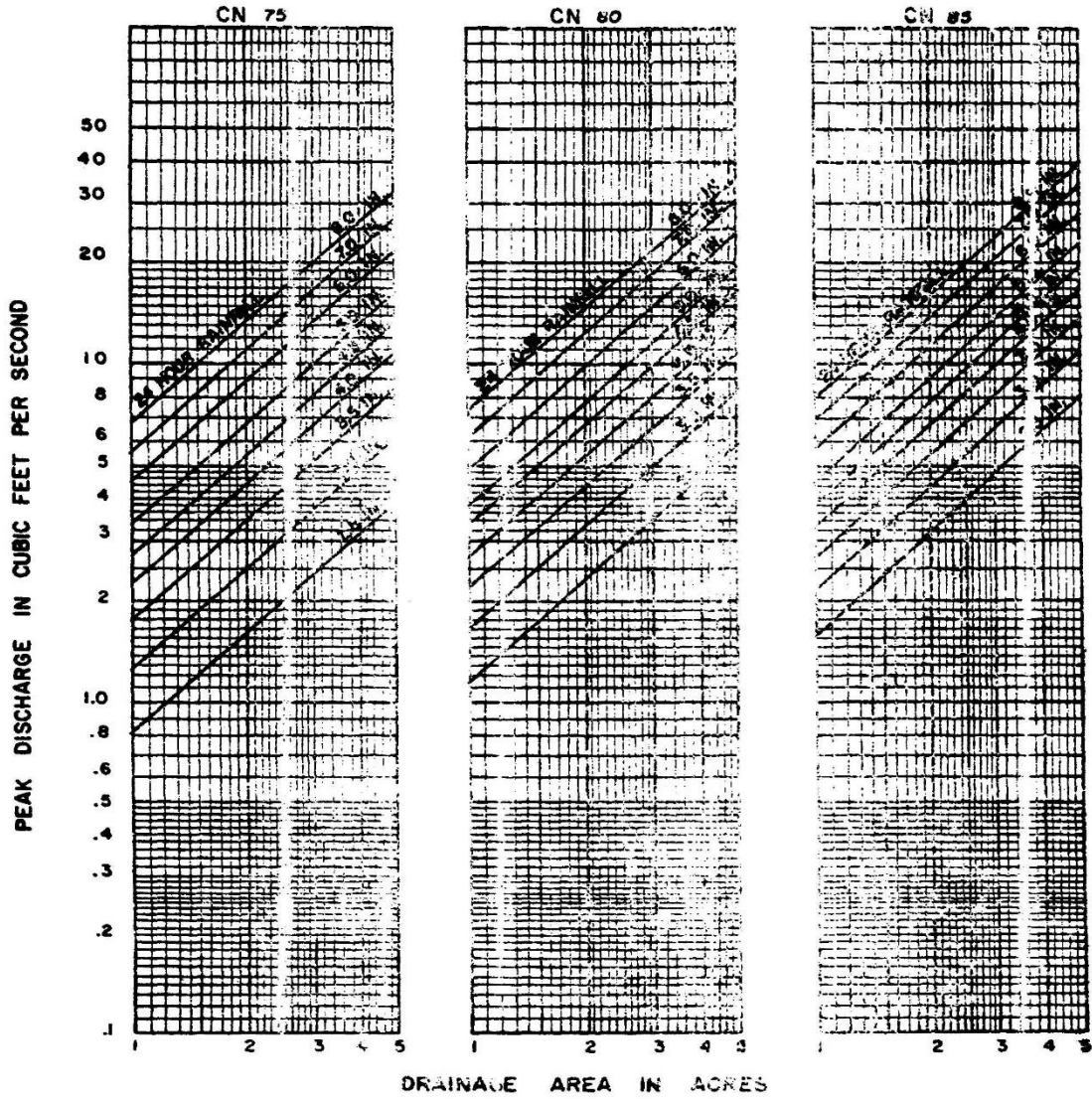

EXHIBIT 2-24

SHEET 5 OF 9

PEAK RATES OF DISCHARGE FOR WATERSHEDS OF 1 TO 5 ACRES  
TYPE II STORM DISTRIBUTION  
SLOPES MODERATE

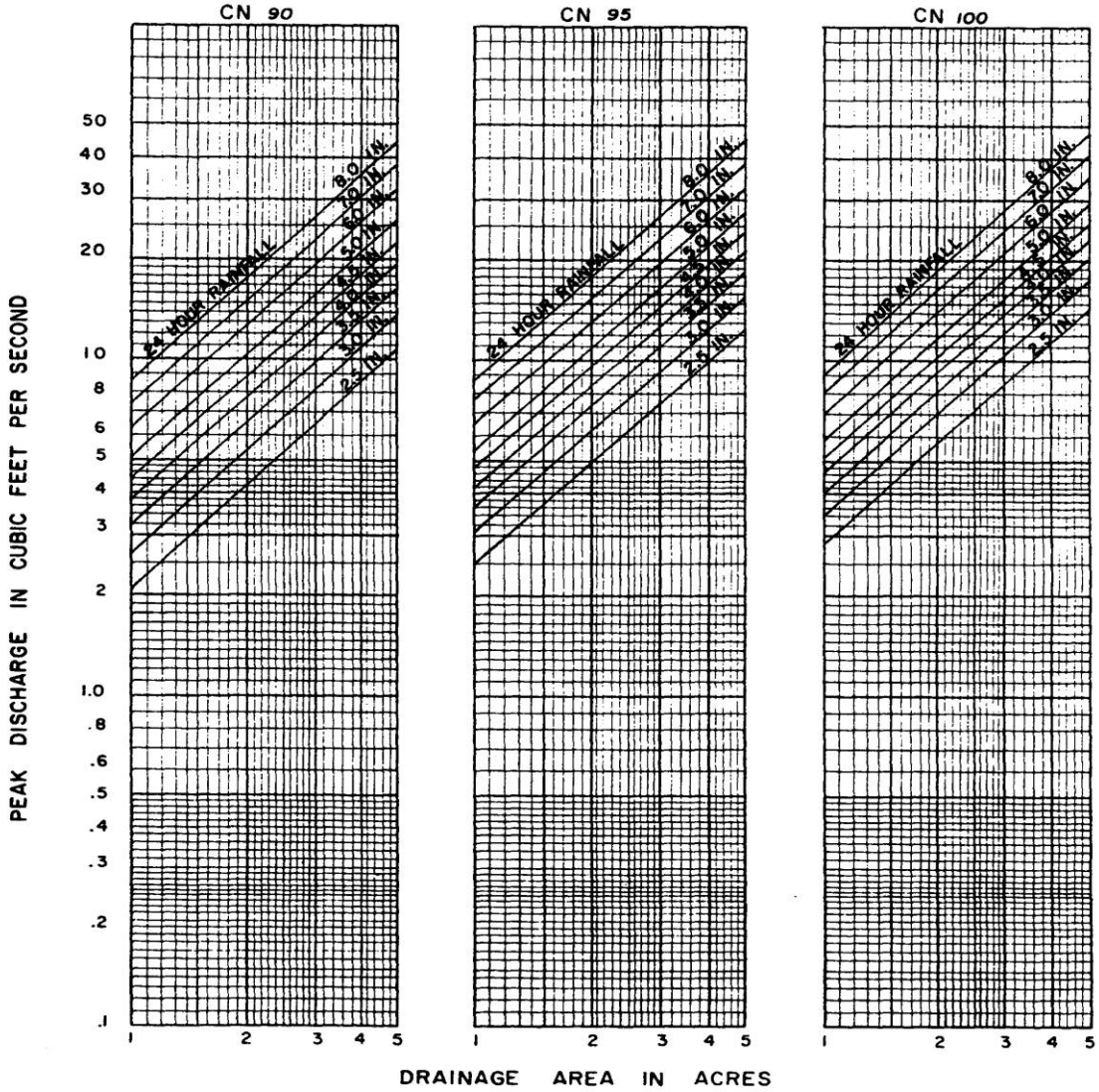

EXHIBIT 2-4A

PEAK RATES OF DISCHARGE FOR WATERSHEDS OF 1 TO 5 ACRES  
TYPE II STORM DISTRIBUTION

SLOPES STEEP

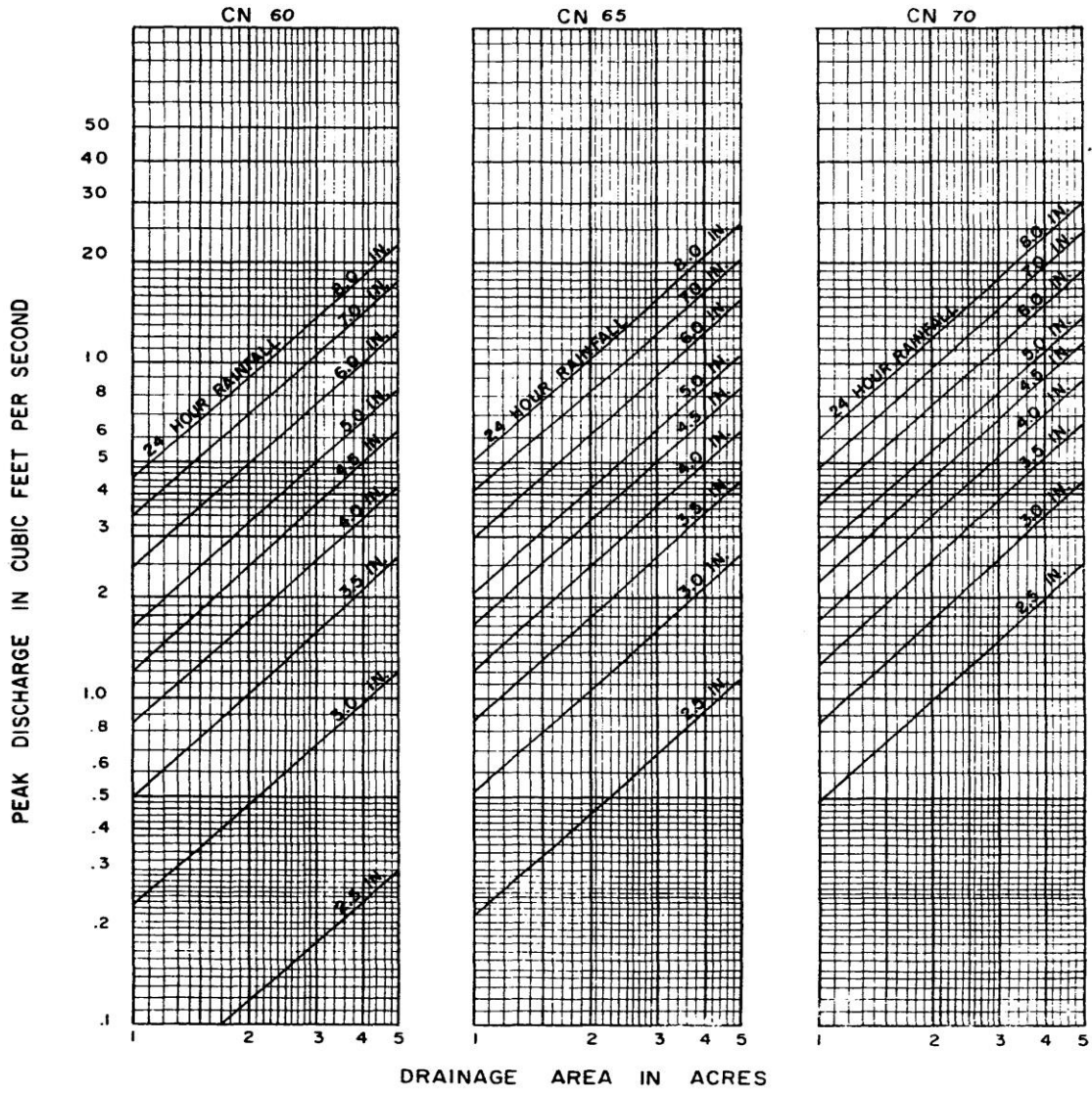

EXHIBIT 2-4A

PEAK RATES OF DISCHARGE FOR WATERSHEDS OF 1 TO 5 ACRES  
TYPE II STORM DISTRIBUTION  
SLOPES STEEP

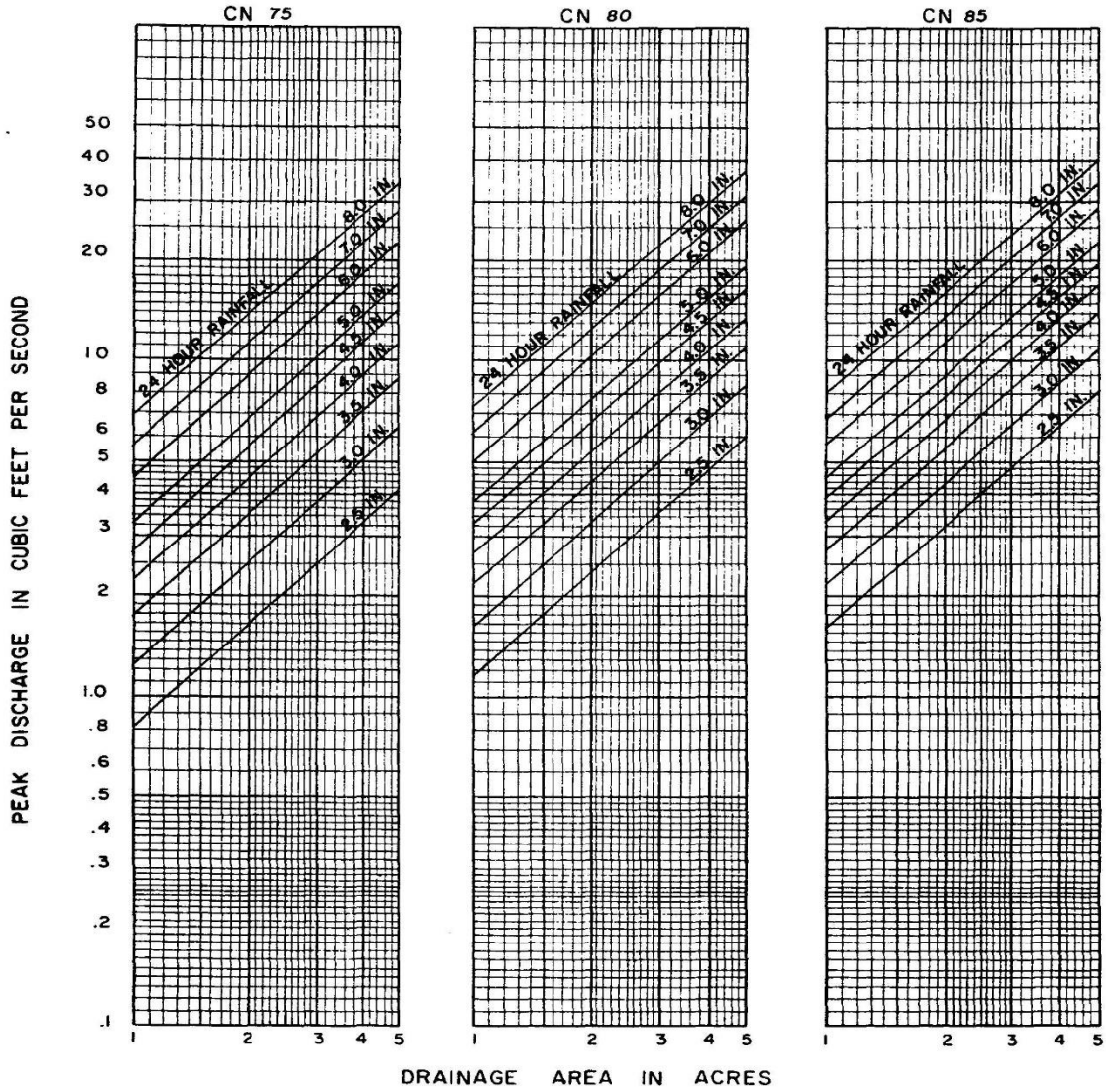

EXHIBIT 2-4A

PEAK RATES OF DISCHARGE FOR WATERSHEDS OF 1 TO 5 ACRES  
TYPE II STORM DISTRIBUTION  
SLOPES STEEP

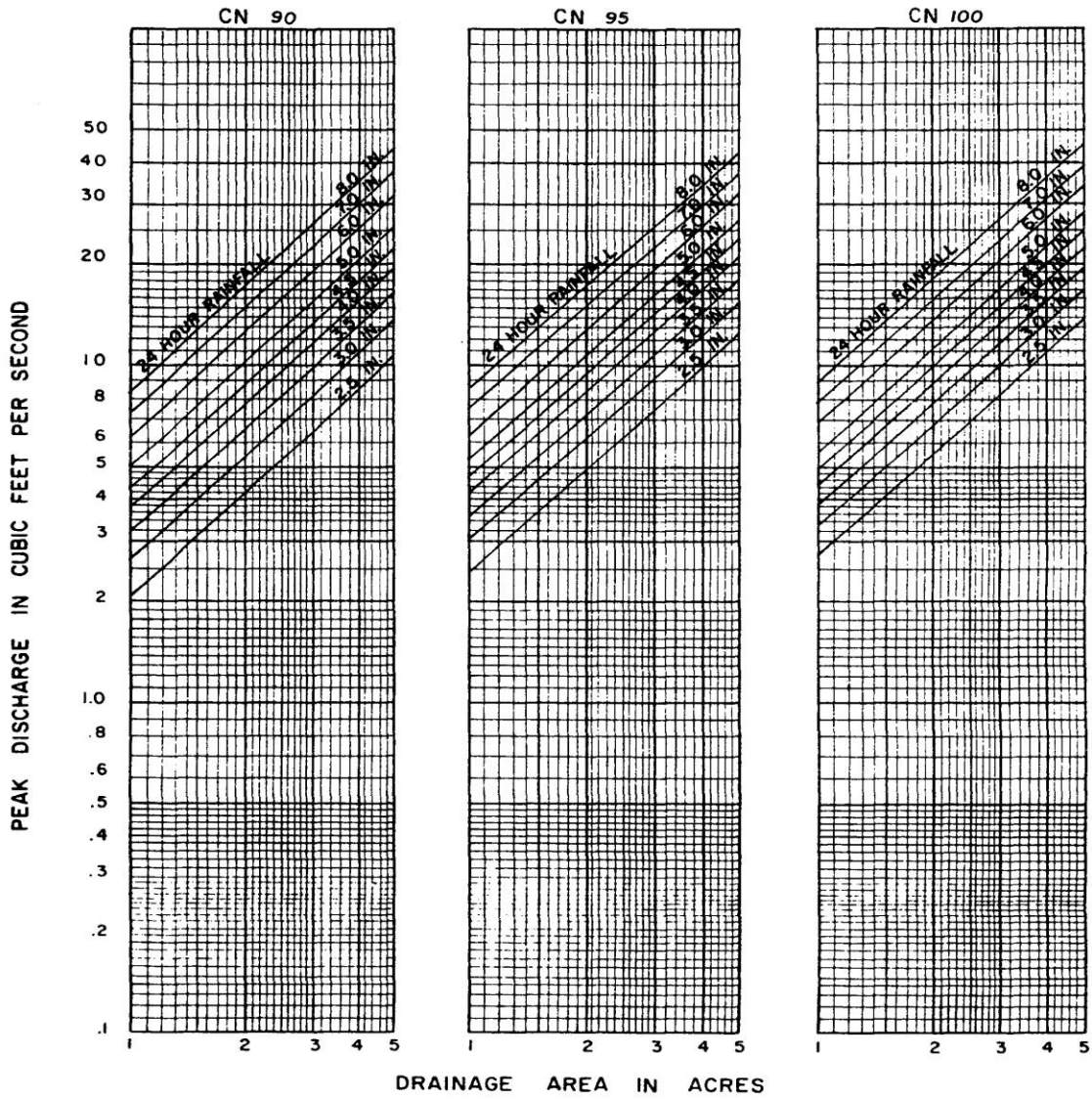

EXHIBIT 2-4A

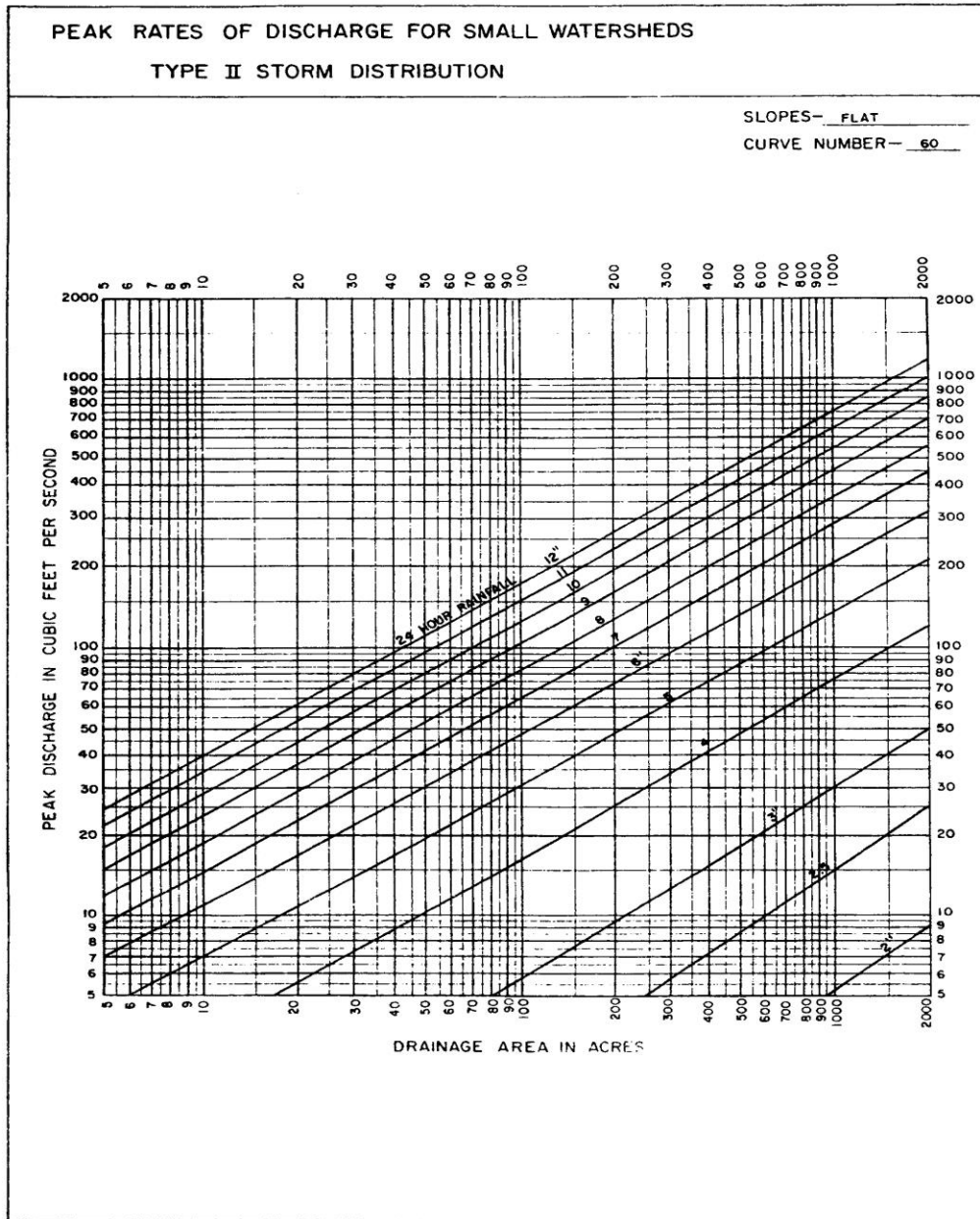

EXHIBIT 2-4

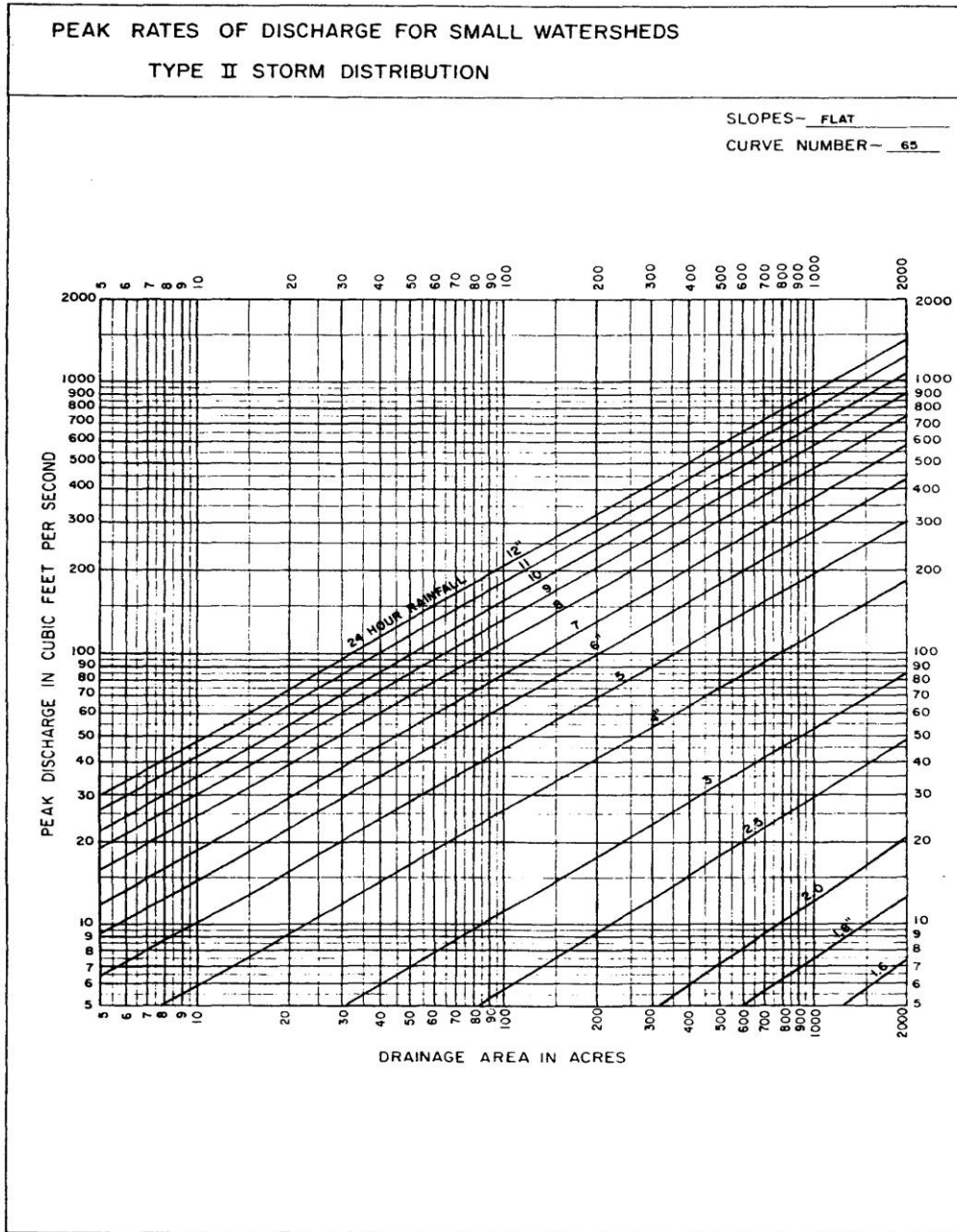

EXHIBIT 2-4

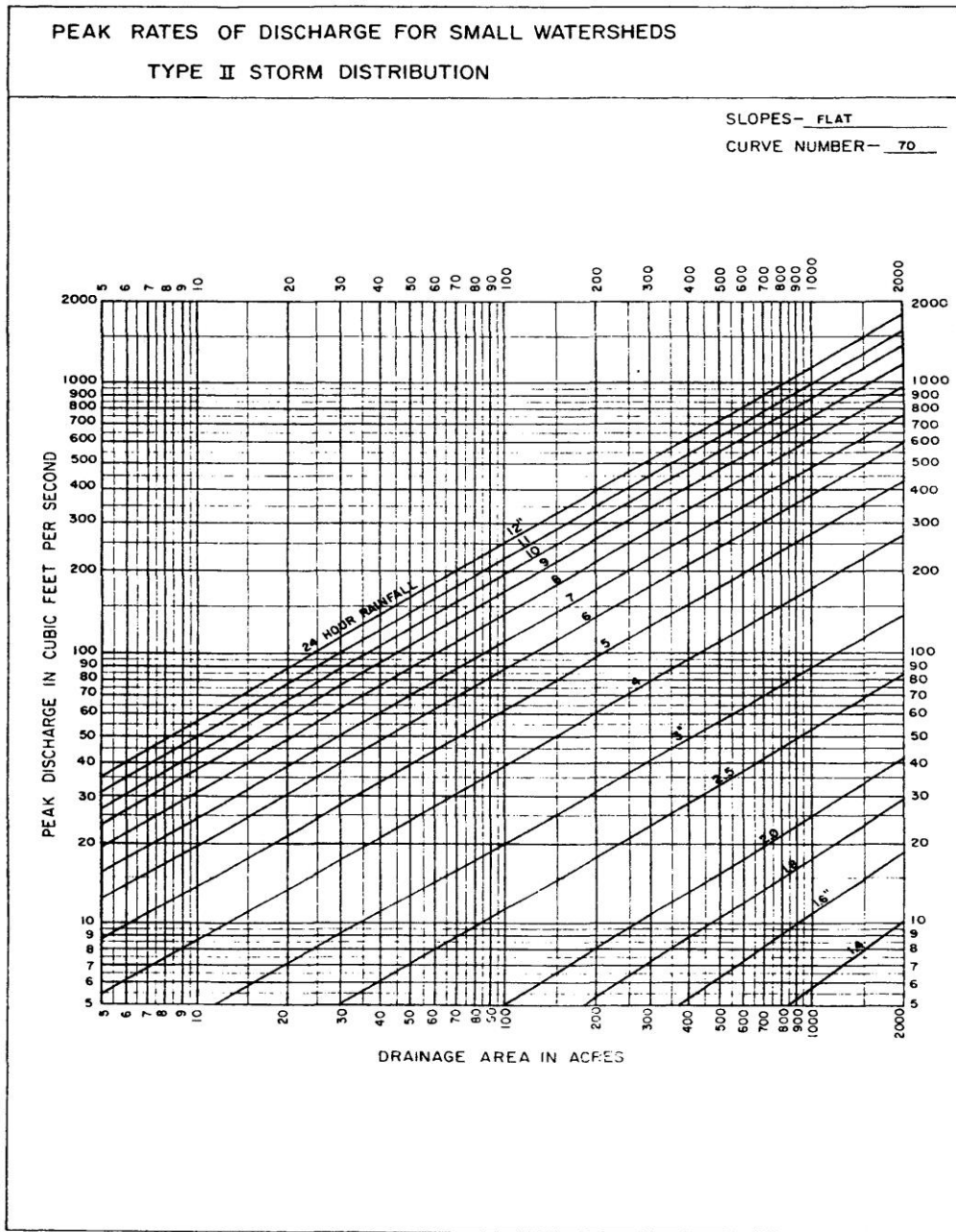

EXHIBIT 2 - 4

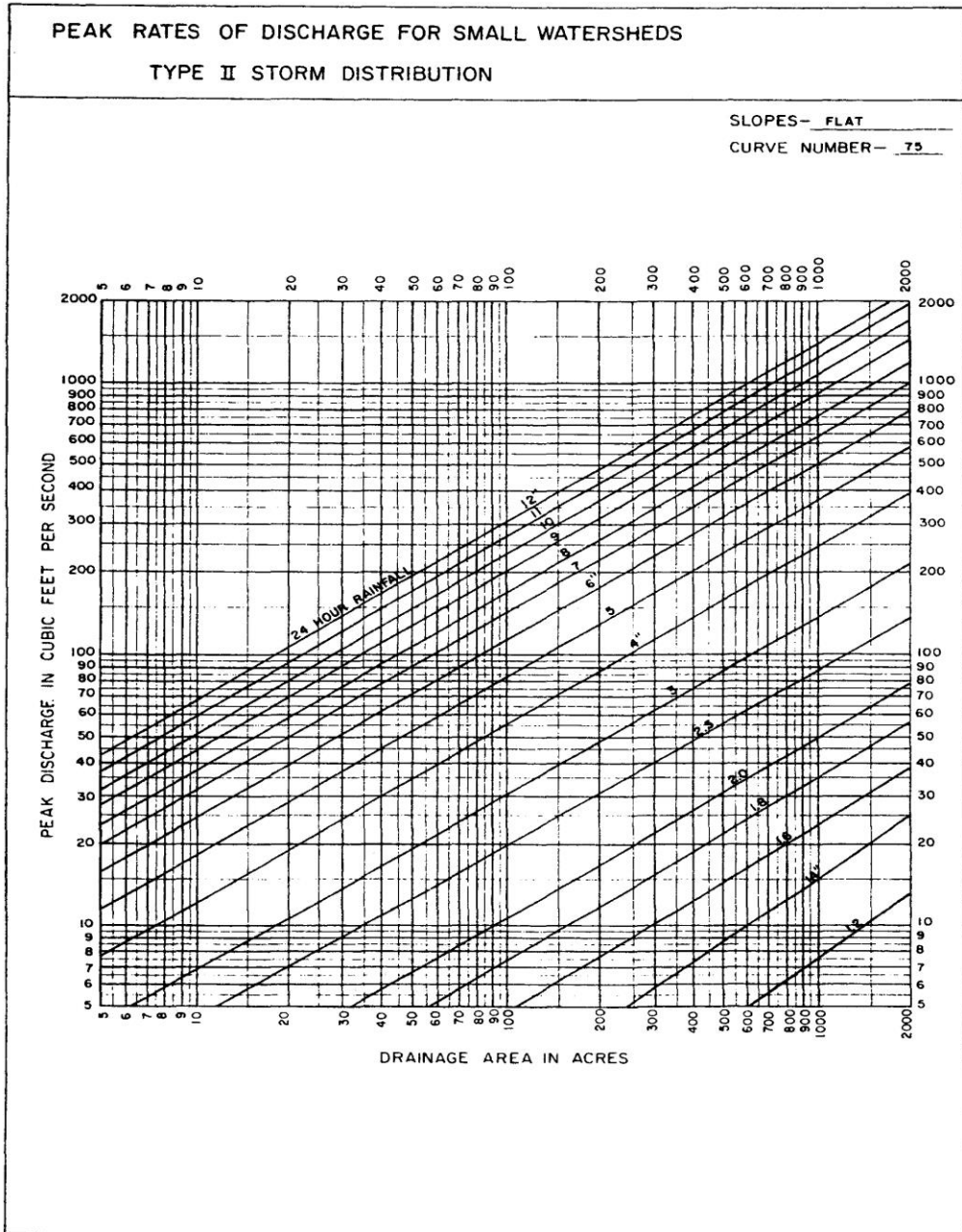

EXHIBIT 2-4

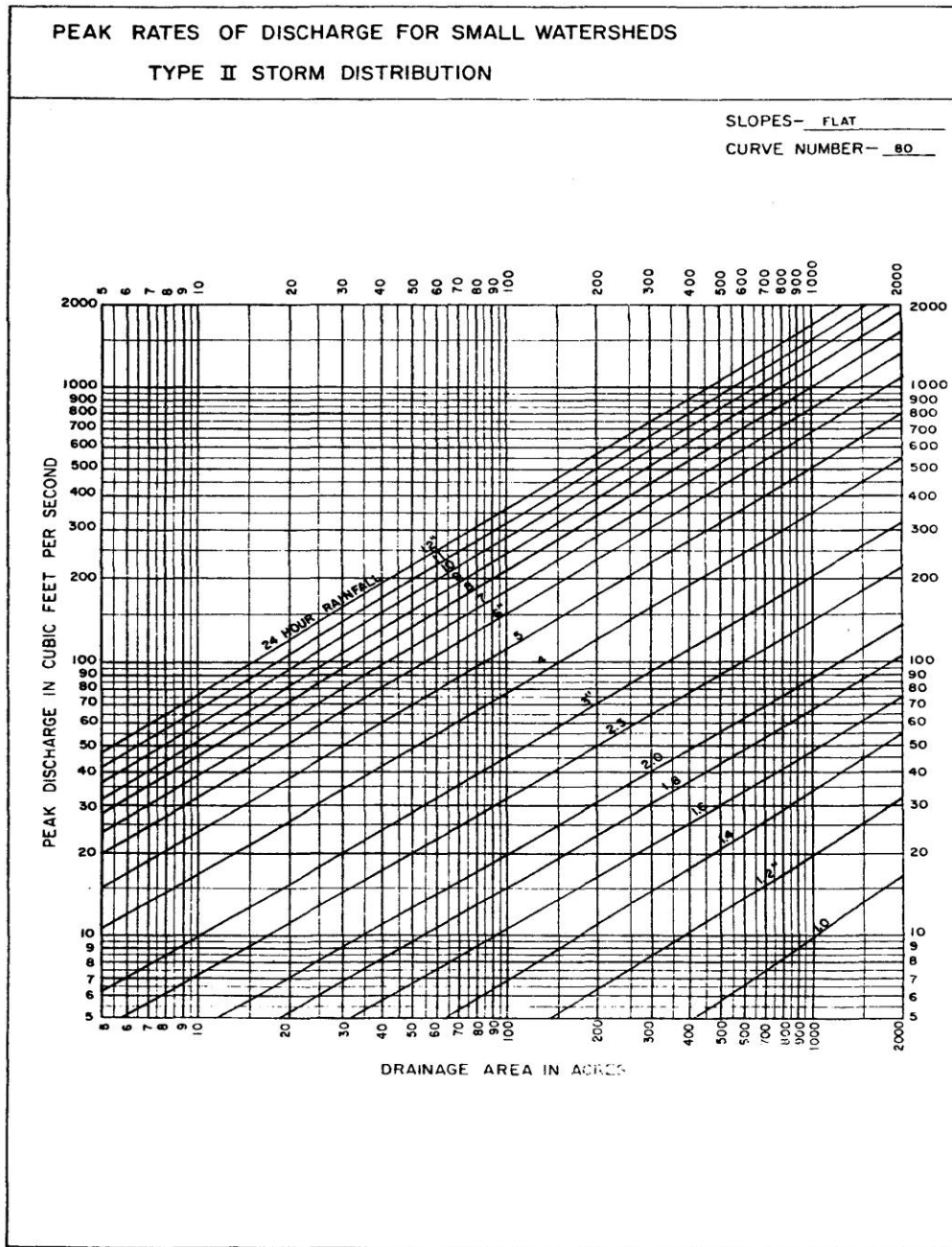

EXHIBIT 2 - 4

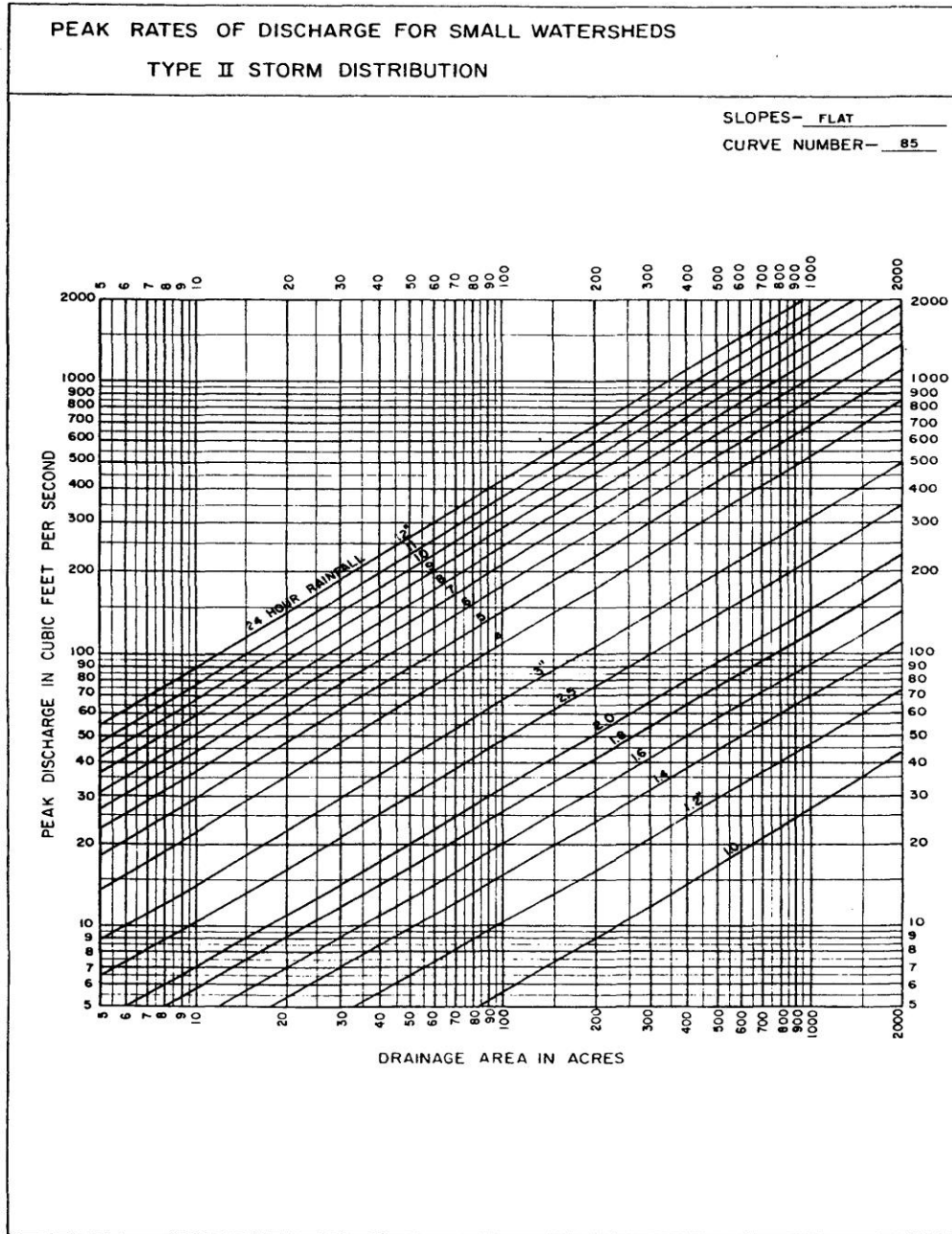

EXHIBIT 2-4

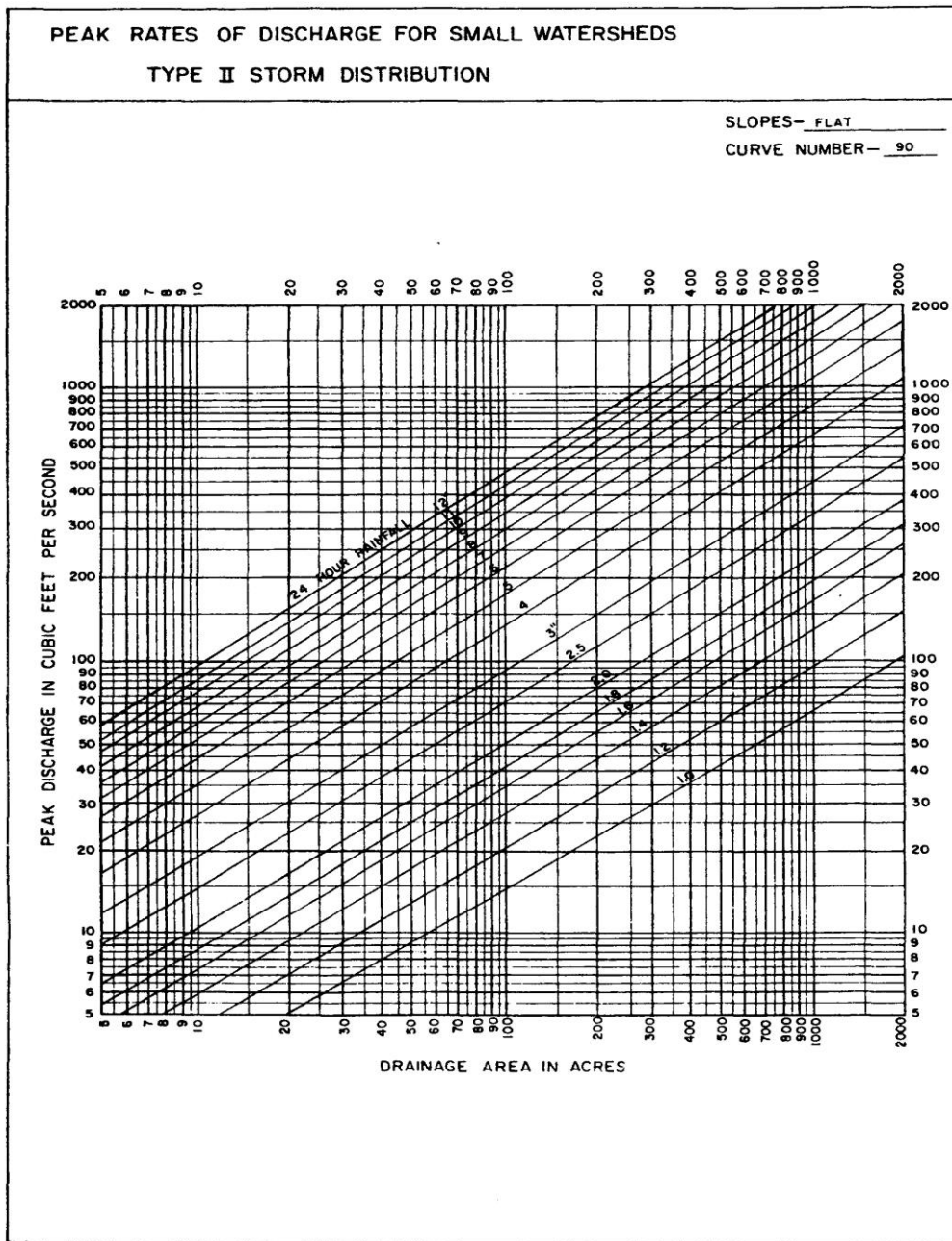

EXHIBIT 2-4

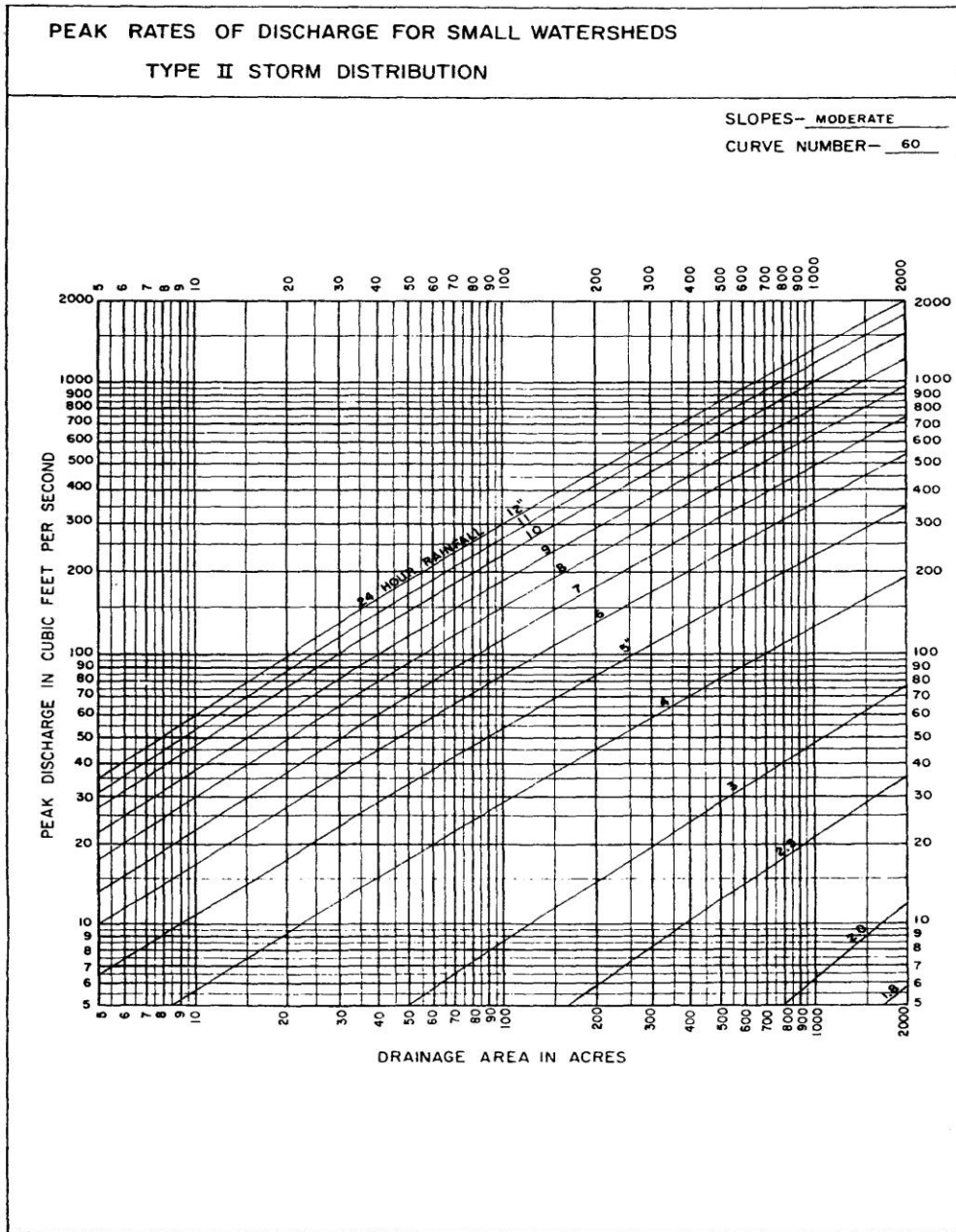

EXHIBIT 2-4

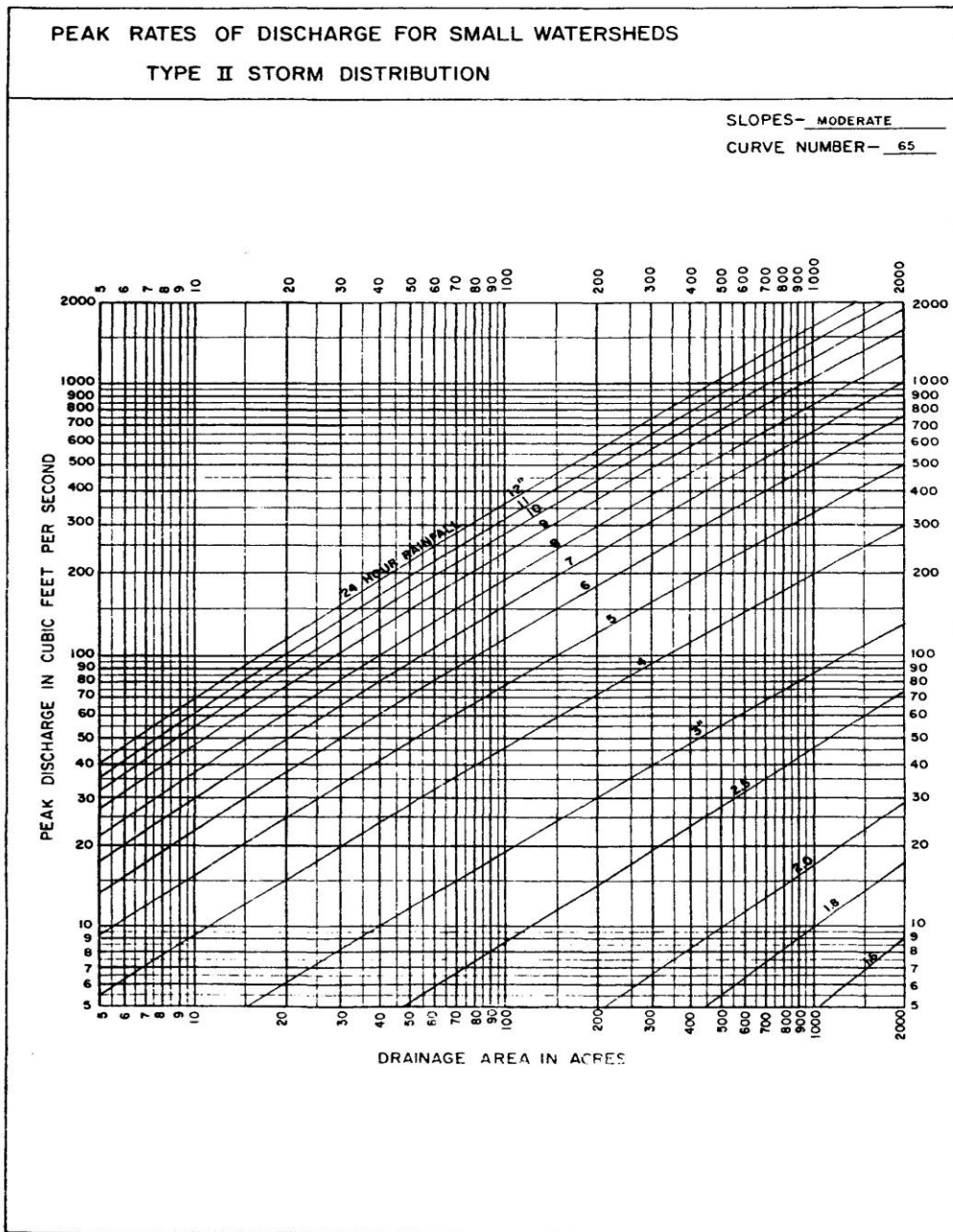

EXHIBIT 2-4

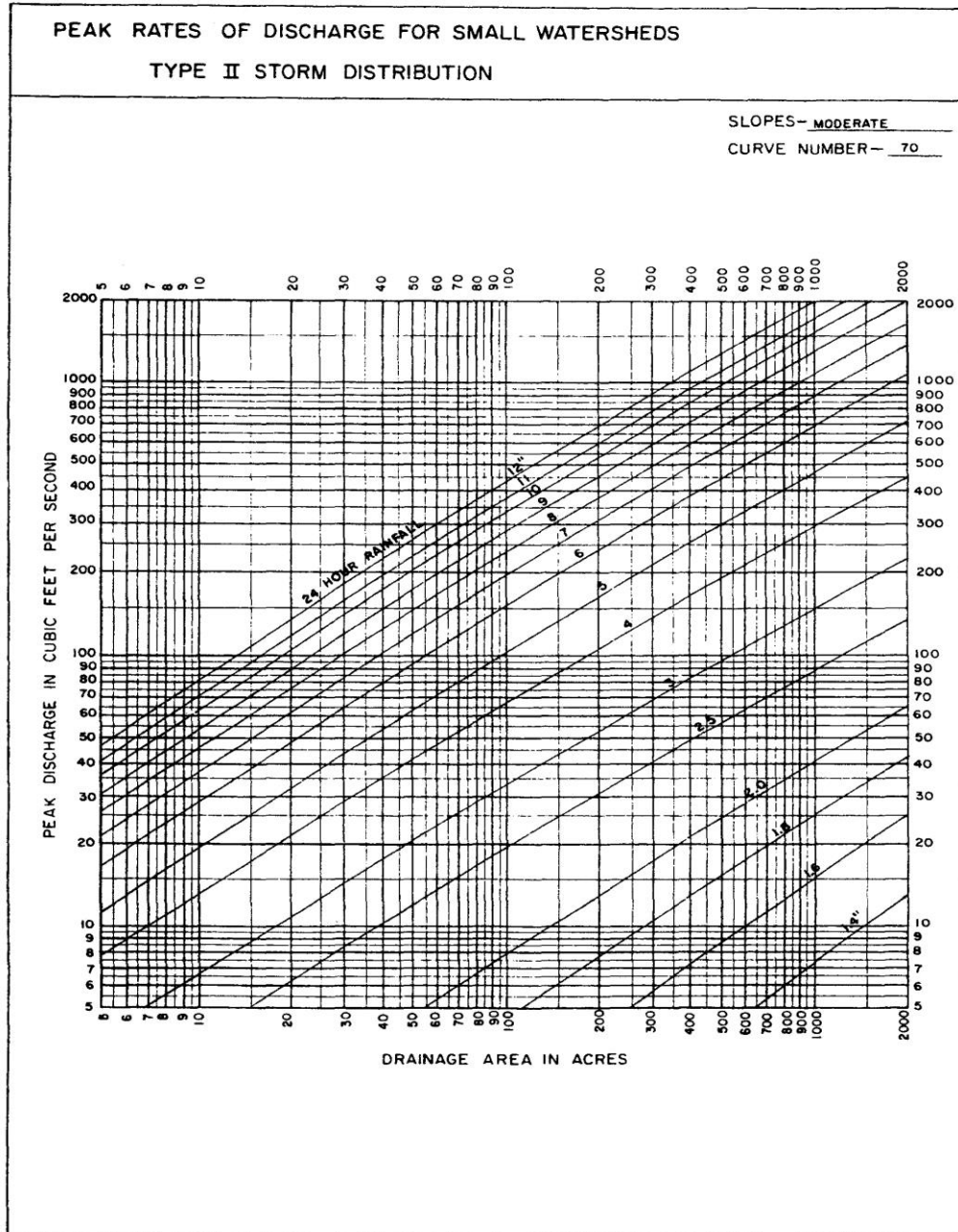

EXHIBIT 2-4

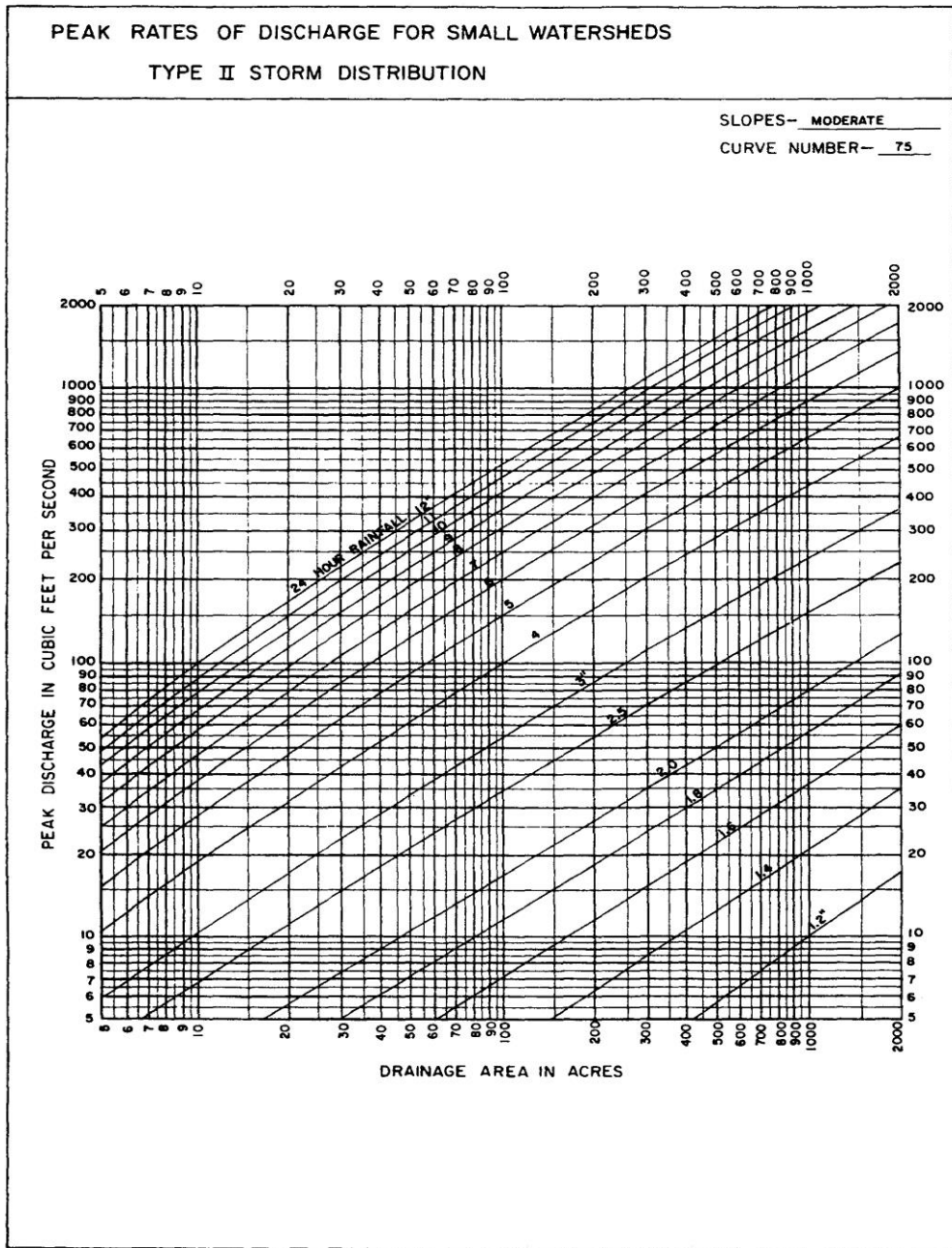

EXHIBIT 2-4

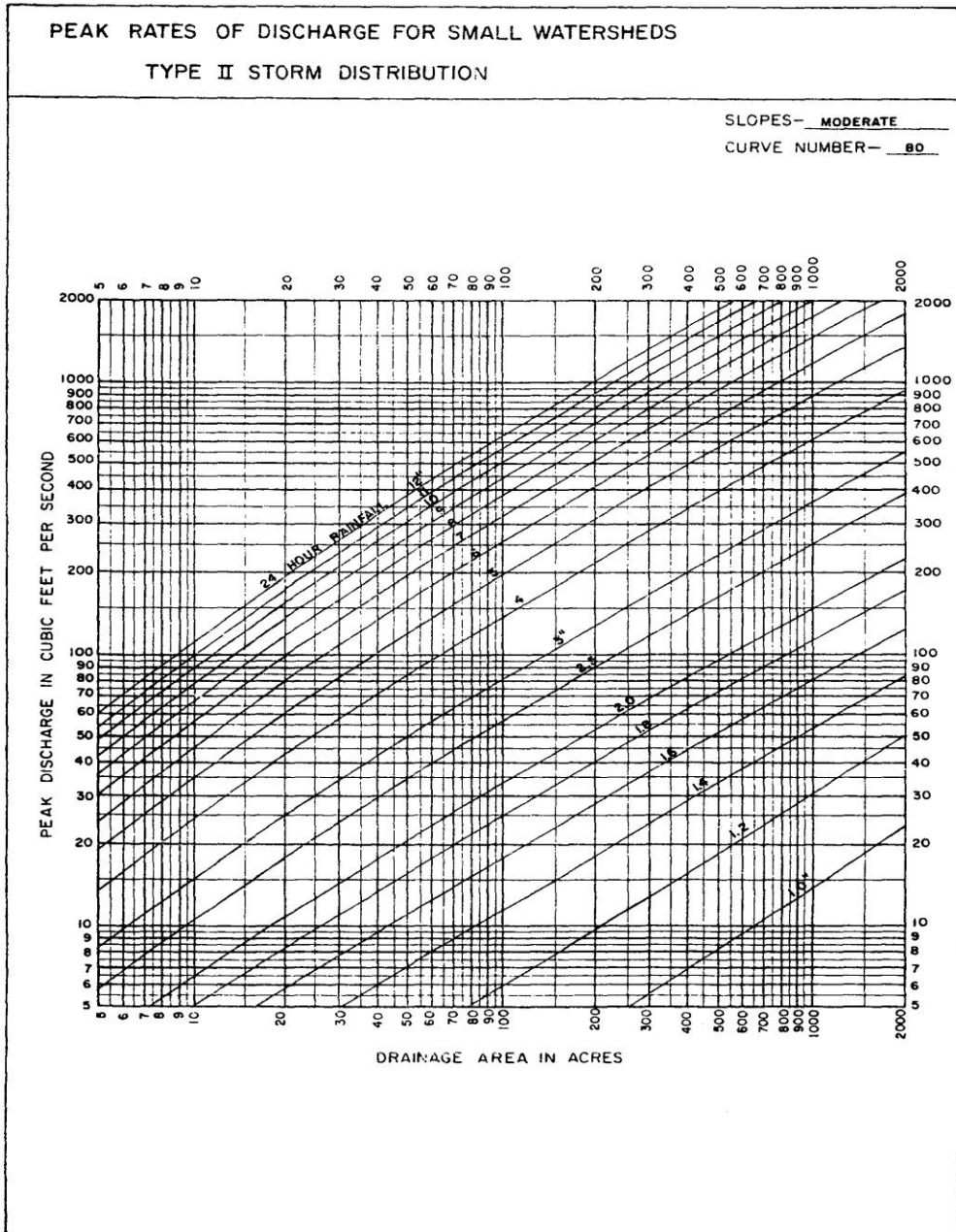

EXHIBIT 2-4

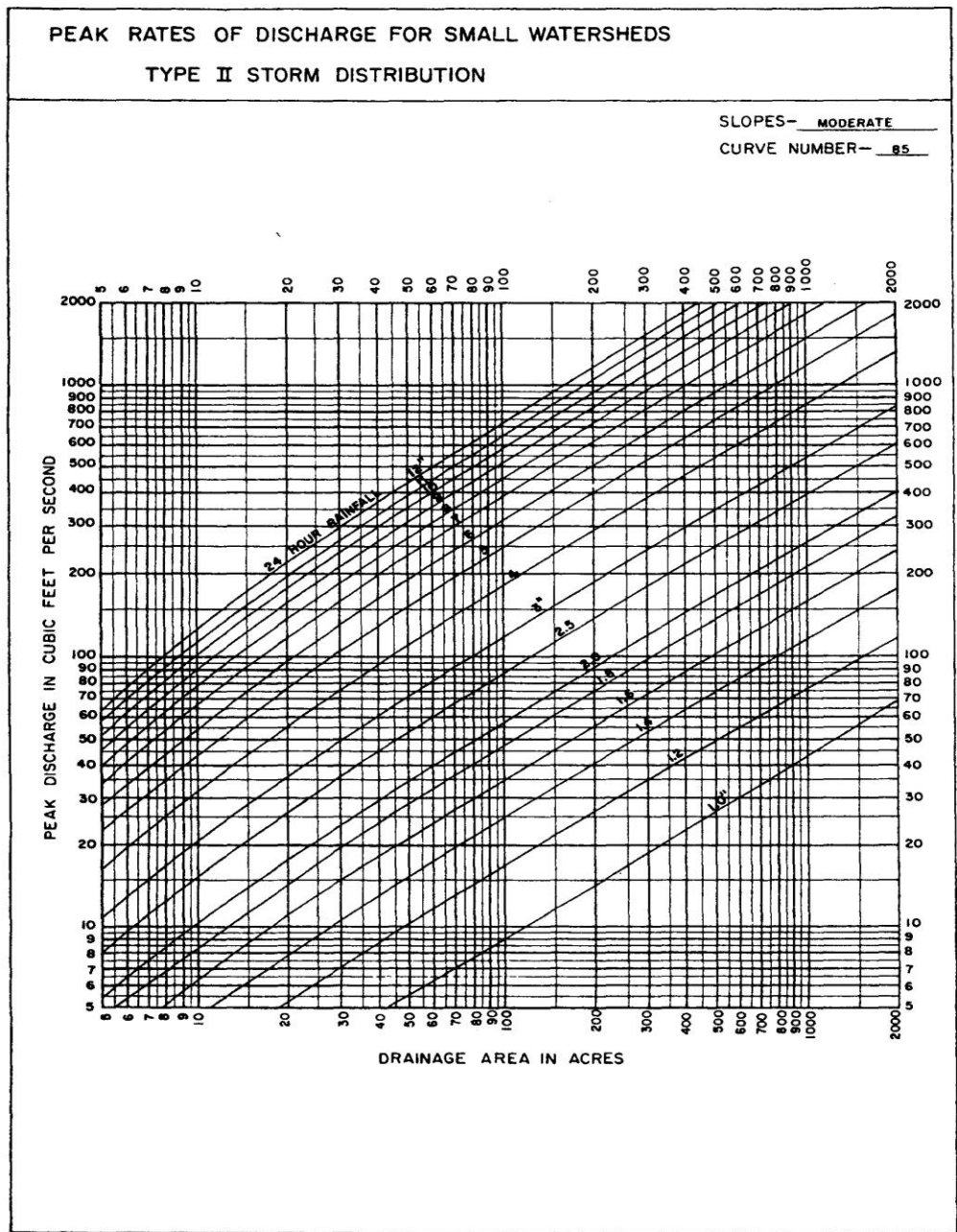

EXHIBIT 2-4

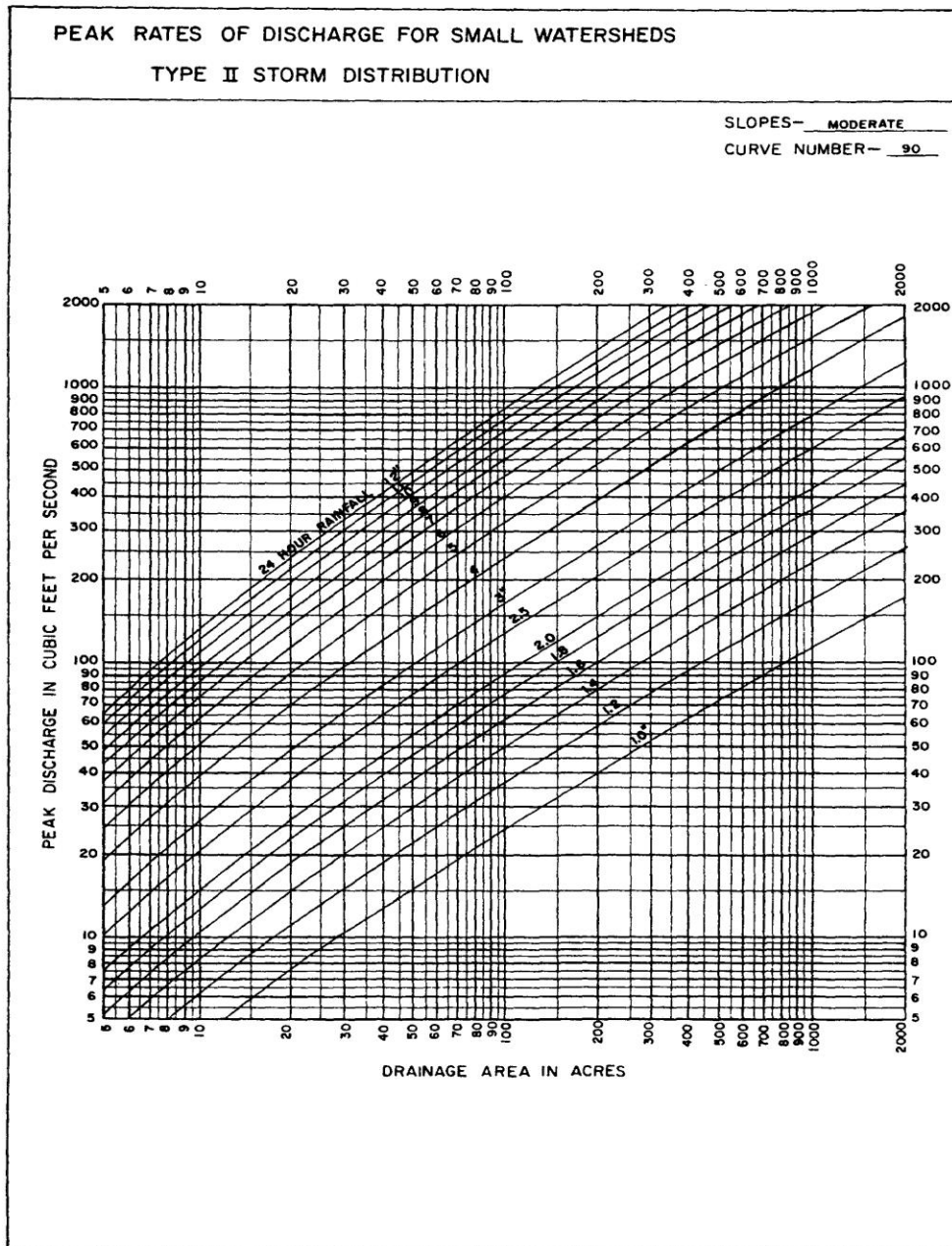

EXHIBIT 2-4

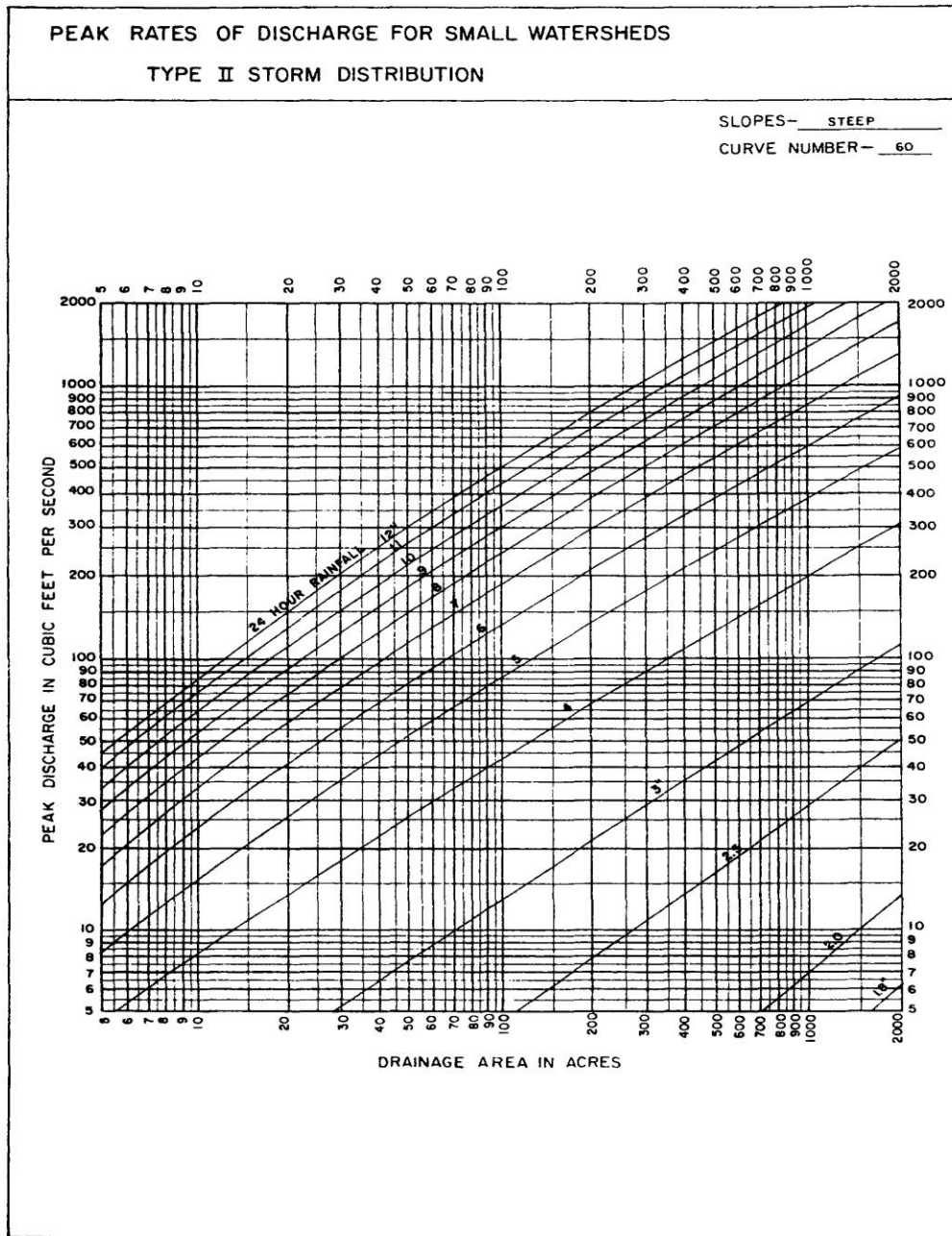

EXHIBIT 2-4

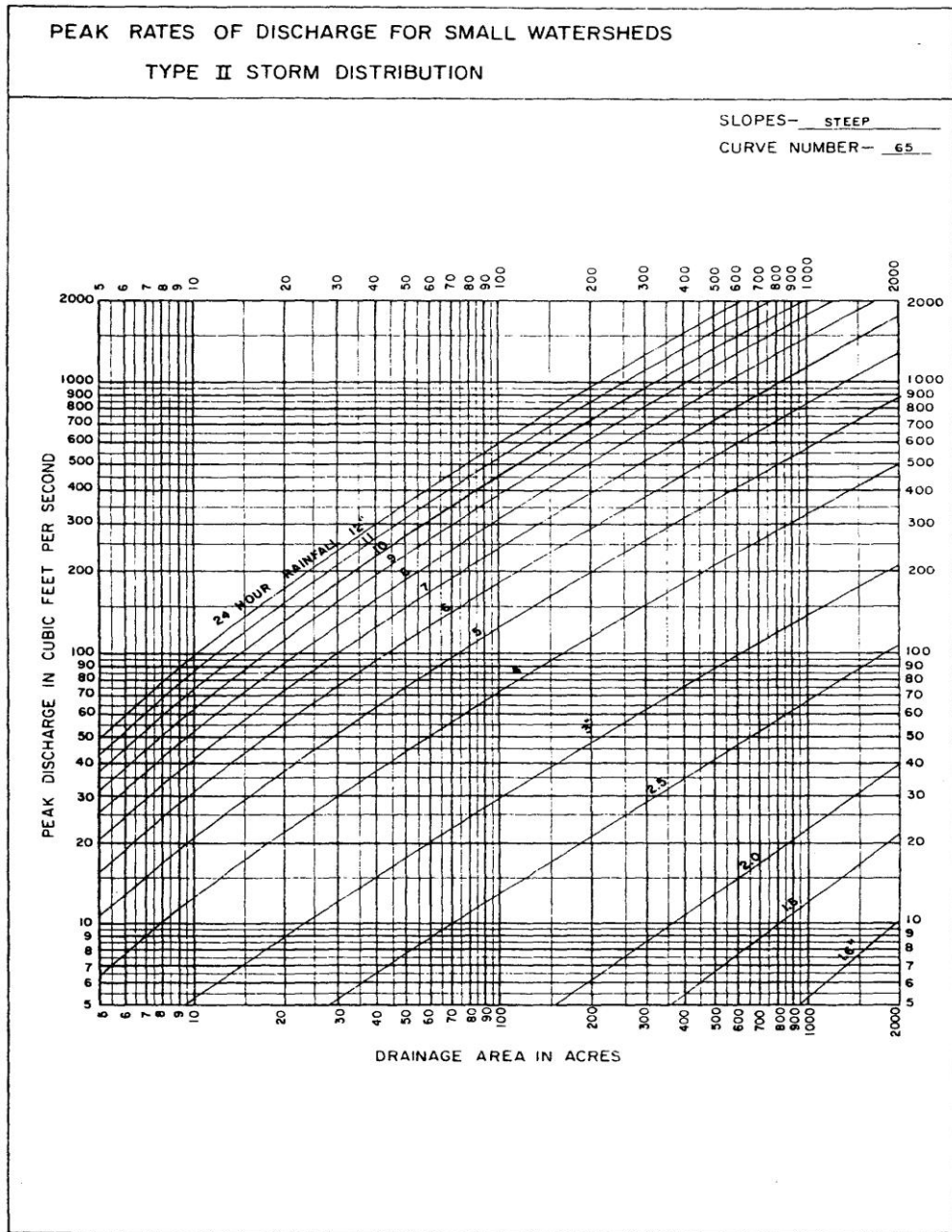

EXHIBIT 2-4

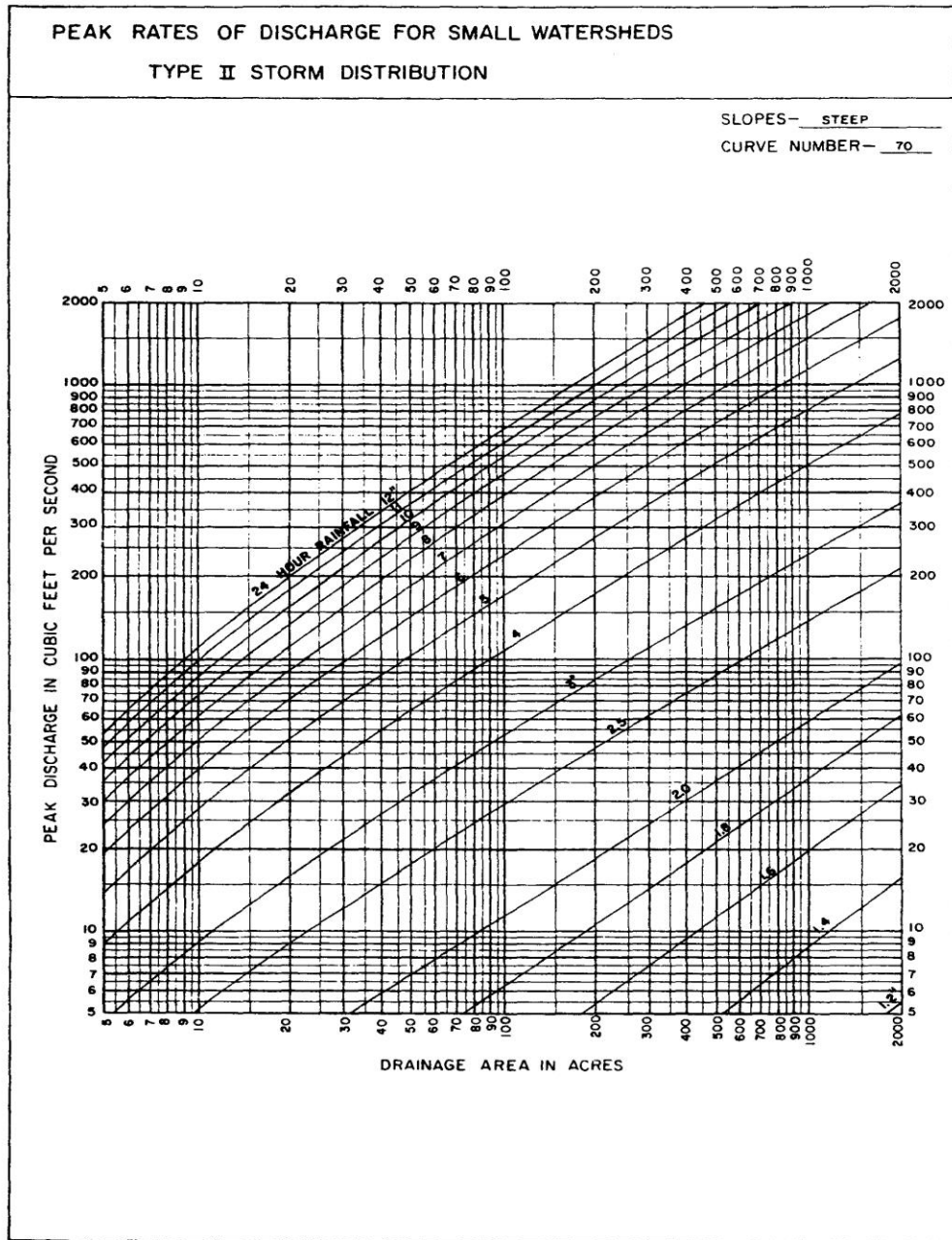

EXHIBIT 2-4

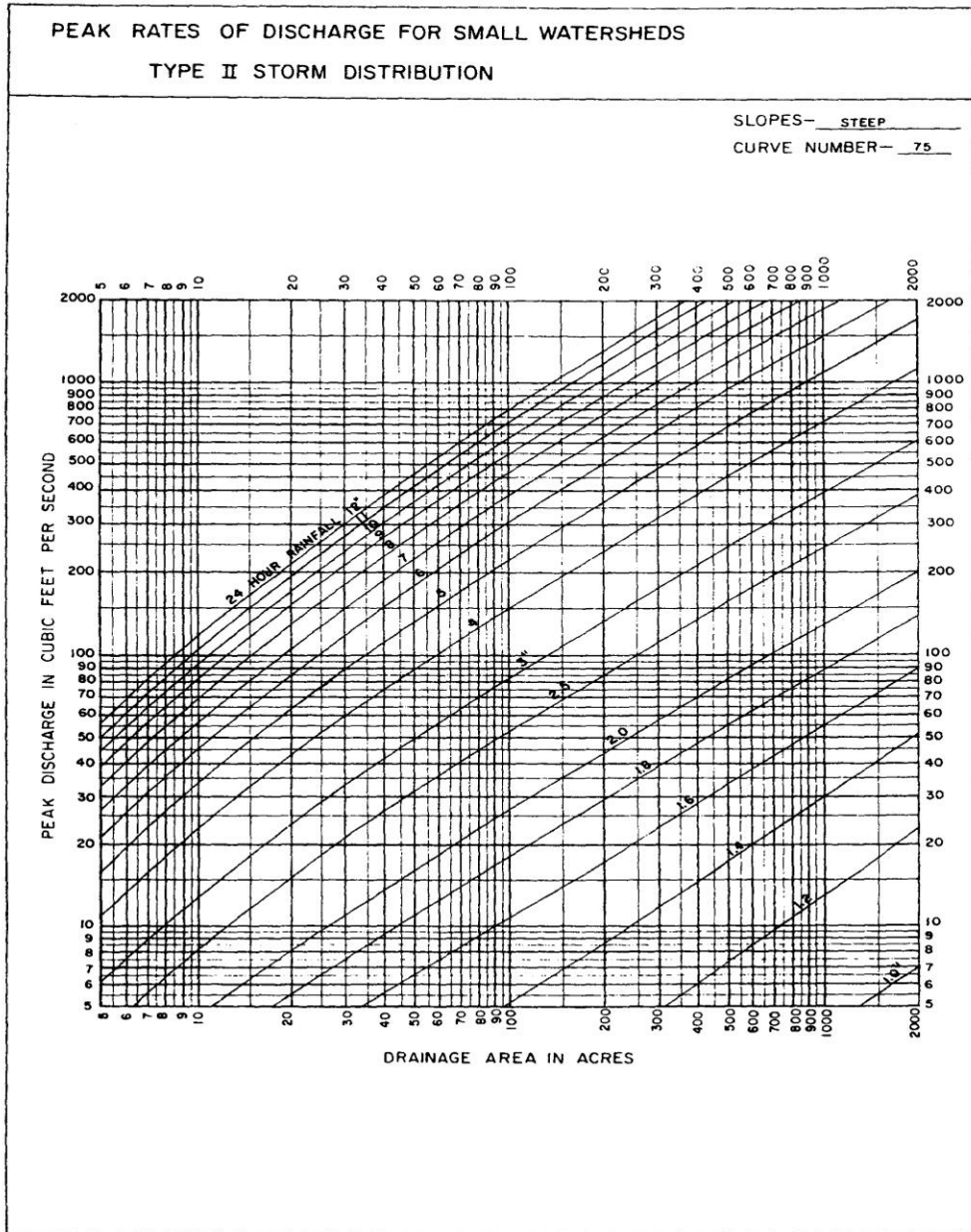

EXHIBIT 2-4

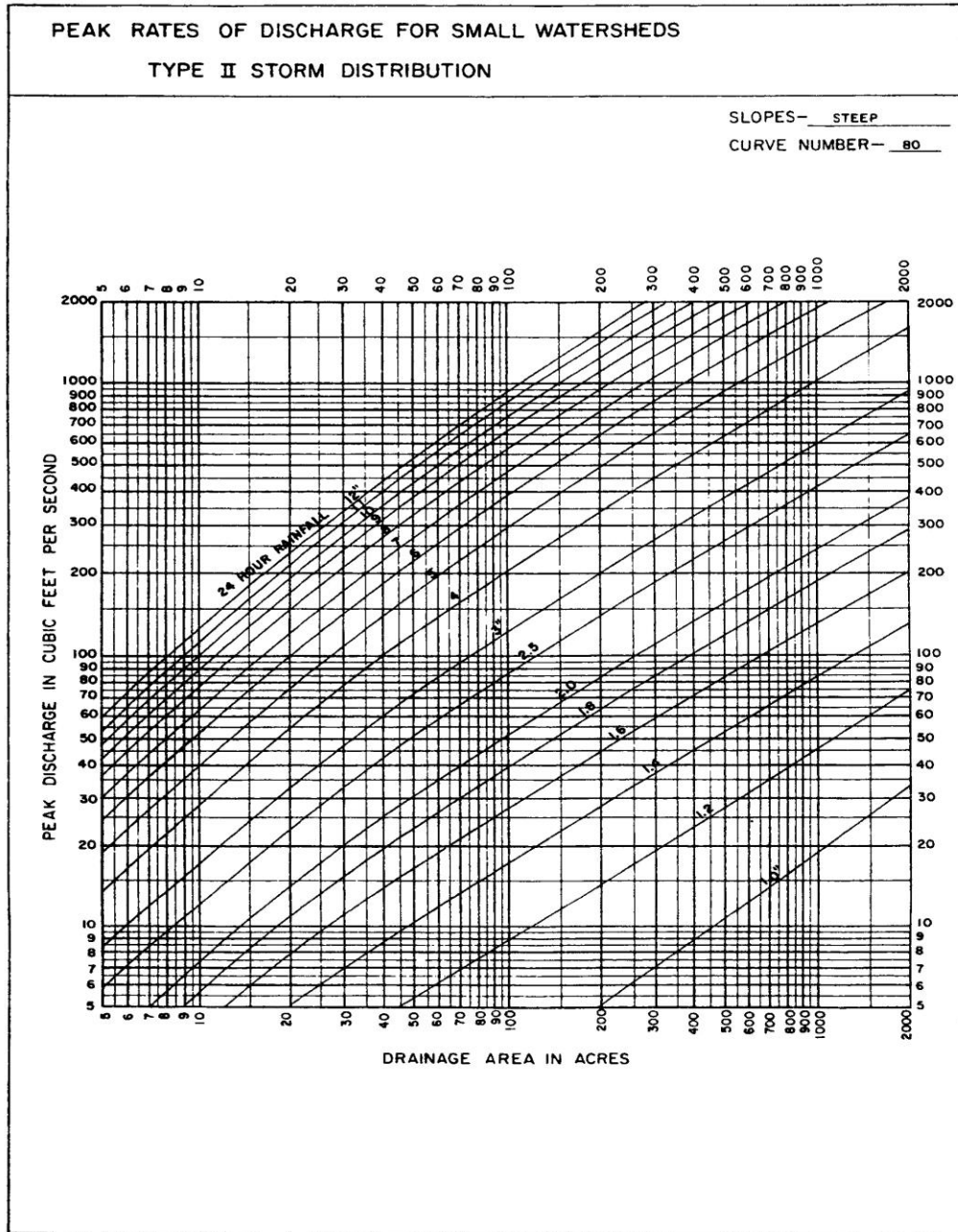

EXHIBIT 2-4

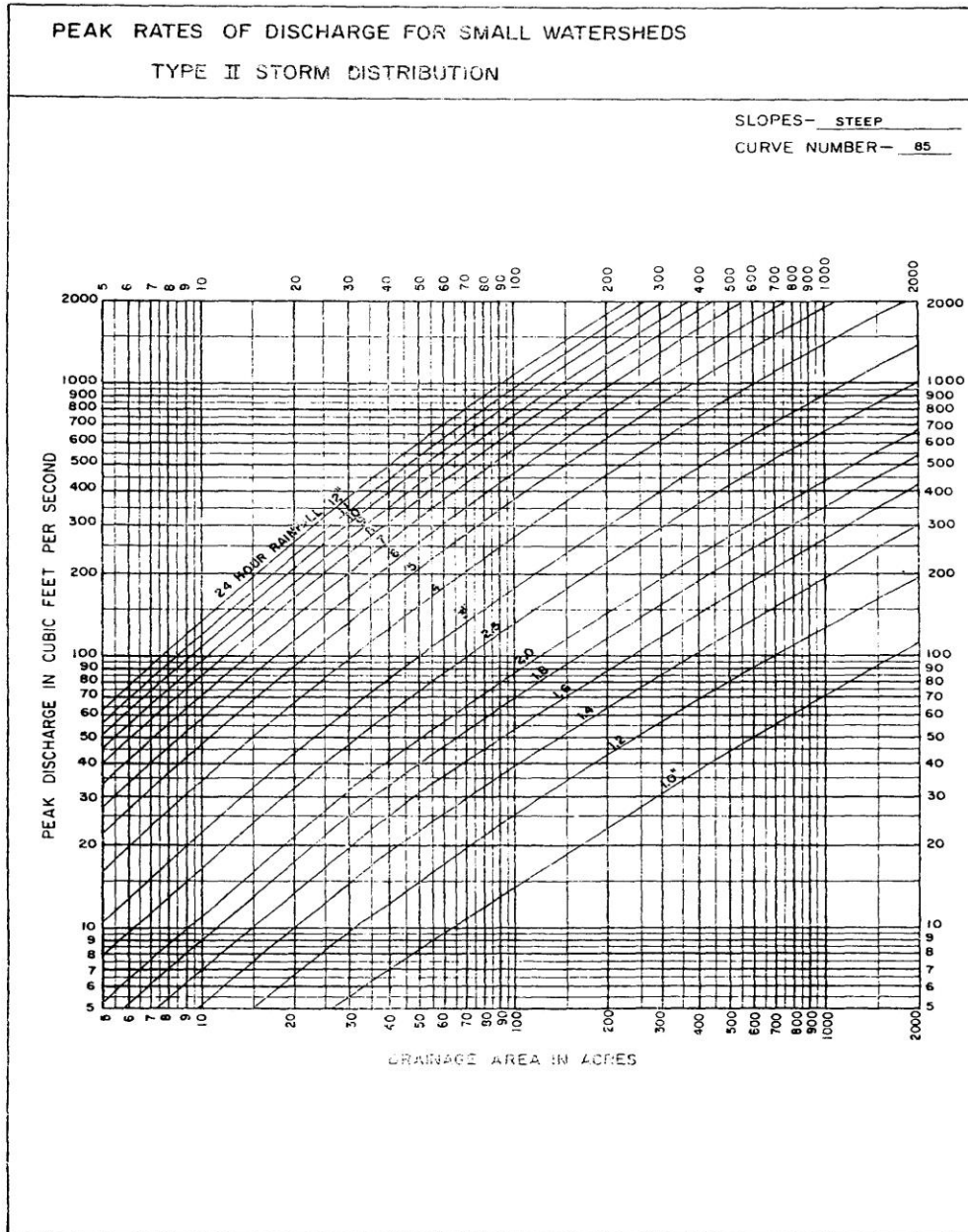

EXHIBIT 2-4

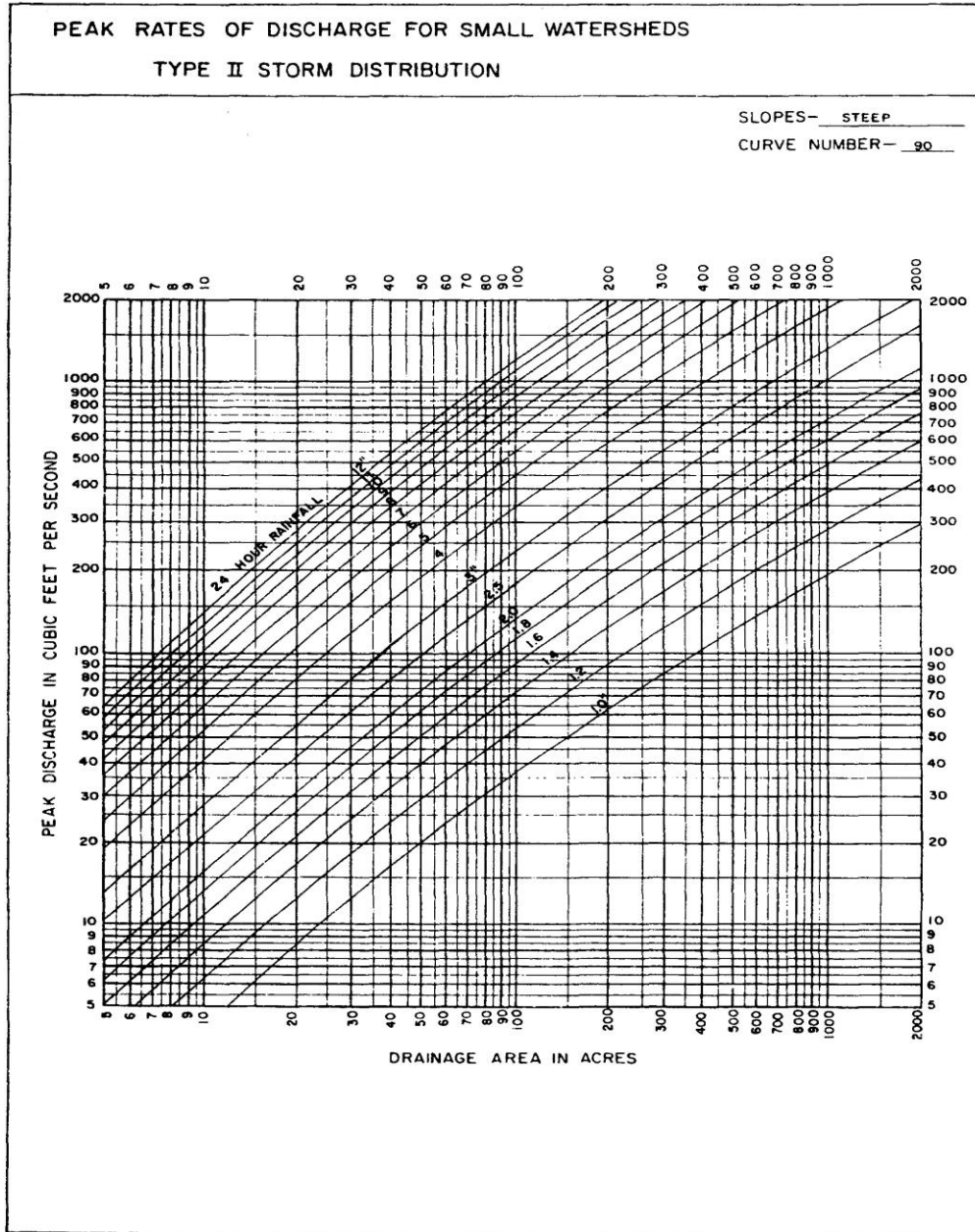

EXHIBIT 2-4

EXHIBIT 2-5  
INTERPOLATING FACTORS  
FOR VARIOUS SLOPES AND DRAINAGE AREAS

(Use discharge values from Exhibit 2-4 & 2-4A sheets labeled "Flat")

Slope %	Acres	
	1-50	51-500
.1	.47	.43
.2	.58	.55
.3	.66	.64
.4	.74	.71
.5	.79	.77
.7	.89	.88
1.0	1.00	1.00
2.0	1.13	1.16

(Use discharge values from Exhibit 2-4 & 2-4A sheets labeled "Moderate")

Slope %	Acres	
	1-50	51-500
3	.96	.95
4	1.00	1.00
5	1.04	1.05
6	1.07	1.10
7	1.09	1.13

Steep Slopes - round to nearest % slope shown

(Use discharge values from Exhibit 2-4 & 2-4A sheets labeled "Steep")

Slope %	Acres	
	1-50	51-500
8	.92	.88
9	.93	.90
10	.94	.91
11	.95	.93
12	.96	.94
13	.97	.96
14	.98	.97
15	.99	.99
16	1.00	1.00
17	1.01	1.02
18	1.02	1.03
19	1.03	1.05
20	1.04	1.08
25	1.08	1.14
30	1.11	1.20
35	1.13	1.24
40	1.16	1.29
45	1.18	1.31
50	1.21	1.34
55	1.23	1.35
60	1.26	1.37
65	1.28	1.39
70	1.30	1.40
75	1.32	1.42

EXHIBIT 2-6

# RUNOFF FOR INCHES OF RAINFALL.

(Curve No. 55)

Inches/Tenths	0.0	0.1	0.2	0.3	0.4	0.5	0.6	0.7	0.8	0.9
0										
1	0.00	0.00	0.00	0.00	0.00	0.00	0.00	0.00	0.00	0.01
2	0.02	0.03	0.04	0.05	0.06	0.08	0.10	0.12	0.14	0.16
3	0.19	0.22	0.25	0.28	0.31	0.34	0.37	0.41	0.45	0.49
4	0.53	0.57	0.61	0.65	0.69	0.73	0.78	0.83	0.88	0.93
5	0.98	1.03	1.08	1.13	1.18	1.23	1.28	1.34	1.40	1.46
6	1.52	1.58	1.63	1.69	1.75	1.81	1.87	1.93	1.99	2.06
7	2.12	2.18	2.24	2.31	2.38	2.44	2.51	2.58	2.64	2.71
8	2.78	2.85	2.92	2.99	3.06	3.13	3.20	3.27	3.34	3.41
9	3.48	3.56	3.63	3.70	3.78	3.85	3.92	3.99	4.07	4.15
10	4.22	4.30	4.38	4.45	4.53	4.61	4.69	4.76	4.84	4.91

(Curve No. 56)

Inches/Tenths	0.0	0.1	0.2	0.3	0.4	0.5	0.6	0.7	0.8	0.9
0										
1	0.00	0.00	0.00	0.00	0.00	0.00	0.00	0.00	0.01	0.01
2	0.02	0.03	0.04	0.06	0.08	0.10	0.12	0.14	0.16	0.19
3	0.22	0.25	0.28	0.31	0.34	0.38	0.42	0.45	0.49	0.53
4	0.57	0.61	0.65	0.70	0.75	0.80	0.84	0.89	0.94	0.99
5	1.04	1.09	1.14	1.19	1.25	1.31	1.37	1.42	1.48	1.54
6	1.60	1.66	1.72	1.78	1.84	1.90	1.96	2.02	2.08	2.15
7	2.22	2.28	2.35	2.42	2.48	2.55	2.62	2.69	2.76	2.83
8	2.90	2.97	3.04	3.11	3.18	3.25	3.32	3.39	3.46	3.53
9	3.60	3.68	3.76	3.83	3.91	3.99	4.06	4.13	4.20	4.28
10	4.36	4.44	4.52	4.59	4.67	4.75	4.83	4.91	4.98	5.06

(Curve No. 57)

Inches/Tenths	0.0	0.1	0.2	0.3	0.4	0.5	0.6	0.7	0.8	0.9
0										
1	0.00	0.00	0.00	0.00	0.00	0.00	0.00	0.00	0.01	0.02
2	0.03	0.04	0.05	0.07	0.09	0.11	0.13	0.16	0.19	0.22
3	0.25	0.28	0.31	0.34	0.37	0.41	0.45	0.49	0.53	0.58
4	0.62	0.66	0.70	0.75	0.80	0.85	0.90	0.95	1.00	1.05
5	1.10	1.15	1.21	1.27	1.32	1.37	1.43	1.49	1.55	1.61
6	1.67	1.73	1.80	1.86	1.92	1.99	2.05	2.12	2.18	2.25
7	2.31	2.38	2.45	2.51	2.58	2.65	2.72	2.79	2.86	2.93
8	3.00	3.07	3.14	3.22	3.29	3.36	3.44	3.51	3.58	3.66
9	3.73	3.81	3.88	3.96	4.03	4.11	4.18	4.26	4.34	4.42
10	4.50	4.57	4.65	4.73	4.81	4.89	4.97	5.05	5.13	5.21

(Curve No. 58)

Inches/Tenths	0.0	0.1	0.2	0.3	0.4	0.5	0.6	0.7	0.8	0.9
0										
1	0.00	0.00	0.00	0.00	0.00	0.00	0.00	0.01	0.02	0.03
2	0.04	0.05	0.07	0.09	0.11	0.13	0.15	0.18	0.21	0.24
3	0.27	0.30	0.34	0.38	0.41	0.45	0.49	0.53	0.57	0.61
4	0.66	0.71	0.76	0.80	0.85	0.90	0.95	1.00	1.05	1.11
5	1.17	1.22	1.27	1.33	1.39	1.45	1.51	1.57	1.63	1.69
6	1.76	1.82	1.88	1.95	2.01	2.07	2.14	2.21	2.27	2.34
7	2.41	2.48	2.55	2.61	2.68	2.75	2.82	2.90	2.97	3.04
8	3.11	3.18	3.26	3.33	3.40	3.48	3.55	3.63	3.70	3.78
9	3.83	3.93	4.01	4.08	4.16	4.24	4.32	4.39	4.47	4.55
10	4.63	4.71	4.79	4.87	4.95	5.03	5.11	5.19	5.27	5.35

(Curve No. 59)

Inches/Tenths	0.0	0.1	0.2	0.3	0.4	0.5	0.6	0.7	0.8	0.9
0										
1	0.00	0.00	0.00	0.00	0.00	0.00	0.01	0.01	0.02	0.03
2	0.04	0.06	0.08	0.10	0.12	0.15	0.18	0.21	0.24	0.27
3	0.30	0.33	0.37	0.41	0.45	0.49	0.53	0.57	0.62	0.67
4	0.71	0.76	0.81	0.86	0.91	0.96	1.01	1.07	1.12	1.18
5	1.23	1.29	1.35	1.41	1.47	1.53	1.59	1.65	1.71	1.77
6	1.83	1.90	1.97	2.03	2.10	2.17	2.23	2.30	2.37	2.44
7	2.51	2.58	2.65	2.72	2.79	2.86	2.93	3.00	3.08	3.15
8	3.22	3.30	3.37	3.45	3.52	3.60	3.67	3.75	3.82	3.90
9	3.98	4.05	4.13	4.21	4.29	4.37	4.45	4.53	4.60	4.68
10	4.76	4.84	4.92	5.00	5.09	5.17	5.25	5.33	5.41	5.49

(Curve No. 60)

Inches/Tenths	0.0	0.1	0.2	0.3	0.4	0.5	0.6	0.7	0.8	0.9
0										
1	0.00	0.00	0.00	0.00	0.00	0.00	0.01	0.02	0.03	0.04
2	0.06	0.08	0.10	0.12	0.14	0.17	0.20	0.23	0.27	0.30
3	0.33	0.37	0.41	0.45	0.49	0.53	0.57	0.62	0.67	0.72
4	0.76	0.81	0.86	0.91	0.97	1.03	1.08	1.13	1.19	1.25
5	1.30	1.36	1.42	1.48	1.54	1.61	1.67	1.73	1.80	1.86
6	1.92	1.99	2.06	2.12	2.19	2.26	2.33	2.40	2.47	2.54
7	2.61	2.68	2.75	2.82	2.89	2.97	3.04	3.11	3.18	3.26
8	3.34	3.41	3.49	3.56	3.64	3.72	3.79	3.87	3.95	4.03
9	4.10	4.18	4.26	4.34	4.42	4.50	4.58	4.66	4.74	4.82
10	4.90	4.98	5.07	5.15	5.23	5.31	5.39	5.48	5.56	5.64

(Curve No. 61)

Inches/Tenths	0.0	0.1	0.2	0.3	0.4	0.5	0.6	0.7	0.8	0.9
0										
1						0.01	0.02	0.03	0.04	0.05
2	0.07	0.09	0.11	0.14	0.17	0.20	0.23	0.26	0.29	0.32
3	0.36	0.40	0.44	0.48	0.52	0.57	0.62	0.67	0.71	0.76
4	0.81	0.86	0.91	0.96	1.02	1.08	1.13	1.19	1.25	1.31
5	1.37	1.43	1.49	1.55	1.61	1.68	1.74	1.81	1.87	1.94
6	2.01	2.07	2.14	2.21	2.28	2.35	2.42	2.49	2.56	2.63
7	2.70	2.77	2.84	2.91	2.98	3.06	3.14	3.22	3.29	3.37
8	3.44	3.52	3.60	3.67	3.75	3.83	3.91	3.99	4.07	4.14
9	4.22	4.30	4.38	4.46	4.54	4.62	4.71	4.79	4.87	4.95
10	5.03	5.11	5.20	5.28	5.36	5.44	5.53	5.61	5.70	5.78

(Curve No. 62)

Inches/Tenths	0.0	0.1	0.2	0.3	0.4	0.5	0.6	0.7	0.8	0.9
0										
1						0.01	0.02	0.03	0.05	0.07
2	0.09	0.11	0.13	0.16	0.19	0.22	0.25	0.28	0.32	0.36
3	0.40	0.44	0.48	0.52	0.56	0.61	0.66	0.71	0.76	0.81
4	0.86	0.91	0.96	1.02	1.08	1.14	1.20	1.26	1.32	1.38
5	1.44	1.50	1.56	1.62	1.68	1.74	1.81	1.88	1.95	2.02
6	2.09	2.16	2.23	2.30	2.37	2.44	2.51	2.58	2.65	2.72
7	2.80	2.87	2.94	3.02	3.09	3.17	3.24	3.32	3.40	3.48
8	3.55	3.63	3.71	3.79	3.86	3.94	4.02	4.10	4.18	4.26
9	4.34	4.42	4.50	4.59	4.67	4.75	4.83	4.91	5.00	5.08
10	5.16	5.25	5.33	5.41	5.50	5.58	5.66	5.75	5.83	5.92

(Curve No. 63)

Inches/Tenths	0.0	0.1	0.2	0.3	0.4	0.5	0.6	0.7	0.8	0.9
0										
1						0.02	0.03	0.04	0.06	0.08
2	0.10	0.12	0.15	0.18	0.21	0.25	0.28	0.32	0.35	0.39
3	0.43	0.47	0.52	0.57	0.61	0.66	0.71	0.76	0.81	0.86
4	0.92	0.98	1.03	1.09	1.15	1.21	1.26	1.32	1.38	1.44
5	1.51	1.58	1.64	1.70	1.76	1.83	1.90	1.97	2.04	2.11
6	2.18	2.25	2.32	2.39	2.47	2.54	2.61	2.68	2.76	2.83
7	2.91	2.98	3.06	3.13	3.21	3.28	3.36	3.44	3.52	3.59
8	3.67	3.75	3.83	3.91	3.99	4.07	4.15	4.23	4.31	4.39
9	4.48	4.56	4.64	4.72	4.80	4.89	4.97	5.05	5.14	5.22
10	5.30	5.39	5.47	5.56	5.64	5.73	5.81	5.90	5.98	6.07

(Curve No. 64)

Inches/Tenths	0.0	0.1	0.2	0.3	0.4	0.5	0.6	0.7	0.8	0.9
0										
1	0.00	0.00	0.00	0.00	0.01	0.02	0.03	0.05	0.07	0.09
2	0.11	0.14	0.17	0.20	0.23	0.26	0.30	0.34	0.38	0.42
3	.47	0.51	0.56	0.60	0.65	0.70	0.75	0.80	0.85	0.91
4	0.97	1.03	1.09	1.15	1.21	1.26	1.32	1.38	1.45	1.51
5	1.58	1.64	1.71	1.77	1.84	1.91	1.98	2.05	2.12	2.19
6	2.26	2.33	2.40	2.48	2.55	2.62	2.70	2.77	2.85	2.92
7	3.00	3.07	3.15	3.23	3.30	3.38	3.46	3.54	3.62	3.69
8	3.77	3.85	3.93	4.01	4.09	4.18	4.26	4.34	4.42	4.50
9	4.59	4.67	4.75	4.84	4.92	5.00	5.09	5.17	5.26	5.34
10	5.43	5.51	5.59	5.68	5.76	5.85	5.94	6.02	6.11	6.20

(Curve No. 65)

Inches/Tenths	0.0	0.1	0.2	0.3	0.4	0.5	0.6	0.7	0.8	0.9
0										
1	0.00	0.00	0.00	0.01	0.02	0.03	0.04	0.06	0.08	0.10
2	0.13	0.16	0.19	0.23	0.26	0.30	0.33	0.37	0.42	0.46
3	0.50	0.55	0.60	0.65	0.70	0.75	0.80	0.86	0.91	0.97
4	1.03	1.09	1.15	1.21	1.27	1.33	1.39	1.45	1.52	1.58
5	1.65	1.72	1.78	1.85	1.92	1.99	2.06	2.13	2.20	2.28
6	2.35	2.42	2.50	2.57	2.64	2.72	2.80	2.87	2.94	3.02
7	3.10	3.18	3.25	3.33	3.41	3.49	3.57	3.64	3.73	3.81
8	3.89	3.97	4.05	4.13	4.22	4.30	4.38	4.46	4.54	4.62
9	4.71	4.80	4.88	4.96	5.05	5.13	5.22	5.30	5.39	5.47
10	5.56	5.65	5.73	5.82	5.90	5.99	6.08	6.17	6.26	6.34

(Curve No. 66)

Inches/Tenths	0.0	0.1	0.2	0.3	0.4	0.5	0.6	0.7	0.8	0.9
0										
1	0.00	0.00	0.01	0.01	0.02	0.04	0.06	0.08	0.10	0.12
2	0.15	0.13	0.21	0.25	0.29	0.33	0.37	0.41	0.45	0.50
3	0.55	0.60	0.65	0.60	0.75	0.80	0.86	0.91	0.97	1.03
4	1.09	1.15	1.21	1.27	1.33	1.39	1.46	1.53	1.59	1.66
5	1.73	1.80	1.87	1.94	2.01	2.08	2.15	2.22	2.29	2.36
6	2.44	2.51	2.59	2.67	2.74	2.82	2.89	2.97	3.05	3.12
7	3.20	3.28	3.36	3.44	3.52	3.60	3.68	3.76	3.84	3.93
8	4.01	4.09	4.17	4.26	4.34	4.43	4.51	4.59	4.67	4.76
9	4.84	4.93	5.01	5.10	5.18	5.27	5.35	5.43	5.50	5.61
10	5.70	5.78	5.87	5.96	6.05	6.13	6.22	6.31	6.40	6.49

(Curve No. 67)

Inches/Tenths	0.0	0.1	0.2	0.3	0.4	0.5	0.6	0.7	0.8	0.9
0										
1	0.00	0.00	0.01	0.02	0.03	0.05	0.07	0.09	0.12	0.15
2	0.18	0.21	0.24	0.28	0.32	0.36	0.40	0.44	0.49	0.54
3	0.59	0.64	0.69	0.74	0.79	0.85	0.91	0.97	1.03	1.09
4	1.15	1.21	1.27	1.34	1.40	1.47	1.53	1.60	1.67	1.74
5	1.81	1.88	1.95	2.02	2.09	2.16	2.23	2.31	2.39	2.46
6	2.54	2.61	2.69	2.76	2.84	2.92	3.00	3.08	3.15	3.23
7	3.31	3.39	3.47	3.55	3.64	3.72	3.80	3.88	3.96	4.04
8	4.13	4.21	4.29	4.38	4.46	4.55	4.63	4.71	4.80	4.89
9	4.97	5.06	5.14	5.23	5.31	5.40	5.49	5.58	5.66	5.75
10	5.84	5.92	6.01	6.10	6.19	6.28	6.36	6.45	6.54	6.63

(Curve No. 68)

Inches/Tenths	0.0	0.1	0.2	0.3	0.4	0.5	0.6	0.7	0.8	0.9
0										
1	0.00	0.01	0.01	0.02	0.04	0.06	0.08	0.11	0.13	0.16
2	0.19	0.23	0.26	0.30	0.34	0.38	0.43	0.48	0.53	0.58
3	0.63	0.68	0.73	0.78	0.84	0.90	0.96	1.02	1.08	1.14
4	1.20	1.26	1.33	1.40	1.47	1.53	1.60	1.67	1.74	1.81
5	1.88	1.95	2.02	2.09	2.16	2.24	2.32	2.39	2.47	2.54
6	2.62	2.70	2.78	2.85	2.93	3.01	3.09	3.17	3.25	3.33
7	3.41	3.49	3.57	3.65	3.73	3.82	3.90	3.99	4.07	4.15
8	4.23	4.32	4.40	4.49	4.57	4.66	4.74	4.83	4.91	5.00
9	5.09	5.17	5.26	5.35	5.43	5.52	5.61	5.70	5.78	5.87
10	5.96	6.05	6.14	6.23	6.32	6.40	6.49	6.58	6.67	6.76

(Curve No. 69)

Inches/Tenths	0.0	0.1	0.2	0.3	0.4	0.5	0.6	0.7	0.8	0.9
0										
1	0.00	0.01	0.02	0.03	0.05	0.07	0.09	0.12	0.15	0.18
2	0.22	0.25	0.29	0.33	0.38	0.42	0.47	0.52	0.57	0.62
3	0.67	0.72	0.78	0.84	0.90	0.96	1.02	1.08	1.14	1.20
4	1.27	1.33	1.40	1.47	1.53	1.60	1.67	1.74	1.81	1.88
5	1.96	2.03	2.10	2.18	2.25	2.33	2.40	2.48	2.56	2.63
6	2.71	2.79	2.87	2.95	3.03	3.11	3.19	3.27	3.35	3.43
7	3.51	3.60	3.68	3.76	3.84	3.93	4.01	4.10	4.18	4.26
8	4.35	4.44	4.52	4.61	4.69	4.78	4.86	4.95	5.04	5.12
9	5.21	5.30	5.39	5.48	5.56	5.65	5.74	5.82	5.91	6.00
10	6.09	6.18	6.27	6.36	6.45	6.54	6.63	6.72	6.81	6.90

(Curve No. 70)

Inches/Tenths	0.0	0.1	0.2	0.3	0.4	0.5	0.6	0.7	0.8	0.9
0										
1	0.00	0.01	0.02	0.04	0.06	0.08	0.11	0.14	0.17	0.20
2	0.24	0.28	0.32	0.36	0.40	0.45	0.50	0.55	0.60	0.65
3	0.71	0.77	0.83	0.89	0.95	1.01	1.07	1.13	1.19	1.25
4	1.33	1.40	1.46	1.53	1.60	1.67	1.74	1.81	1.88	1.96
5	2.04	2.11	2.19	2.26	2.33	2.41	2.49	2.57	2.64	2.72
6	2.80	2.88	2.96	3.04	3.13	3.21	3.29	3.37	3.45	3.53
7	3.61	3.70	3.79	3.87	3.95	4.04	4.12	4.20	4.28	4.37
8	4.46	4.55	4.64	4.72	4.81	4.90	4.98	5.07	5.16	5.25
9	5.33	5.42	5.51	5.60	5.69	5.78	5.87	5.96	6.05	6.14
10	6.23	6.32	6.41	6.50	6.59	6.68	6.77	6.86	6.95	7.04

(Curve No. 71)

Inches/Tenths	0.0	0.1	0.2	0.3	0.4	0.5	0.6	0.7	0.8	0.9
0								0.00	0.00	0.00
1	0.01	0.02	0.03	0.05	0.07	0.10	0.13	0.16	0.19	0.22
2	0.26	0.30	0.34	0.39	0.44	0.49	0.54	0.59	0.64	0.70
3	0.76	0.82	0.88	0.94	1.00	1.06	1.13	1.19	1.26	1.33
4	1.39	1.46	1.53	1.60	1.67	1.74	1.81	1.89	1.97	2.04
5	2.11	2.19	2.27	2.34	2.42	2.50	2.58	2.66	2.74	2.82
6	2.90	2.98	3.06	3.14	3.22	3.30	3.38	3.47	3.55	3.63
7	3.72	3.80	3.88	3.97	4.06	4.14	4.23	4.32	4.40	4.49
8	4.58	4.67	4.75	4.82	4.93	5.02	5.10	5.19	5.28	5.37
9	5.46	5.55	5.64	5.73	5.82	5.90	5.99	6.08	6.17	6.27
10	6.36	6.45	6.54	6.63	6.72	6.81	6.90	6.99	7.08	7.18

(Curve No. 72)

Inches/Tenths	0.0	0.1	0.2	0.3	0.4	0.5	0.6	0.7	0.8	0.9
0									0.00	0.00
1	0.01	0.02	0.04	0.06	0.08	0.11	0.14	0.17	0.21	0.25
2	0.29	0.33	0.38	0.43	0.48	0.53	0.58	0.63	0.69	0.75
3	0.81	0.87	0.93	0.99	1.05	1.12	1.19	1.26	1.32	1.39
4	1.46	1.53	1.60	1.68	1.75	1.82	1.89	1.97	2.05	2.12
5	2.19	2.27	2.35	2.43	2.51	2.59	2.67	2.75	2.83	2.91
6	2.99	3.08	3.16	3.24	3.32	3.41	3.49	3.57	3.66	3.75
7	3.83	3.91	4.00	4.08	4.17	4.26	4.35	4.44	4.52	4.61
8	4.69	4.78	4.87	4.96	5.05	5.14	5.23	5.31	5.40	5.49
9	5.58	5.67	5.76	5.85	5.94	6.03	6.13	6.22	6.31	6.40
10	6.49	6.58	6.67	6.76	6.85	6.95	7.04	7.13	7.22	7.31

(Curve No. 73)

Inches/Tenths	0.0	0.1	0.2	0.3	0.4	0.5	0.6	0.7	0.8	0.9
0	0.00	0.00	0.00	0.00	0.00	0.00	0.00	0.00	0.00	0.01
1	0.02	0.03	0.05	0.07	0.10	0.13	0.16	0.20	0.24	0.28
2	0.32	0.37	0.41	0.46	0.52	0.57	0.62	0.68	0.74	0.80
3	0.86	0.92	0.98	1.04	1.11	1.18	1.25	1.32	1.39	1.46
4	1.53	1.60	1.67	1.75	1.82	1.90	1.97	2.04	2.12	2.20
5	2.28	2.36	2.44	2.52	2.60	2.68	2.76	2.84	2.92	3.00
6	3.09	3.17	3.25	3.34	3.43	3.51	3.60	3.68	3.76	3.85
7	3.94	4.02	4.11	4.20	4.29	4.37	4.46	4.55	4.64	4.73
8	4.81	4.90	4.99	5.08	5.17	5.26	5.35	5.44	5.53	5.62
9	5.71	5.80	5.89	5.98	6.07	6.16	6.25	6.35	6.44	6.53
10	6.62	6.71	6.81	6.90	6.99	7.08	7.17	7.27	7.36	7.45

(Curve No. 74)

Inches/Tenths	0.0	0.1	0.2	0.3	0.4	0.5	0.6	0.7	0.8	0.9
0									0	0.01
1	0.02	0.04	0.06	0.09	0.12	0.15	0.18	0.21	0.27	0.31
2	0.35	0.40	0.45	0.50	0.55	0.61	0.67	0.73	0.79	0.85
3	0.91	0.97	1.04	1.11	1.18	1.25	1.32	1.38	1.45	1.52
4	1.60	1.68	1.75	1.83	1.90	1.98	2.06	2.13	2.21	2.29
5	2.37	2.45	2.53	2.61	2.69	2.78	2.86	2.94	3.02	3.10
6	3.19	3.28	3.36	3.45	3.53	3.62	3.70	3.79	3.88	3.96
7	4.05	4.14	4.23	4.31	4.39	4.48	4.57	4.66	4.75	4.84
8	4.93	5.02	5.11	5.20	5.29	5.38	5.47	5.56	5.65	5.75
9	5.84	5.93	6.02	6.11	6.20	6.29	6.38	6.47	6.56	6.65
10	6.75	6.84	6.94	7.03	7.12	7.21	7.30	7.40	7.50	7.60

(Curve No. 75)

Inches/Tenths	0.0	0.1	0.2	0.3	0.4	0.5	0.6	0.7	0.8	0.9
0	0.00	0.00	0.00	0.00	0.00	0.00	0.00	0.00	0.00	0.01
1	0.03	0.05	0.07	0.10	0.13	0.16	0.20	0.24	0.28	0.33
2	0.38	0.43	0.48	0.53	0.59	0.65	0.71	0.77	0.83	0.89
3	0.95	1.02	1.09	1.16	1.23	1.30	1.37	1.44	1.52	1.59
4	1.67	1.74	1.82	1.89	1.97	2.04	2.12	2.20	2.28	2.36
5	2.44	2.52	2.61	2.69	2.77	2.85	2.94	3.02	3.11	3.19
6	3.27	3.36	3.45	3.53	3.62	3.71	3.79	3.88	3.97	4.06
7	4.15	4.24	4.32	4.40	4.49	4.58	4.67	4.76	4.86	4.95
8	5.04	5.13	5.22	5.31	5.40	5.49	5.58	5.67	5.76	5.85
9	5.94	6.04	6.13	6.22	6.32	6.41	6.50	6.59	6.68	6.78
10	6.87	6.96	7.05	7.15	7.24	7.34	7.43	7.53	7.63	7.73

(Curve No. 76)

Inches/Tenths	0.0	0.1	0.2	0.3	0.4	0.5	0.6	0.7	0.8	0.9
0	0.00	0.00	0.00	0.00	0.00	0.00	0.00	0.00	0.01	0.02
1	0.04	0.06	0.08	0.11	0.15	0.19	0.23	0.27	0.31	0.36
2	0.41	0.46	0.51	0.57	0.63	0.69	0.75	0.81	0.88	0.95
3	1.01	1.08	1.15	1.22	1.29	1.36	1.43	1.51	1.58	1.66
4	1.74	1.81	1.89	1.97	2.05	2.13	2.21	2.29	2.37	2.46
5	2.54	2.62	2.70	2.78	2.87	2.95	3.04	3.12	3.21	3.29
6	3.38	3.47	3.55	3.64	3.73	3.81	3.90	3.99	4.08	4.17
7	4.26	4.35	4.44	4.53	4.62	4.71	4.80	4.89	4.98	5.07
8	5.16	5.25	5.34	5.43	5.52	5.61	5.70	5.80	5.89	5.98
9	6.07	6.17	6.26	6.35	6.45	6.54	6.63	6.73	6.82	6.91
10	7.01	7.10	7.19	7.28	7.37	7.47	7.57	7.66	7.75	7.85

(Curve No. 77)

Inches/Tenths	0.0	0.1	0.2	0.3	0.4	0.5	0.6	0.7	0.8	0.9
0	0.00	0.00	0.00	0.00	0.00	0.00	0.00	0.00	0.01	0.03
1	0.05	0.07	0.10	0.14	0.18	0.22	0.26	0.30	0.34	0.39
2	0.45	0.50	0.56	0.62	0.68	0.74	0.80	0.86	0.93	1.00
3	1.07	1.14	1.21	1.28	1.35	1.43	1.50	1.57	1.65	1.73
4	1.81	1.89	1.97	2.05	2.13	2.21	2.29	2.37	2.45	2.53
5	2.62	2.70	2.79	2.87	2.96	3.04	3.13	3.22	3.30	3.39
6	3.48	3.56	3.65	3.74	3.83	3.92	4.00	4.09	4.18	4.27
7	4.36	4.45	4.54	4.63	4.72	4.81	4.90	5.00	5.09	5.18
8	5.27	5.36	5.45	5.55	5.64	5.73	5.82	5.92	6.01	6.10
9	6.19	6.29	6.38	6.47	6.57	6.66	6.76	6.85	6.94	7.04
10	7.13	7.23	7.32	7.42	7.51	7.60	7.70	7.79	7.89	7.98

(Curve No. 77)

(Curve No. 78)

Inches/Tenths	0.0	0.1	0.2	0.3	0.4	0.5	0.6	0.7	0.8	0.9
0	0.00	0.00	0.00	0.00	0.00	0.00	0.00	0.01	0.02	0.03
1	0.06	0.09	0.12	0.15	0.19	0.23	0.27	0.32	0.37	0.42
2	0.48	0.54	0.60	0.66	0.72	0.79	0.86	0.93	0.99	1.06
3	1.13	1.20	1.27	1.35	1.43	1.50	1.58	1.65	1.73	1.81
4	1.89	1.97	2.05	2.13	2.22	2.30	2.38	2.46	2.54	2.63
5	2.72	2.81	2.89	2.98	3.06	3.15	3.24	3.32	3.41	3.50
6	3.59	3.67	3.76	3.85	3.94	4.03	4.12	4.22	4.31	4.39
7	4.48	4.58	4.67	4.76	4.85	4.94	5.03	5.12	5.22	5.31
8	5.40	5.49	5.58	5.67	5.77	5.86	5.95	6.05	6.14	6.24
9	6.33	6.43	6.52	6.61	6.71	6.80	6.90	6.99	7.09	7.18
10	7.27	7.37	7.46	7.56	7.65	7.75	7.84	7.94	8.04	8.13

(Curve No. 79)

Inches/Tenths	0.0	0.1	0.2	0.3	0.4	0.5	0.6	0.7	0.8	0.9
0	0.00	0.00	0.00	0.00	0.00	0.00	0.00	0.01	0.03	0.05
1	0.07	0.10	0.13	0.17	0.21	0.26	0.31	0.36	0.41	0.46
2	0.52	0.58	0.64	0.70	0.77	0.84	0.91	0.98	1.05	1.12
3	1.19	1.26	1.34	1.42	1.49	1.56	1.64	1.72	1.80	1.88
4	1.96	2.04	2.13	2.21	2.29	2.38	2.46	2.55	2.63	2.72
5	2.80	2.89	2.98	3.07	3.15	3.24	3.32	3.41	3.50	3.59
6	3.68	3.77	3.86	3.95	4.04	4.13	4.22	4.31	4.40	4.49
7	4.58	4.68	4.77	4.86	4.95	5.04	5.13	5.23	5.32	5.42
8	5.51	5.60	5.68	5.78	5.88	5.98	6.07	6.16	6.26	6.35
9	6.45	6.54	6.63	6.73	6.82	6.92	7.01	7.11	7.20	7.30
10	7.39	7.49	7.58	7.68	7.77	7.87	7.97	8.06	8.16	8.25

(Curve No. 80)

Inches/Tenths	0.0	0.1	0.2	0.3	0.4	0.5	0.6	0.7	0.8	0.9
0	0.00	0.00	0.00	0.00	0.00	0.00	0.00	0.01	0.03	0.05
1	0.08	0.11	0.15	0.19	0.24	0.29	0.34	0.39	0.44	0.50
2	0.56	0.62	0.68	0.75	0.82	0.89	0.96	1.03	1.10	1.17
3	1.25	1.33	1.40	1.48	1.56	1.64	1.72	1.80	1.88	1.96
4	2.04	2.12	2.20	2.29	2.38	2.46	2.55	2.63	2.72	2.81
5	2.89	2.98	3.07	3.16	3.25	3.34	3.43	3.52	3.61	3.69
6	3.78	3.87	3.96	4.05	4.14	4.23	4.32	4.42	4.51	4.60
7	4.69	4.79	4.88	4.97	5.06	5.16	5.25	5.34	5.44	5.53
8	5.62	5.72	5.81	5.91	6.00	6.09	6.19	6.28	6.38	6.47
9	6.57	6.66	6.76	6.85	6.95	7.04	7.14	7.23	7.33	7.43
10	7.52	7.62	7.71	7.81	7.90	8.00	8.10	8.19	8.29	8.38

(Curve No. 81)

Inches/Tenths	0.0	0.1	0.2	0.3	0.4	0.5	0.6	0.7	0.8	0.9
0	0.00	0.00	0.00	0.00	0.00	0.00	0.01	0.02	0.04	0.07
1	0.10	0.13	0.17	0.21	0.26	0.31	0.36	0.42	0.48	0.54
2	0.60	0.66	0.73	0.80	0.87	0.94	1.01	1.09	1.16	1.23
3	1.31	1.39	1.47	1.55	1.63	1.71	1.79	1.87	1.95	2.03
4	2.12	2.20	2.29	2.37	2.46	2.55	2.63	2.72	2.81	2.89
5	2.98	3.07	3.16	3.25	3.34	3.43	3.52	3.61	3.70	3.79
6	3.88	3.97	4.06	4.16	4.25	4.34	4.43	4.52	4.61	4.71
7	4.80	4.90	4.99	5.08	5.17	5.27	5.36	5.46	5.55	5.64
8	5.74	5.84	5.93	6.02	6.11	6.20	6.29	6.39	6.49	6.59
9	6.69	6.79	6.88	6.97	7.06	7.15	7.25	7.35	7.45	7.55
10	7.64	7.74	7.84	7.93	8.03	8.12	8.21	8.31	8.41	8.51

(Curve No. 82)

Inches/Tenths	0.0	0.1	0.2	0.3	0.4	0.5	0.6	0.7	0.8	0.9
0	0.00	0.00	0.00	0.00	0.00	0.00	0.01	0.03	0.05	0.08
1	0.11	0.15	0.19	0.24	0.29	0.34	0.40	0.46	0.52	0.58
2	0.65	0.72	0.78	0.85	0.92	0.99	1.06	1.14	1.22	1.30
3	1.38	1.46	1.53	1.61	1.69	1.77	1.86	1.94	2.02	2.11
4	2.20	2.29	2.38	2.46	2.55	2.64	2.73	2.81	2.90	2.99
5	3.08	3.17	3.26	3.35	3.44	3.53	3.62	3.71	3.80	3.89
6	3.98	4.07	4.17	4.26	4.35	4.45	4.54	4.63	4.73	4.82
7	4.91	5.01	5.11	5.20	5.29	5.39	5.48	5.57	5.67	5.76
8	5.86	5.95	6.05	6.14	6.24	6.33	6.43	6.53	6.62	6.71
9	6.81	6.91	7.01	7.11	7.21	7.30	7.40	7.49	7.59	7.68
10	7.77	7.87	7.97	8.07	8.17	8.26	8.36	8.46	8.55	8.64

(Curve No. 83)

Inches/Tenths	0.0	0.1	0.2	0.3	0.4	0.5	0.6	0.7	0.8	0.9
0	0.00	0.00	0.00	0.00	0.00	0.00	0.02	0.04	0.06	0.09
1	0.13	0.17	0.22	0.27	0.32	0.38	0.44	0.50	0.56	0.63
2	0.70	0.76	0.83	0.91	0.98	1.06	1.13	1.21	1.29	1.37
3	1.45	1.53	1.61	1.69	1.77	1.86	1.94	2.02	2.11	2.20
4	2.29	2.37	2.46	2.55	2.64	2.73	2.82	2.91	3.00	3.08
5	3.17	3.26	3.35	3.45	3.54	3.63	3.72	3.81	3.90	4.00
6	4.09	4.18	4.28	4.37	4.46	4.55	4.65	4.74	4.84	4.93
7	5.02	5.12	5.21	5.31	5.40	5.50	5.60	5.69	5.78	5.88
8	5.98	6.07	6.17	6.26	6.36	6.45	6.55	6.65	6.74	6.84
9	6.93	7.03	7.13	7.22	7.32	7.42	7.51	7.61	7.71	7.80
10	7.90	8.00	8.09	8.19	8.29	8.39	8.48	8.58	8.68	8.77

(Curve No. 84)

Inches/Tenths	0.0	0.1	0.2	0.3	0.4	0.5	0.6	0.7	0.8	0.9
0	0.00	0.00	0.00	0.00	0.00	0.01	0.02	0.05	0.08	0.11
1	0.15	0.20	0.25	0.30	0.35	0.41	0.48	0.54	0.61	0.68
2	0.74	0.82	0.89	0.97	1.04	1.12	1.20	1.28	1.36	1.44
3	1.52	1.60	1.68	1.77	1.85	1.94	2.03	2.11	2.20	2.29
4	2.37	2.46	2.55	2.64	2.73	2.82	2.91	3.00	3.09	3.18
5	3.27	3.37	3.46	3.55	3.64	3.73	3.82	3.92	4.01	4.11
6	4.20	4.29	4.39	4.48	4.58	4.67	4.76	4.86	4.95	5.05
7	5.14	5.24	5.33	5.43	5.52	5.62	5.71	5.81	5.91	6.00
8	6.10	6.20	6.30	6.39	6.48	6.58	6.68	6.77	6.87	6.97
9	<b>7.06</b>	7.16	7.26	7.35	7.45	7.55	7.65	7.74	7.84	7.94
10	<b>8.03</b>	8.13	8.23	8.33	8.42	8.52	8.61	8.71	8.81	8.91

(Curve No. 85)

Inches/Tenths	0.0	0.1	0.2	0.3	0.4	0.5	0.6	0.7	0.8	0.9
0	0.00	0.00	0.00	0.00	0.00	0.01	0.03	0.06	0.09	0.13
1	0.18	0.22	0.28	0.33	0.39	0.45	0.52	0.59	0.65	0.73
2	0.80	0.87	0.95	1.02	1.10	1.18	1.26	1.34	1.42	1.51
3	1.59	1.68	1.76	1.85	1.93	2.02	2.11	2.20	2.28	2.37
4	2.46	2.55	2.64	2.73	2.82	2.91	3.00	3.09	3.19	3.28
5	3.37	3.47	3.56	3.65	3.74	3.84	3.93	4.03	4.12	4.21
6	4.31	4.40	4.50	4.59	4.69	4.78	4.87	4.97	5.06	5.16
7	5.26	5.35	5.45	5.55	5.64	5.74	5.84	5.93	6.03	6.12
8	6.22	6.32	6.41	6.50	6.60	6.70	6.80	6.90	6.99	7.09
9	7.19	7.28	7.38	7.48	7.57	7.67	7.77	7.87	7.97	8.06
10	8.16	8.26	8.35	8.45	8.55	8.65	8.75	8.84	8.94	9.04

(Curve No. 86)

Inches/Tenths	0.0	0.1	0.2	0.3	0.4	0.5	0.6	0.7	0.8	0.9
0	0.00	0.00	0.00	0.00	0.00	0.02	0.04	0.07	0.11	0.15
1	0.20	0.25	0.30	0.36	0.42	0.49	0.56	0.63	0.70	0.77
2	0.85	0.92	1.00	1.08	1.16	1.24	1.33	1.41	1.49	1.57
3	1.66	1.74	1.83	1.92	2.00	2.09	2.18	2.27	2.36	2.45
4	2.54	2.63	2.72	2.81	2.91	3.00	3.09	3.18	3.28	3.37
5	3.46	3.56	3.65	3.74	3.83	3.93	4.02	4.12	4.21	4.31
6	4.40	4.50	4.59	4.69	4.78	4.88	4.98	5.07	5.17	5.27
7	5.36	5.46	5.55	5.65	5.74	5.84	5.94	6.03	6.13	6.22
8	6.32	6.42	6.52	6.61	6.71	6.81	6.91	7.01	7.10	7.20
9	7.30	7.40	7.50	7.60	7.70	7.79	7.88	7.98	8.08	8.18
10	8.27	8.37	8.47	8.57	8.67	8.76	8.86	8.96	9.06	9.16

(Curve No. 87)

Inches/Tenths	0.0	0.1	0.2	0.3	0.4	0.5	0.6	0.7	0.8	0.9
0	0.00	0.00	0.00	0.00	0.00	0.02	0.05	0.08	0.13	0.17
1	0.22	0.28	0.34	0.40	0.47	0.54	0.61	0.69	0.75	0.83
2	0.91	0.98	1.06	1.15	1.23	1.31	1.39	1.47	1.56	1.65
3	1.74	1.83	1.92	2.01	2.09	2.18	2.27	2.36	2.45	2.55
4	2.64	2.73	2.82	2.91	3.01	3.10	3.19	3.28	3.38	3.47
5	3.57	3.67	3.76	3.85	3.95	4.04	4.13	4.23	4.32	4.42
6	4.51	4.61	4.71	4.80	4.90	5.00	5.09	5.19	5.29	5.38
7	5.48	5.58	5.67	5.77	5.87	5.97	6.06	6.16	6.25	6.35
8	6.45	6.55	6.64	6.74	6.84	6.94	7.03	7.13	7.23	7.33
9	7.43	7.52	7.62	7.72	7.81	7.91	8.01	8.11	8.21	8.31
10	8.41	8.51	8.61	8.70	8.80	8.90	9.00	9.10	9.20	9.30

(Curve No. 88)

Inches/Tenths	0.0	0.1	0.2	0.3	0.4	0.5	0.6	0.7	0.8	0.9
0	0.00	0.00	0.00	0.00	0.01	0.03	0.06	0.10	0.15	0.20
1	0.25	0.31	0.38	0.44	0.51	0.58	0.65	0.73	0.81	0.88
2	0.96	1.04	1.12	1.21	1.30	1.38	1.47	1.55	1.64	1.73
3	1.82	1.90	1.99	2.08	2.17	2.26	2.35	2.44	2.54	2.63
4	2.72	2.82	2.91	3.00	3.10	3.19	3.29	3.38	3.47	3.57
5	3.66	3.76	3.85	3.95	4.05	4.14	4.23	4.33	4.42	4.52
6	4.62	4.72	4.81	4.91	5.01	5.10	5.20	5.29	5.39	5.49
7	5.58	5.68	5.78	5.88	5.97	6.07	6.17	6.27	6.36	6.46
8	6.56	6.66	6.75	6.85	6.95	7.05	7.15	7.24	7.34	7.44
9	7.54	7.64	7.73	7.83	7.93	8.03	8.13	8.23	8.33	8.43
10	8.53	8.63	8.73	8.83	8.93	9.03	9.12	9.22	9.32	9.42

(Curve No. 89)

Inches/Tenths	0.0	0.1	0.2	0.3	0.4	0.5	0.6	0.7	0.8	0.9
0	0.00	0.00	0.00	0.00	0.02	0.04	0.08	0.12	0.17	0.22
1	0.28	0.35	0.41	0.48	0.55	0.63	0.71	0.78	0.86	0.94
2	1.03	1.11	1.19	1.28	1.37	1.46	1.54	1.63	1.72	1.81
3	1.90	1.99	2.08	2.17	2.26	2.36	2.45	2.54	2.64	2.73
4	2.82	2.92	3.01	3.11	3.20	3.30	3.39	3.49	3.58	3.68
5	3.77	3.87	3.96	4.06	4.16	4.25	4.35	4.45	4.54	4.64
6	4.74	4.83	4.93	5.02	5.12	5.22	5.32	5.42	5.51	5.61
7	5.71	5.80	5.90	6.00	6.10	6.20	6.30	6.39	6.49	6.59
8	6.69	6.79	6.88	6.98	7.08	7.18	7.28	7.38	7.47	7.57
9	7.67	7.77	7.87	7.97	8.06	8.16	8.26	8.36	8.46	8.56
10	8.66	8.76	8.86	8.95	9.05	9.15	9.25	9.35	9.45	9.55

(Curve No. 90)

Inches/Tenths	0.0	0.1	0.2	0.3	0.4	0.5	0.6	0.7	0.8	0.9
0	0.00	0.00	0.00	0.01	0.03	0.06	0.10	0.15	0.20	0.26
1	0.32	0.39	0.46	0.53	0.61	0.69	0.77	0.85	0.93	1.01
2	1.10	1.18	1.27	1.35	1.44	1.53	1.62	1.71	1.80	1.89
3	1.99	2.08	2.17	2.26	2.36	2.45	2.54	2.64	2.73	2.83
4	2.92	3.02	3.11	3.20	3.30	3.40	3.49	3.59	3.69	3.78
5	3.88	3.97	4.07	4.17	4.26	4.36	4.46	4.56	4.65	4.75
6	4.85	4.95	5.04	5.14	5.24	5.34	5.44	5.54	5.63	5.73
7	5.83	5.92	6.02	6.12	6.21	6.31	6.41	6.51	6.61	6.71
8	6.81	6.91	7.01	7.11	7.20	7.30	7.40	7.50	7.60	7.70
9	7.79	7.89	7.99	8.09	8.19	8.29	8.39	8.49	8.58	8.68
10	8.78	8.88	8.98	9.08	9.18	9.28	9.38	9.48	9.57	9.67

(Curve No. 91)

Inches/Tenths	0.0	0.1	0.2	0.3	0.4	0.5	0.6	0.7	0.8	0.9
0	0.00	0.00	0.00	0.01	0.03	0.07	0.12	0.17	0.23	0.29
1	0.36	0.43	0.50	0.58	0.66	0.74	0.82	0.91	0.99	1.08
2	1.17	1.25	1.34	1.43	1.52	1.61	1.70	1.80	1.89	1.98
3	2.07	2.16	2.26	2.35	2.44	2.54	2.63	2.73	2.83	2.92
4	3.02	3.11	3.21	3.30	3.40	3.50	3.59	3.69	3.79	3.89
5	3.99	4.08	4.17	4.27	4.37	4.47	4.56	4.66	4.76	4.86
6	4.96	5.05	5.15	5.25	5.34	5.44	5.54	5.64	5.74	5.84
7	5.94	6.04	6.14	6.24	6.34	6.44	6.53	6.63	6.73	6.83
8	6.93	7.03	7.13	7.23	7.33	7.43	7.52	7.62	7.72	7.82
9	7.92	8.02	8.12	8.22	8.31	8.41	8.51	8.61	8.71	8.81
10	8.91	9.01	9.11	9.21	9.31	9.41	9.51	9.61	9.71	9.80

(Curve No. 92)

Inches/Tenths	0.0	0.1	0.2	0.3	0.4	0.5	0.6	0.7	0.8	0.9
0	0.00	0.00	0.00	0.02	0.05	0.09	0.14	0.20	0.26	0.33
1	0.41	0.48	0.56	0.64	0.72	0.80	0.89	0.97	1.06	1.15
2	1.24	1.33	1.42	1.51	1.60	1.69	1.78	1.88	1.98	2.07
3	2.16	2.26	2.35	2.45	2.54	2.64	2.74	2.83	2.93	3.02
4	3.12	3.22	3.31	3.41	3.51	3.60	3.70	3.80	3.90	4.00
5	4.09	4.19	4.29	4.39	4.48	4.58	4.68	4.78	4.88	4.97
6	5.07	5.17	5.27	5.37	5.47	5.56	5.66	5.76	5.86	5.96
7	6.06	6.15	6.25	6.35	6.45	6.55	6.65	6.75	6.85	6.95
8	7.05	7.15	7.25	7.34	7.44	7.54	7.64	7.74	7.84	7.94
9	8.04	8.14	8.24	8.33	8.43	8.53	8.63	8.73	8.83	8.93
10	9.03	9.13	9.23	9.33	9.43	9.53	9.63	9.73	9.83	9.93

(Curve No. 93)

Inches/Tenths	0.0	0.1	0.2	0.3	0.4	0.5	0.6	0.7	0.8	0.9
0	0.00	0.00	0.00	0.03	0.06	0.11	0.17	0.23	0.30	0.38
1	0.45	0.53	0.61	0.70	0.78	0.87	0.96	1.04	1.13	1.22
2	1.32	1.41	1.50	1.59	1.69	1.78	1.88	1.97	2.06	2.16
3	2.26	2.35	2.45	2.54	2.64	2.74	2.83	2.93	3.03	3.12
4	3.22	3.32	3.42	3.51	3.61	3.71	3.81	3.91	4.00	4.10
5	4.20	4.30	4.40	4.50	4.59	4.69	4.79	4.89	4.99	5.09
6	5.18	5.28	5.38	5.48	5.58	5.68	5.78	5.88	5.97	6.07
7	6.17	6.27	6.37	6.47	6.57	6.67	6.77	6.87	6.97	7.07
8	7.17	7.26	7.36	7.46	7.56	7.66	7.76	7.86	7.96	8.06
9	8.16	8.26	8.36	8.46	8.56	8.66	8.75	8.85	8.95	9.05
10	9.15	9.25	9.35	9.45	9.55	9.65	9.75	9.85	9.95	10.05

(Curve No. 94)

Inches/Tenths	0.0	0.1	0.2	0.3	0.4	0.5	0.6	0.7	0.8	0.9
0	0.00	0.00	0.01	0.04	0.08	0.14	0.20	0.27	0.34	0.42
1	0.50	0.58	0.67	0.76	0.84	0.93	1.02	1.11	1.21	1.30
2	1.39	1.49	1.58	1.68	1.77	1.87	1.97	2.06	2.15	2.24
3	2.35	2.44	2.54	2.64	2.73	2.83	2.93	3.03	3.13	3.22
4	3.32	3.42	3.52	3.62	3.72	3.81	3.91	4.01	4.11	4.21
5	4.30	4.40	4.50	4.60	4.70	4.80	4.90	5.00	5.10	5.19
6	5.29	5.39	5.49	5.59	5.69	5.79	5.89	5.99	6.09	6.18
7	6.28	6.38	6.48	6.58	6.68	6.78	6.88	6.98	7.08	7.18
8	7.27	7.37	7.47	7.57	7.67	7.77	7.87	7.97	8.07	8.17
9	8.27	8.37	8.47	8.57	8.67	8.77	8.87	8.97	9.07	9.17
10	9.27	9.37	9.47	9.57	9.67	9.77	9.87	9.97	10.07	10.17

(Curve No. 95)

Inches/Tenths	0.0	0.1	0.2	0.3	0.4	0.5	0.6	0.7	0.8	0.9
0	0.00	0.00	0.01	0.05	0.11	0.17	0.24	0.32	0.40	0.48
1	0.56	0.65	0.74	0.83	0.92	1.01	1.11	1.20	1.30	1.39
2	1.48	1.58	1.68	1.78	1.87	1.97	2.07	2.16	2.26	2.36
3	2.44	2.54	2.64	2.74	2.84	2.93	3.03	3.13	3.23	3.32
4	3.42	3.52	3.62	3.72	3.82	3.92	4.02	4.12	4.21	4.31
5	4.41	4.51	4.61	4.71	4.81	4.91	5.01	5.11	5.21	5.30
6	5.40	5.50	5.60	5.70	5.80	5.90	6.00	6.10	6.20	6.30
7	6.40	6.50	6.60	6.70	6.80	6.90	7.00	7.10	7.19	7.29
8	7.39	7.49	7.59	7.69	7.79	7.89	7.99	8.09	8.19	8.29
9	8.39	8.49	8.59	8.69	8.79	8.89	8.99	9.09	9.19	9.29
10	9.39	9.49	9.59	9.69	9.79	9.89	9.99	10.09	10.19	10.29

(Curve No. 96)

Inches/Tenths	0.0	0.1	0.2	0.3	0.4	0.5	0.6	0.7	0.8	0.9
0	0.00	0.01	0.04	0.08	0.14	0.22	0.29	0.37	0.46	0.55
1	0.64	0.73	0.82	0.91	1.01	1.10	1.20	1.29	1.31	1.48
2	1.58	1.68	1.77	1.87	1.97	2.07	2.17	2.26	2.36	2.46
3	2.56	2.66	2.76	2.86	2.95	3.05	3.15	3.25	3.35	3.45
4	3.55	3.65	3.75	3.85	3.95	4.05	4.14	4.24	4.34	4.44
5	4.54	4.64	4.74	4.84	4.94	5.04	5.14	5.24	5.34	5.44
6	5.54	5.64	5.74	5.84	5.93	6.03	6.13	6.23	6.33	6.43
7	6.53	6.63	6.73	6.83	6.93	7.03	7.13	7.23	7.33	7.43
8	7.53	7.63	7.73	7.83	7.93	8.03	8.13	8.23	8.33	8.43
9	8.53	8.63	8.73	8.83	8.93	9.03	9.13	9.23	9.33	9.43
10	9.53	9.63	9.73	9.83	9.93	10.03	10.13	10.23	10.32	10.42

(Curve No. 97)

Inches/Tenths	0.0	0.1	0.2	0.3	0.4	0.5	0.6	0.7	0.8	0.9
0	0.00	0.00	0.04	0.11	0.18	0.26	0.35	0.44	0.53	0.62
1	0.71	0.81	0.90	1.00	1.10	1.19	1.29	1.39	1.49	1.58
2	1.68	1.78	1.88	1.98	2.08	2.17	2.27	2.37	2.47	2.57
3	2.67	2.77	2.87	2.97	3.07	3.16	3.26	3.36	3.46	3.56
4	3.66	3.76	3.86	3.96	4.06	4.16	4.26	4.36	4.46	4.56
5	4.66	4.76	4.86	4.96	5.06	5.16	5.26	5.36	5.46	5.55
6	5.65	5.75	5.85	5.95	6.05	6.15	6.25	6.35	6.45	6.55
7	6.65	6.75	6.85	6.95	7.05	7.15	7.25	7.35	7.45	7.55
8	7.65	7.75	7.85	7.95	8.05	8.15	8.25	8.35	8.45	8.55
9	8.65	8.75	8.85	8.95	9.05	9.15	9.25	9.35	9.45	9.55
10	9.65	9.75	9.85	9.95	10.05	10.15	10.25	10.35	10.45	10.55

(Curve No. 98)

Inches/Tenths	0.0	0.1	0.2	0.3	0.4	0.5	0.6	0.7	0.8	0.9
0	0.00	0.01	0.07	0.15	0.23	0.32	0.41	0.51	0.60	0.69
1	0.79	0.89	0.99	1.09	1.19	1.28	1.38	1.48	1.58	1.68
2	1.78	1.88	1.98	2.08	2.18	2.27	2.37	2.47	2.57	2.67
3	2.77	2.87	2.97	3.07	3.17	3.27	3.37	3.47	3.57	3.67
4	3.77	3.87	3.97	4.07	4.17	4.27	4.37	4.47	4.57	4.67
5	4.77	4.87	4.97	5.07	5.17	5.27	5.37	5.47	5.57	5.67
6	5.77	5.87	5.97	6.07	6.17	6.27	6.37	6.47	6.57	6.67
7	6.77	6.87	6.98	7.07	7.17	7.27	7.37	7.47	7.57	7.67
8	7.76	7.86	7.96	8.06	8.16	8.26	8.36	8.46	8.56	8.66
9	8.76	8.86	8.96	9.06	9.16	9.26	9.36	9.46	9.56	9.66
10	9.76	9.86	9.96	10.06	10.16	10.26	10.36	10.46	10.56	10.66

**EXHIBIT 2-7**

**SURFACE RUNOFF AND PEAK DISCHARGE COMPUTATION SHEET**

Type of Structure: \_\_\_\_\_

Drainage Area: \_\_\_\_\_ Number: \_\_\_\_\_ Acres: \_\_\_\_\_

County: \_\_\_\_\_ Date: \_\_\_\_\_  
 Rainfall Frequency \_\_\_\_\_ Years Rainfall \_\_\_\_\_ Inches  
 Average Watershed Slope \_\_\_\_\_ Percent

HYDROLOGIC SOIL GROUP	LAND USE	TREATMENT OR PRACTICE	RUNOFF CURVE NUMBER	ACRE (Ac.)	Col. 4X Col.5
1	2	3	4	5	6
TOTALS =					

Weighted Runoff Curve No. =  $\frac{\text{Total Col. 6}}{\text{Total Col. 5}}$  = \_\_\_\_\_ = \_\_\_\_\_ Use \_\_\_\_\_

**SLOPE INTERPOLATION**

q(1) For \_\_\_\_\_ RCN(1) = q(Exhibit 2-4 or 2-4A for \_\_\_\_\_ Slopes) X Slope Correction Factor  
 = \_\_\_\_\_ X \_\_\_\_\_ = \_\_\_\_\_ cfs  
 q(2) For \_\_\_\_\_ RCN(2) = \_\_\_\_\_ X \_\_\_\_\_ = \_\_\_\_\_ cfs

**CURVE NUMBER INTERPOLATION**

Watershed RCN Minus RCN (1)	C
1	.2
2	.4
3	.6
4	.8

q(2) - q(1) = \_\_\_\_\_ - \_\_\_\_\_ = \_\_\_\_\_ cfs  
 q(‘) = q (2) - q (1) X c = \_\_\_\_\_ X \_\_\_\_\_ = \_\_\_\_\_ cfs  
 Peak Discharge = q(1) + q(‘) = \_\_\_\_\_ + \_\_\_\_\_ = \_\_\_\_\_ cfs  
 Runoff = \_\_\_\_\_ Inches/Acre

# 3 Sediment Dams - Embankment Type CONTENTS

Definition		1
Scope		1
Principal Spillways		2
	<i>Definition – Scope – Capacity – Layout – Pipe Conduits</i>	2
	<i>Drop Inlet</i>	4
	<i>Hooded Inlet</i>	5
Emergency Spillways		5
	<i>Capacity – Design - Layout</i>	6
	<i>Permissible Velocities</i>	7
	<i>Concrete Emergency Spillways</i>	8
Earth Embankment		8
	<i>Height – Top Width</i>	8
	<i>Side Slopes -Cutoff Trench – Settlement Allowance – Utilities Under Embankments – Vegetative Protection Against Erosion - Safety</i>	9
Plans, Design Data and Specifications		9
Construction Specifications for Sediment Dams, Embankment Type		10
	<i>Site Preparation – Cutoff Trench</i>	10
	<i>Excavation and Backfill of Stream Channel – Pipe Conduit – Emergency Spillway – Borrow Areas – Selection and Placement of Embankment Materials Protection Against Erosion</i>	11
Exhibits		
	<i>Exhibit 3-1</i>	13
	<i>Exhibit 3-2</i>	16
	<i>Exhibit 3-3</i>	17
	<i>There is NO Exhibit 3-4</i>	
	<i>Exhibit 3-5</i>	18
	<i>Chart 3-1</i>	19
	<i>Chart 3-2</i>	19
	<i>Table 3-1</i>	20
	<i>Table 3-2</i>	20

## SEDIMENT DAMS, EMBANKMENT TYPE

### 3.1 DEFINITION

A barrier or dam constructed across waterway or other suitable locations to form a silt or sediment basin with a minimum of 3 feet of water impounded against the barrier or dam at normal pool elevation, which elevation is defined as the crest of the principal spillway.

### 3.2 SCOPE

This chapter establishes the minimum acceptable quality for the design and construction of sediment dams, embankment type, located in predominantly rural or agricultural areas in West Virginia when:

1. Failure of the structure would not result in loss of life; in damages to homes, commercial or industrial buildings; main highways, or railroads; in interruption of the use of service of public utilities; or damage existing water impoundments; and
2. The contributing drainage area does not exceed (500) acres; if contributing drainage area exceeds 200 acres but is less than 500 acres, the principal spillway and emergency spillway shall meet the minimum design criteria as outlined in Chart Numbers 3-1 and 3-2; and
3. The vertical distance between the upstream toe of the embankment and to the crest of the emergency spillway does not exceed 20 feet in height or storage volume does not exceed 20 acre-feet as measured at the emergency spillway crest elevation when the embankment height as measured from the upstream toe to the crest of the emergency spillway exceeds 5 feet, and also does not present a hazard to coal miners as determined by the Mine Safety and Health Administration. Structures which exceed the conditions outlined in Section 3.2(3) shall comply with the following minimum standards:
  - a. An appropriate combination of principal and emergency spillways shall be provided to discharge safely the runoff resulting from a 100 year, 24-hour precipitation event, or a larger event specified by the Department of Natural Resources.
  - b. The embankment shall be designed and constructed with a static safety factor of at least 1.5, or a higher safety factor as designated by the Department of Environmental Protection to ensure long term stability.
  - c. Appropriate barriers shall be provided to control seepage along the conduits that extend through the embankment.
  - d. The criteria of the Mine Safety and Health Administration as published in 30 C.F.R. 77.216 shall be adhered to. All inspection reports and approvals shall be provided to the Director of the Department of Environmental Protection Mining and Reclamation.
4. Structures which is or will exceed twenty-five feet in vertical height from the natural bed of such stream or watercourse measured at the downstream toe of the barrier and which does or can impound fifty acre-feet or more of water. Structures meeting these minimum requirements

must be approved by the Director of the Department of Environmental Protection Mining and Reclamation in accordance with Chapter 22 Article 14 of the Code of West Virginia known as "Dam Control Act."

### 3.3 PRINCIPAL SPILLWAYS

#### 3.3.1 Definition

The principal spillway is constructed of permanent material, and usually is designed to provide flood protection or to reduce the frequency of operation of the emergency spillway. Two types of principal spillways are drop inlet and hooded inlet.

#### 3.3.2 Scope

A drop inlet or hooded inlet principal spillway will be required on all sediment dams, embankment type. The crest of the principal spillway shall be located at the maximum elevation of the sediment pool. The principal spillway shall be located to insure maximum travel distance between point of entry to principal spillway inlets so as to prevent short circuiting to the extent possible. See Chapter 19, "Water Management Practices", for procedures for determining or altering sediment basin shape.

#### 3.3.3 Capacity

The minimum size of the principal spillway and drop inlet shall be obtained from Table 3-1; the minimum size of the hooded inlet shall be obtained from Table 3-2; and which principal spillway size shall be based on the total drainage area above the structure. If height of the structure measured from the lowest point of the original ground along the centerline to the crest of the emergency spillway exceeds 15 feet but is less than 35 feet, then the principal spillway shall bypass a minimum design storm of a 5-year, 24-hour duration.

#### 3.3.4 Layout

The principal spillway shall be straight in alignment when viewed in plan. The outlet end must extend to an elevation approximately 6 inches above the stable channel bottom and a minimum of 6 feet beyond the downstream toe of the embankment. An adequate outlet structure such as, but not limited to, rock riprap, concrete or other types of energy dissipaters, as approved by the Director of the Department of Environmental Protection Mining and Reclamation, shall be provided to prevent damage to the toe of the embankment. The minimum slope of the pipe conduit shall be one percent (1%) in order to ensure free drainage.

#### 3.3.5 Pipe Conduits

All types of conduits include steel, wrought-iron, corrugated metal, and aluminum.

##### 3.3.5.1 Corrugated Metal Pipe

## 3.3.5.1.1 Iron or Steel (Zinc-coated):

Zinc-coated (galvanized) corrugated iron or steel culverts shall conform to the requirements of AASHTO M 36 for Type I and Type II culverts, respectively, except modified as follows: Corrugations shall be annular, spiral or a combination of annular and spiral. It shall be close riveted and asphalt coated, which conforms to the requirements of AASHTO M 190, or helical corrugated with welded seam and can be used only where the pH of the normal stream flow, existing and expected, is to be greater than 5.0 during the life of the structure. Where the pH of the normal stream flow, existing and expected, is to be between 3.0 and 5.0, the pipe shall conform to the following requirements:

- A. Type A - Asbestos Bonded Full Bituminous Coated in conformance to AASHTO M 36 and AASHTO M 190, Type A.
- B. Type C - Asbestos Bonded Full Bituminous Coated and paved invert in conformance to AASHTO M 36 and AASHTO M 190, Type C.
- C. Pre-coated or epoxy bonded corrugated steel pipe shall conform to the requirements of AASTO M 245 or other systems of coating approved by the Department of Natural Resources.

Corrugated metal pipe will not be used where the pH is expected to be less than 3.0. The minimum thickness of the pipe shall be 16 gauge for conduits, 18 inches or less in diameter. For larger sizes, the minimum thickness shall be 14 gauge. Bituminous coating damaged by breaks, scuffs, or welding shall be repaired by the application of two coats of hot asphaltic paint or a coating of cold-applied bituminous mastic.

## 3.3.5.1.2 Aluminum:

Corrugated aluminum shall conform to the requirements of AASHTO M 196, Type I and Type II. Helically corrugated aluminum culvert pipe shall conform to the requirements of AASHTO M 211. It can be used only when the normal stream flow, existing and expected, is to be greater than pH 5.0 and less than pH 9.0. The minimum thickness of the pipe shall be 14 gauge.

## 3.3.5.1.3 Joints:

All corrugated metal pipe shall be connected by a watertight flange-type connection or by a watertight connecting band specifically manufactured for a connecting band (band with rod and lugs). The area between the pipe and connecting bands shall be treated with an asphalt cement during installation to assure a watertight joint.

### 3.3.5.2 Steel

Steel pipe may be used where the pH of the normal stream flow during the life of the structure is expected to be 5.0 or greater. It shall be of standard strength and be connected by a watertight mechanical or welded joint.

### 3.3.5.3 Wrought Iron or Cast Iron

Iron pipe may be used under all soil and water conditions. It must be of standard thickness or greater and be connected by a watertight mechanical joint.

## 3.3.6 Drop Inlet

The minimum size and height is given in Table 3-1. In usage of the drop inlet, all the requirements such as base, drainpipe, anti-seep collars, anti-vortex device and trash rack shall be considered in the overall design.

### 3.3.6.1 Base

The riser shall have a base attached with a watertight connection and shall have sufficient weight to prevent floatation of the riser. Two approved bases are: (1) a concrete base 18 inches minimum thickness with the riser imbedded 6 inches in the base. The base should be extended one foot greater than the riser dimensions; (2) a 1/4-inch minimum thickness steel plate welded all around the base of the riser to form a watertight connection. The plate shall be square with each side equal to two times the riser diameter. The plate shall have 2 feet of stone placed on it to prevent floatation.

### 3.3.6.2 Dewatering Device

All structures shall have designed and installed a dewatering device which allows draining of the structure for periodical maintenance and safety.

### 3.3.6.3 Anti-Seep Collars

All conduits through the embankment are to be provided with a minimum of three anti-seep collars, except when the embankment is 5 feet or less. When the embankment is 5 feet or less, two collars will be required. The collars will be at 15 foot intervals with the middle collar at the centerline of the dam. The anti-seep collars shall extend a minimum of 2 feet from the conduit in all directions. The collars and their connections to the pipe shall be watertight.

### 3.3.6.4 Anti-Vortex Device

An anti-vortex device shall be installed on the principal spillway inlet.

1. It shall consist of a thin, vertical plate firmly attached to the top of the riser. The plate dimensions shall be: length + diameter of the riser plus 12 inches; height + 1.5 feet above the crest of the principal spillway; or
2. It shall consist of a horizontal circular plate having a diameter 2 feet greater than the drop inlet and to extend 1.5 feet above the crest of the riser.

#### 3.3.6.5 Trash Racks

A suitable trash rack will be provided where the drainage area will contribute trash to the reservoir.

#### 3.3.7 Hooded Inlet

The minimum size and water level above the inlet (invert of the pipe) is given in Table 3-2. For the same crest elevation, hooded pipes over 24 inches in diameter require a greater depth of water over the inlet to obtain full pipe flow than a pipe drop inlet. In usage of the hooded inlet, the requirements such as drainpipe, anti-seep collars, anti-vortex device and trash rack shall be considered in the overall design.

##### 3.3.7.1 Dewatering Device

All structures shall have designed and installed a dewatering device which is capable of draining the structure for periodical maintenance and safety.

##### 3.3.7.2 Anti-Seep Collars

Minimum requirement for anti-seep collars, see Section 3.3.6.3.

##### 3.3.7.3. Anti-Vortex Devices

An anti-vortex device shall be installed on the hooded inlet. An example of an anti-vortex is shown in Exhibit 3-3.

##### 3.3.7.4 Trash Racks

A suitable trash rack will be provided where the drainage area will contribute trash to the reservoir.

### 3.4 EMERGENCY SPILLWAYS

Emergency spillways are provided to convey large flows safely past an earth embankment. They are usually open channels excavated in earth or rock and/or protected with rock riprap or reinforced concrete.

### 3.4.1 Capacity

The crest elevation of the emergency spillway will be located at a minimum distance of 1.5 feet above the crest elevation of the principal spillway, drop inlet type or a minimum distance of 1.8 times the diameter of pipe above the invert of the pipe of the principal spillway, hooded inlet type. An appropriate combination of principal and emergency spillways shall be designed to safely carry the expected peak rate of discharge from a 25-year, 24-hour frequency storm. The minimum size of the emergency spillway shall at least handle a 10-Year, 24-Hour frequency storm. The expected peak rate of discharge of a storm event shall be obtained from Chapter 2, "Estimating Runoff".

### 3.4.2 Design

The emergency spillway shall be proportioned to pass the peak discharge as determined in Section 2 at a safe velocity determined for the site for the required storm event.

Emergency spillway design to be in accordance with the following references:

1. National Engineering Handbook, Chapter 5, U.S. Department of Agriculture, Natural Resources Conservation Service.
2. Design of Small Dams, U.S. Department of the Interior, Bureau of Reclamation.
3. Erosion and Sediment Control Handbook for Developing Areas West Virginia, U.S. Department of Agriculture, Soil Conservation Service.??????
4. Brater, E. F. and King, H. W., Handbook of Hydraulics, Sixth Edition. Newer edition (8)
5. Gain, E. W., Engineering Field Manual, Natural Resources Conservation Service. and any other standard engineering practices as approved.

The computation shall determine the spillway size, bottom width and  $H_p$ , which is the difference in elevation between the crest of the spillway at the control section to the water surface in the impoundment in feet; velocity in feet per second that will exist in channel below control section at design peak discharge if constructed to slope that is shown; slope in percent allowable for channel below control section; minimum length of channel below control section in feet; and side slope ratio.

### 3.4.3 Layout

The emergency spillway shall be excavated in rock or in earth or protected with rock rip rap, or may be constructed of reinforced concrete. It shall consist of an inlet channel, a control section, and an exit channel. The capacity and design of the emergency spillway shall be as outlined under Sections 3.4.1 and 3.4.2. respectively. The minimum bottom width shall be 10 feet.

The inlet channel shall be level for a minimum distance of 20 feet upstream from the control section if the  $H_p$  in the emergency spillway is equal to or less than 2.5 feet. The level section shall extend 30 feet upstream from the control section if the  $H_p$  exceeds 2.5 feet. The level part of the inlet channel shall be the same width as the exit channel, and its centerline shall be straight and coincident with the centerline of the level section. The level section of the inlet channel shall be located so that the projected centerline of the dam will pass through it. The centerline of the exit channel shall be straight and perpendicular to the control section extending downstream to a point opposite the downstream toe of the dam. Curvature may be introduced below this point if it is certain that the flowing water will not impinge on the embankment should the channel fail at the curve.

The layout will provide that the spillway, when cut around the end of the dam in the abutment, be in a natural ground (cut) to a depth equal to the maximum design flow for at least the level section and the exit channel to a point opposite the downstream toe of the dam. It is preferable that the flow be confined without the use of levees, but where site conditions are such that the exit channel will not contain the design flow, a levee or dike shall be constructed along the exit channel to a height above the exit channel equal to the depth of flow through the spillway at the control section. The levee shall have a minimum top width of 4 feet and side slopes not steeper than 2 horizontal to 1 vertical. The levee shall be constructed in accordance with the requirements for embankment.

The spillway shall be trapezoidal in shape and side slopes shall not be steeper than 1/4 horizontal to 1 vertical in rock or 2 horizontal to 1 vertical in earth.

#### 3.4.4 Permissible Velocities

##### 3.4.4.1 Earth Emergency Spillways

The maximum allowable velocity in the exit channel shall be 6.0 feet per second for earth emergency spillways. This velocity must not be exceeded in the exit channel of the spillway from the control section to a point in the exit channel opposite the downstream toe of the dam or to a point downstream where a channel failure would not cause the flow to impinge on the toe of the dam. All earth spillways shall be seeded and mulched in accordance with Chapter 20 of this handbook for revegetation immediately after construction with the most suitable permanent grass vegetation for the site.

Spillways excavated in earth shall be protected through the level section and the exit channel with durable rock riprap when the exit channel velocity falls between 6.0 feet per second and 12 feet per second. Standards and specifications for rock riprap as outlined in Chapter 19, "Water Management Practices", Section 19.19, shall be adhered to.

##### 3.4.4.2 Rock Emergency Spillways

The maximum allowable velocity shall be 14 feet per second for rock emergency spillways. A spillway shall be classed as a rock emergency spillway when durable

bedrock occurs throughout the level section and in the exit channel to a point opposite the downstream toe of the dam. Durable bedrock is defined as a layer of continuous bedrock equal or greater in thickness than the depth of flow through the spillway at the control section. It shall be proven that the durable bedrock will ensure that small depths of flow in friable, weathering shale will not create down-cutting enough to endanger safe functioning of the spillway.

### 3.4.5 Concrete Emergency Spillways

This standard establishes the minimum acceptable quality for the design and construction of concrete emergency spillways through the embankment when:

- 1.\* The contributing drainage area for the dam does not exceed 200 acres; or
- 2.\* The expected peak discharge does not exceed 660 c.f.s.; or
3. The maximum vertical height of the dam or embankment as measured along the centerline of the embankment to the emergency spillway crest does not exceed 15 feet; or
4. The maximum outlet slope (downstream slope of embankment does not exceed 3 horizontal to 1 vertical; or
5. The sediment control structure is of a temporary nature (life of mining operation only).

\* Items 1 and 2 may be neglected if the structure is an Excavated Sediment Dam with 3 feet or less of water to be impounded against the embankment.

The spillway shall be proportioned in accordance with the table on standard drawing, Exhibit 3-5. In any case, the Q/B ratio shall not exceed 21.0. The spillway shall be constructed as detailed on the standard drawing, Exhibit 3-5. The fill beneath the spillway shall be thoroughly compacted.

## 3.5 EARTH EMBANKMENT

### 3.5.1 Height

The earth embankment shall be high enough to have 1 foot minimum of freeboard between the maximum design flow elevation in the emergency spillway and the top of the dam.

### 3.5.2 Top Width

The minimum top width of earth embankments shall be a minimum of 14 feet when the embankment height is less than 35 feet measured from the upstream toe to the top of the embankment. If the embankment height is greater than 35 feet, the minimum top width of the embankment shall not be less than the quotient of  $(H+35)/5$  where H is the height in feet.

### 3.5.3 Side Slopes

The side slopes of the settled embankment shall be no steeper than 3 horizontal to 1 vertical on the upstream side and 2 horizontal to 1 vertical on the down stream side.

### 3.5.4 Cutoff Trench

The elevation of the top of a compacted cutoff will not be lower than the crest of the principal spillway. The cutoff trench should have a bottom width adequate to accommodate the construction equipment but shall not be less than 8 feet. The trench shall have a minimum side slopes of 1 to 1. The cutoff trench shall be located on the embankment centerline and be of sufficient depth to extend into a relatively impervious layer of soil or to bedrock.

### 3.5.5 Settlement Allowance

The design height of the embankment shall be increased by five percent (5%) to allow for settlement.

### 3.5.6 Utilities Under Embankments

Utilities encountered at dam sites must be relocated away from the site according to the standard criteria and procedure of the utility company involved.

### 3.5.7 Vegetative Protection Against Erosion

The embankment, spillways, borrow area and other disturbed areas shall be mulched and vegetated immediately after construction in accordance with Chapter 20 of this handbook for revegetation.

### 3.5.8 Safety

The embankment, pool area and vegetated spillway shall be fenced as needed to restrict accessibility for reasons of safety. All fences shall be constructed in accordance with good fencing practices. Warning signs of danger shall be installed where deemed necessary.

## 3.6 PLANS, DESIGN DATA AND SPECIFICATIONS

In addition to the "Proposed Drainage Plan", there shall also be submitted the following items concerning sediment dams, embankment type.

1. A "Structure Proportioning Computation Sheet" to be completed for each proposed dam. Exhibit 3-1.
2. Construction plans showing:
  - a. A topographic map on a 1" = 50' scale, with 4-foot contour intervals, showing the reservoir area; embankment; principal spillway; emergency spillway; two permanent

reference points, to include type, elevation and azimuth or bearing between reference points; receiving stream; and north arrow. Topographic map may be mapped using transit stadia survey method but nothing with less accuracy.

- b. A profile view of the embankment along the centerline of the principal spillway showing all pertinent dimensions, elevations, original ground limits and principal spillway design (drawn to scale).
  - c. A profile view of the emergency spillway showing the entrance slope [minimum three percent (3%)], control section and exit channel slope.
  - d. A cross section view drawn to scale of the emergency spillway showing the bottom width, side slopes, height and type of material proposed.
  - e. A cross section view taken along the centerline of the dam drawn to scale showing cutoff trench, original ground limits, unsettled and settled embankment elevations, cleanout elevation, water storage elevation, length of dam, emergency spillway and other pertinent dimensions.
  - f. A cross section view drawn to scale of the entrance channel showing the bottom width, side slopes, height, type of material proposed and profile, if applicable.
3. A "Stage-Area-Storage" computations sheet and "Stage-Area-Storage" curve sheet.
  4. Construction specifications.
  5. Maintenance schedule to include, but not limited to, the following: Procedures for maintenance; method of disposal of sediment; and access to structure for maintenance.
  6. Procedures and timetable for abandonment.

### **3.7 CONSTRUCTION SPECIFICATIONS FOR SEDIMENT DAMS, EMBANKMENT TYPE**

#### **3.7.1 Site Preparation**

The embankment site shall be cleared of all brush, trees, stumps, roots and other undesirable material; all original ground surface slopes are to be no steeper than 1 horizontal to 1 vertical and the entire foundation surface shall be scarified. Sod and topsoil shall be stripped from the embankment site and borrow area and stockpiled for use on the emergency spillway and embankment. Brush, trees, and other undesirable material shall be cleared from the sediment pool area.

#### **3.7.2 Cutoff Trench**

The cutoff trench shall be excavated along the centerline of the embankment. The cutoff trench shall extend into both abutments to an elevation no lower than the crest of the principal spillway. It shall be of sufficient depth to extend into a relatively impervious layer of soil or to bedrock and shall be backfilled with the most impervious material available at the site. The trench shall be kept free of standing water during the backfilling operations. The cutoff trench should have a bottom width adequate to accommodate the construction equipment but shall not be less than 8 feet. The trench shall have minimum side slopes of 1 horizontal to 1 vertical. Compaction requirements shall be the same as those for the embankment.

### 3.7.3 Excavation and Backfill of Stream Channel

Existing stream channels crossing the foundation area shall be deepened and widened as necessary to remove all stones, gravel, sand, stumps, roots and other objectionable material, and to accommodate compaction equipment. Such channels shall then be backfilled with suitable material as specified for earth embankments. The excavated channels shall be kept free of standing water during backfill operation.

### 3.7.4. Pipe Conduit

The pipe conduit shall be placed in a trench excavated in solid undisturbed ground or formed by compacted earth. The conduit shall be imbedded in a formed trench to a depth no less than 1/10 the outside diameter of the pipe. Trench sides shall be sloped back no steeper than 1 horizontal to 1 vertical. Selected impervious backfill material shall be placed around the conduit in 4-inch layers and thoroughly compacted to at least the same density as the adjacent embankment by means of hand tamping or manually directed power tampers or plate vibrators. All pipe joints and anti-seep collar connections to the conduit shall be watertight.

### 3.7.5 Emergency Spillway

The emergency spillway shall conform to the lines, grades, bottom width and side slopes as shown on the plans.

### 3.7.6 Borrow Areas

All borrow excavation will have side slopes no steeper than 2 horizontal to 1 vertical and shall be graded and left in such a manner as to provide suitable drainage.

### 3.7.7 Selection and Placement of Embankment Materials

The most impervious material shall be used in the cutoff trench and center portion of the dam. When sandy or gravelly material is encountered, it should be placed in the outer shell preferably in the downstream portion of the dam. The distribution and gradation of material throughout the fill shall be such that there will be no lenses, pockets, streaks, or layers of material differing substantially in texture or gradation from the surrounding material. Where it is necessary to use materials of varying texture and gradation, the more impervious material shall be placed in the upstream and center portions of the dam. Very dry or wet material shall not be used. The fill material shall be free of all sod, roots, stones over 6 inches in diameter and other objectionable material such as large vegetative materials, frozen soil, or coal processing wastes. The moisture content of the material should be such that when kneaded in the hand, it will just form a ball that will not readily separate.

The embankment shall be brought up on uniform 6-8 inch layers of approximate uniform elevation over its entire area. Each layer shall be thoroughly compacted by making at least 4 complete passes with a tamping roller or by applying equal compactive effort with rubber tired equipment.

If the height of the structure, measured from the lowest point of the original ground along the centerline to the crest of the emergency spillway, exceeds 15 feet, the embankment shall be brought up on uniform 6-8 inch layers of approximate uniform elevation over its entire area. Each layer shall be thoroughly compacted to achieve ninety percent (90%) standard proctor dry density utilizing sheeps foot roller, tamping roller or other approved compaction equipment.

### 3.7.8 Protection Against Erosion

The earth embankment, spillways and borrow areas above the sediment pool shall be seeded and mulched immediately after construction in accordance with Chapter 20 of this handbook for revegetation.

**EXHIBIT 3-1**

**SEDIMENT DAMS, EMBANKMENT TYPE**

**Structure Proportioning Computation Sheet**

Dam Number \_\_\_\_\_

**SEDIMENT STORAGE REQUIREMENTS**

Drainage Area = \_\_\_\_\_ Ac.

Area Disturbed = \_\_\_\_\_ Ac.

Sediment Volume = 0.125 Ac. Ft./Acre Times Disturbed Area Controlled  
by Dam Number \_\_\_\_\_ = \_\_\_\_\_ Ac. Ft.

Sediment Pool Elevation = \_\_\_\_\_ = Principal Spillway Crest

**PRINCIPAL SPILLWAY AND DROP INLET DESIGN, IF APPLICABLE**

**Principal Spillway Design**

Principal Spillway Diameter = \_\_\_\_\_ In.

Type \_\_\_\_\_ pH \_\_\_\_\_

Principal Spillway Length \_\_\_\_\_ Ft.

Principal Spillway Slope \_\_\_\_\_ %

Drop Inlet

Type Base \_\_\_\_\_ pH \_\_\_\_\_  
 Type Base \_\_\_\_\_  
 Dimension of Riser \_\_\_\_\_ In. Diameter  
 Height of Riser = \_\_\_\_\_ Ft.  
 Perforated \_\_\_\_\_ Yes \_\_\_\_\_ No

Hooded Inlet, If Applicable

Pipe Conduit Diameter = \_\_\_\_\_ In.  
 Type \_\_\_\_\_ pH \_\_\_\_\_  
 Hooded Inlet Length \_\_\_\_\_ Ft.  
 Hooded Inlet Slope \_\_\_\_\_ %  
 Minimum Freeboard Above Invert of Pipe = \_\_\_\_\_ In.

EMERGENCY SPILLWAY DESIGN

Emergency Spillway Elevation ( \_\_\_\_\_ ) = Principal Spillway  
 Elevation ( \_\_\_\_\_ ) = Minimum Freeboard ( \_\_\_\_\_ Ft.)  
 Peak Discharge (Exhibit 2-7) = \_\_\_\_\_ cfs  
 Emergency Spillway Proportions  
 Bottom Width, b = \_\_\_\_\_ Ft.  
 Emergency Spillway Stage, Hp = \_\_\_\_\_ Ft.  
 Velocity, V = \_\_\_\_\_ fps  
 Slope of Channel Below Control Section, S = \_\_\_\_\_ %  
 Minimum Length of Channel Below Control Section, X = \_\_\_\_\_ Ft.  
 Side Slopes \_\_\_\_\_ Horizontal to \_\_\_\_\_ Vertical  
 Spillway Material \_\_\_\_\_  
 Allowable Velocity \_\_\_\_\_ fps  
 Top of Embankment Elevation [Constructed] ( \_\_\_\_\_ ) = Emergency  
 Spillway Elevation ( \_\_\_\_\_ ) + Emergency  
 Spillway Stage, Hp ( \_\_\_\_\_ Ft.) + Freeboard  
 (Minimum 1 Ft.)

DISCHARGE SUMMATIONS

Principal Spillway Discharge ( \_\_\_\_\_ ) + Emergency Spillway  
Discharge ( \_\_\_\_\_ ) = Peak Discharge of a 25-year, 24-hour storm  
Event ( \_\_\_\_\_ )

## ANTI-VORTEX - TRASH AND SAFETY GUARD

Drill Holes and  
Space Angles Opposite  
each other

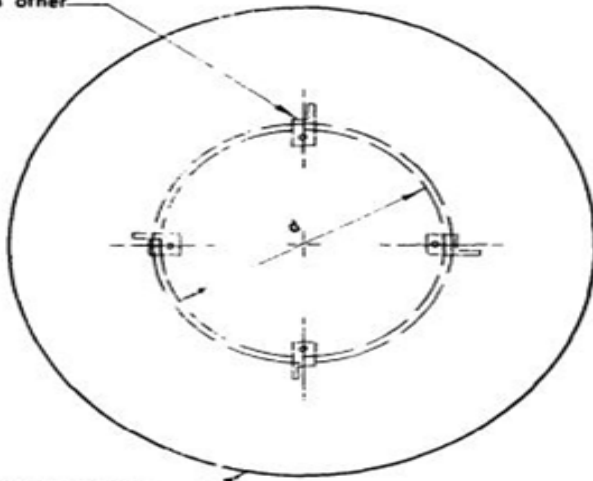

Round or Square  
Plate may be used

**PLAN**

4 - 1/2" x 2" Bolt  
Nut & Washer  
Weld Nut to Bottom  
Side of Angle Iron

Fillet Weld 2" x 2" x 2" x 1/4"  
Angle Iron to Vertical  
" x " Angle Iron.

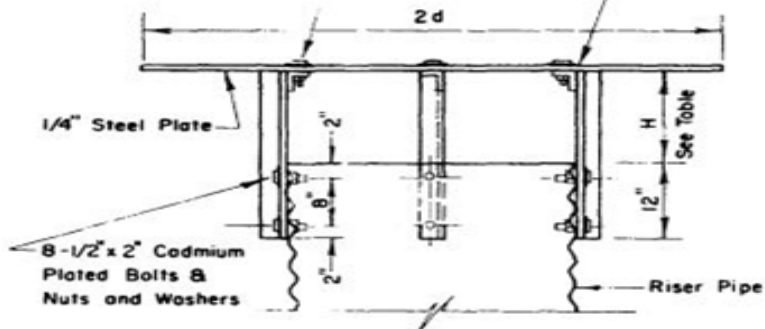

**SECTION AT CENTER**

Inlet d Dia. inches	Barrel Dia. inches	H inches
12	6	6
12	8	6
15	10	6
15	12	7
18	12	6
24	15	7 1/2
24	18	10
* 30	18	8 1/2
* 30	24	13 1/2
* 36	24	12

\* Use Angle Iron Stiffeners on Plate  
as Specified.

## DROP INLET

EXHIBIT 3-2

METAL BAFFLE SHALL HAVE THE SAME COATING AS THE PIPE TO WHICH IT IS ATTACHED. WHERE METAL BAFFLE IS FABRICATED OF MORE THAN ONE PIECE OF METAL, THE SEPERATE PIECES SHALL SECURELY FASTENED TO EACH OTHER. SHARP CORNERS SHALL REMOVED. METAL BAFFLE MAY BE MADE OF CORRUGATED OR SMOOTH SHEET METAL AND SHAPED CIRCULAR, SQUARE OR AS SHOWN.

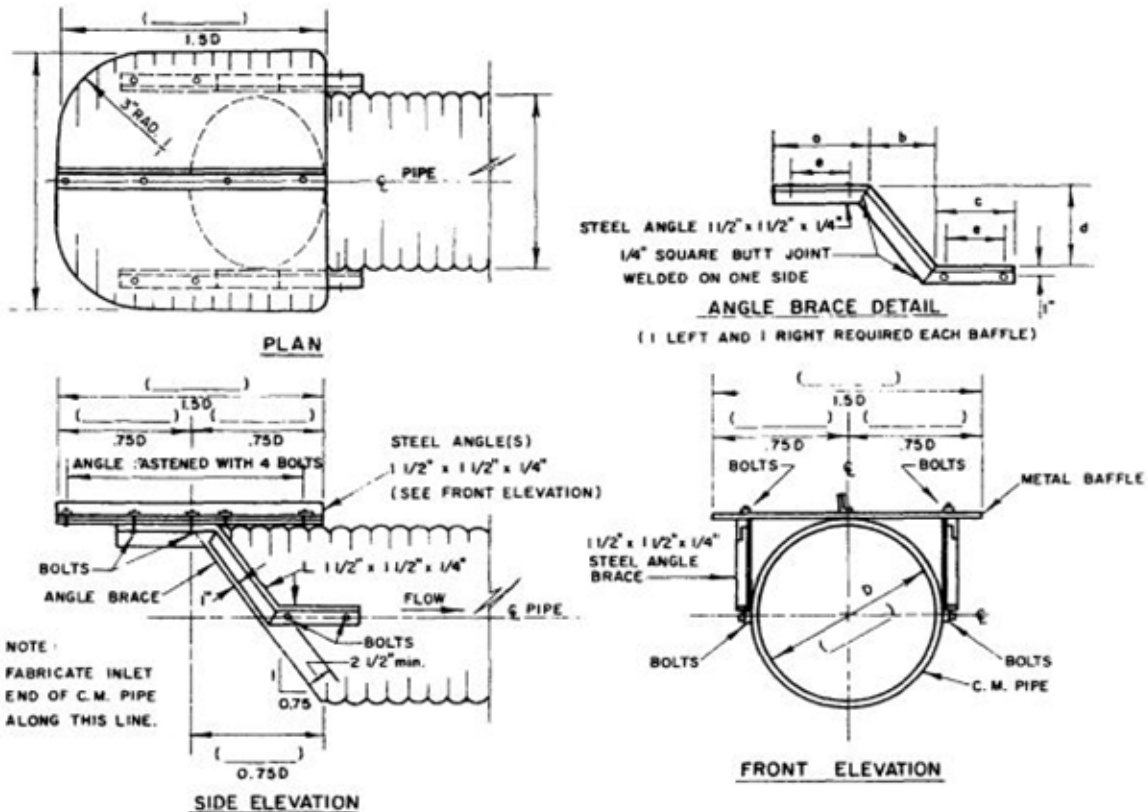

- NOTES:
- ALL BOLTS SHALL BE 3/8" x 1 1/2" w/NUT AND SPLIT WASHERS.
  - ALL HOLES FOR BOLTS SHALL BE DRILLED 7/16" DIA.
  - ALL NUTS, BOLTS AND WASHERS SHALL BE GALVANIZED, CADMIUM PLATED, OR STAINLESS STEEL.
  - ALL CUTS SHALL BE SAW OR SHEAR CUTS.
  - HOLES IN ANGLE BRACE SHALL BE SPACED AND LOCATED TO MATCH CORRUGATIONS IN PIPE AND BAFFLE.
  - STEEL ANGLES SHALL BE GALVANIZED.
  - ALL GALVANIZING DAMAGED BY CUTTING, DRILLING OR WELDING SHALL BE REPAIRED BY PAINTING WITH TWO (2) COATS OF ZINC DUST-ZINC OXIDE PRIMER.

## HOOD INLET WITH BAFFLE CORRUGATED METAL

EXHIBIT 3-3

### CONCRETE EMERGENCY SPILLWAY

EXHIBIT 3-5

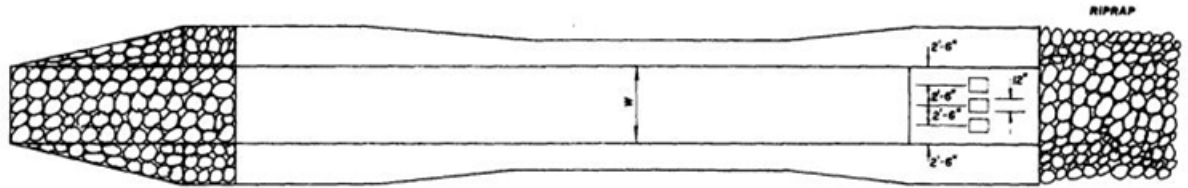

PLAN VIEW

RIPRAP GRADED FROM 1' TO 3' CONCRETE TO BE REINFORCED WITH 6x6x2 1/2 WELDED WIRE MESH FABRIC OR NO. 3 BARS - 12" CENTERS BOTH DIRECTIONS.

W-FT	Q-CFS
5	110
10	220
15	330
20	440
25	550
30	660

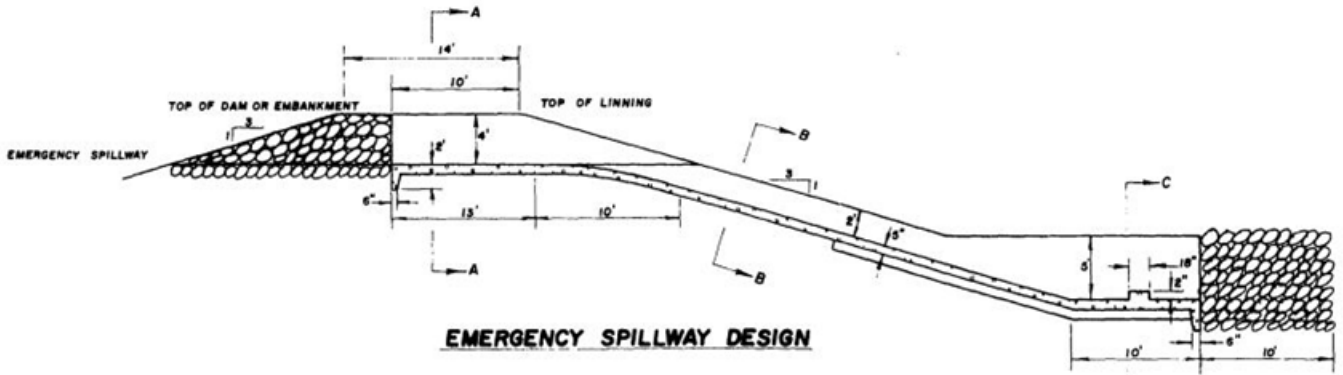

EMERGENCY SPILLWAY DESIGN

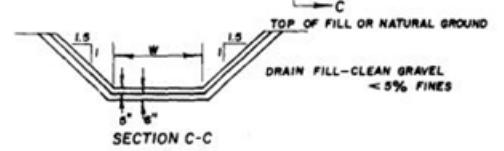
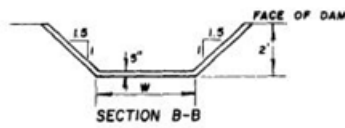
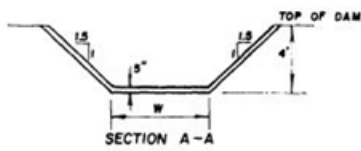

CHART NO. 3-1

PRINCIPAL SPILLWAY

Drainage Area (Acres)	Effective Height* (Feet)	Minimum Design Storm
200 to 500	15 or Less	5 Year, 24 Hour
	More Than 15 Through 20	10 Year, 24 Hour
	More Than 20 Through 35	25 Year, 24 Hour

CHART NO. 3-2

EMERGENCY SPILLWAY

Drainage Area (Acres)	Effective Height* (Feet)	Minimum Design Storm		Freeboard (Feet)
		Frequency (Yrs.)	Duration (Hrs)	
200 to 500	35 or Less	50	24	2.0

\*Effective Height is the difference in elevation (feet) between the low point of the original ground along the centerline of the structure to the crest of the Emergency Spillway.

TABLE 3-1

MINIMUM REQUIRED PRINCIPAL SPILLWAY AND DROP INLET SIZE

Drainage Area	Pipe Conduit Diameter	Drop Inlet Diameter	Square Drop Inlet Dimensions (Ft.)	Minimum Drop Inlet Height (Ft.)
0 - 49	12	18	2 x 2	2.5
50 - 74	15	24	2 x 2	2.5
75 - 99	18	30	2 x 2	3.0
100 - 149	24	36	2.5 x 2.5	4.0
150 - 200	30	42	3 x 3	5.0

TABLE 3-2

MINIMUM REQUIRED HOODED INLET SIZE

Drainage Area (Ac.)	Pipe Conduit Diameter (In.)	Minimum Freeboard Above The Invert of The Pipe (In.)
0 - 29	10	18
30 - 49	12	21.6
50 - 74	15	27
75 - 99	18	32.4
100 - 149	24	43.2
150 - 200	30	54.-

# 4 *Excavated Sediment Dam*

## *– Embankment Type*

### **CONTENTS**

Definitions	1
Scope	1
Location	2
Sediment Dam Dimensions	2
Entrance Channel	2
Emergency Spillway	2
	<i>Capacity</i> 2
	<i>Design</i> 3
	<i>Layout</i> 3
	<i>Permissible Velocities</i> 3
	<i>Concrete Emergence Spillway</i> 3
Earth Embankment	4
	<i>Height</i> 4
	<i>Top Width</i> 4
	<i>Side Slopes</i> 4
	<i>Cutoff Trench</i> 4
	<i>Settlement Allowance</i> 4
	<i>Utilities Under Embankments</i> 4
	<i>Disposal of Waste Material</i> 4
	<i>Safety</i> 5
	<i>Vegetative Protection Against Erosion</i> 5
Principal Spillways	5
Plans, Design Data and Specifications	5
Construction Specifications	6
	<i>Site Preparation</i> 6
	<i>Excavation</i> 6
	<i>Selection and Placement of Embankment Materials</i> 7
	<i>Vegetative Protection Against Erosion</i> 7
	<i>Erosion and Pollution Control</i> 7

## EXCAVATED SEDIMENT DAM, EMBANKMENT TYPE

### 4.1 DEFINITION

A water impoundment constructed by excavating a pit or "dugout" which utilizes an earth embankment to increase the storage potential of the structure to a maximum of 3 feet of water impounded against the earth embankment at normal pool elevation. The pool elevation is defined as the crest of the principal spillway and/or the crest of the emergency spillway. Consideration will be given to an increase in embankment height, a maximum of 5' of water impounded against the embankment at normal pool, if design of spillway is based on a 50-year, 24-hour frequency storm.

### 4.2 SCOPE

This chapter establishes the minimum acceptable quality for the design and construction of excavated sediment dams, embankment type, in predominantly rural or agricultural areas in West Virginia, when:

1. The contributing watershed does not exceed 500 acres.
2. The vertical distance between the upstream toe of the embankment and the crest of the emergency spillway does exceed 5 feet in height and does not have a storage volume greater than 20 acre-feet as measured at normal pool elevation. Also, does not present a hazard to coal miners as determined by the Mine Safety and Health Administration. Structures which exceed the conditions outlined in Section 4.2(2) shall comply with the following minimum standards;
  - a. An appropriate combination of principal and emergency spillways shall be provided to discharge safely the runoff resulting from a 100-year, 24-hour precipitation event or a large event specified by the Department of Environmental Protection Mining and Reclamation.
  - b. The embankment shall be designed and constructed with a static safety factor of at least 1.5 or a higher safety factor as designed by the Department of Environmental Protection Mining and Reclamation to ensure stability.
  - c. Appropriate barriers shall be provided to control seepage along the conduits that extend through the embankment.
  - d. The criteria of the Mine Safety and Health Administration published in 30 C.F.R. 77.216 shall be adhered to. All inspection reports and approvals shall be provided to the Director of the Department of Environmental Protection Mining and Reclamation.
3. Failure of the structure would not result in loss of life; in damage to homes, commercial or industrial buildings, main highways, or railroads; or in interruption of the use or service of public utilities.

### 4.3 LOCATION

Excavation sediment dams fed by surface runoff may be located on almost any type of topography; however, they are most satisfactory in areas with relatively flat terrain. An excavated sediment dam may be located in a natural or constructed drainway or preferably to one side of a natural or constructed drainway if the runoff can be directed into the structure.

### 4.4 SEDIMENT DAM DIMENSIONS

Excavated sediment dams, embankment type, may be constructed to any desired shape that will meet sediment storage capacity requirements. The width and depth of excavated sediment dams are not limited.

Side slopes of excavated sediment dams shall be such that they will be stable and shall not be steeper than 2 horizontal to 1 vertical in earth and 1/4 horizontal to 1 vertical in rock.

### 4.5 ENTRANCE CHANNEL

The entrance channel shall not exceed 2 horizontal to 1 vertical in earth and 1 horizontal to 1 vertical in rock, and extend from the bottom of the excavated sediment dam upstream to the original stream bed. The entrance channel shall be protected with rock riprap in accordance with the standard specifications for rock riprap as outlined in Chapter 19, "Water Management Practices", Section 19.19. Minimum side slopes shall be 2 horizontal to 1 vertical and shall also be protected with rock riprap for a vertical height of 2 feet.

The minimum bottom width of the entrance channel shall be 5 feet and shall never have a width less than that of the natural channel.

### 4.6 EMERGENCY SPILLWAY

An earth embankment shall be used to increase the capacity of the excavated sediment dam provided that the depth of water impounded against any embankment at normal pool elevation is less than 3 feet. All excavated sediment dams will be required to have an emergency spillway to convey normal and large flows safely past the embankment. They are usually open channels either excavated in earth, rock or constructed over the constructed embankment and/or protected with rock riprap or reinforced concrete.

#### 4.6.1 Capacity

An appropriate combination of principal spillway, if applicable, and emergency spillway shall be designed to safely carry the expected peak rate of discharge from a 25-year, 24-hour frequency storm. The minimum size of the emergency spillway shall at least handle a 10-year, 24-hour frequency storm if a principal spillway is utilized in combination.

#### 4.6.2 Design

The design of the emergency spillway shall conform to that given under Chapter 3, "Sediment Dams, Embankment Type, Section 3.4.2

The emergency spillway or principal spillway, if applicable, should be located to ensure maximum flow path from the inlet to the outlet so as to prevent short-circuiting to the extent possible. See Chapter 19, "Water Management Practices", for procedures for determining or altering sediment basin shape.

#### 4.6.3 Layout

The emergency spillway shall be either excavated in earth, rock or constructed over the constructed embankment and protected rock riprap or may be constructed of reinforced concrete. It shall consist of an inlet channel, a control section, and a exit channel. The capacity and design of the emergency spillway shall be as outlined under Sections 4.6.1 and 4.6.2, respectively. The minimum bottom width shall be 10 feet.

The inlet channel shall be level for a minimum distance of 20 feet from the control section of the Hp when the emergency spillway is equal to or less than 2.5 feet. The level section shall extend 30 feet upstream from the control section if the Hp exceeds 2.5 feet. The level part of the inlet channel shall be the same width as the exit channel, and its centerline shall be straight and coincide with the centerline of the level section. The level section of the inlet channel shall be located so that the projected centerline of the dam will pass through it.

The centerline of the exit channel shall be straight and perpendicular to the control section extending downstream to a point opposite the downstream toe of the dam. Curvature may be introduced below this point if it is certain that the flowing water will not impinge on the embankment should the channel fail at the curve.

The spillway shall be trapezoidal in shape and the side slope shall not be steeper than 1/4 horizontal to 1 vertical in rock or 2 horizontal to 1 vertical in earth.

#### 4.6.4 Permissible Velocities

Permissible velocities for earth, rock riprap or rock emergency spillway shall be in accordance with Chapter 3, "Sediment Dams, Embankment Type", Sections 3.4.4.1 and 3.4.4.2, respectively.

#### 4.6.5 Concrete Emergence Spillway

Minimum concrete emergence spillway plans, design data and specifications shall be in accordance to Chapter 3, "Sediment Dams, Embankment Type", Section 3.4.5.

## 4.7 EARTH EMBANKMENT

### 4.7.1 Height

The earth embankment shall be high enough to have 1 foot minimum of freeboard between the maximum design flow elevation in the emergency spillway and the top of the embankment.

### 4.7.2 Top Width

The top width of earth embankments shall be a minimum of 14 feet.

### 4.7.3 Side Slopes

The side slopes of the settled embankment shall be no steeper than 3 horizontal to 1 vertical on the upstream side and 2 horizontal and 1 vertical on the downstream side.

### 4.7.4 Cutoff Trench

A cutoff trench may be required depending on specific site conditions.

### 4.7.5 Settlement Allowance

The design height of the embankment shall be increased by ten percent (10%) to allow for settlement.

### 4.7.6 Utilities Under Embankments

Utilities encountered at embankment sites must be relocated away from the site according to the standard criteria and procedure of the utility company involved.

### 4.7.7 Disposal of Waste Material

The waste material from the excavated sediment dam may be spread, used in the embankment or removed from the site as conditions warrant.

The waste material, when not removed from the site, shall be placed in a manner that its weight will not endanger the stability of the pond side slopes and rainfall will not wash the material back into the pond. Not less than 12 feet should be left between the toe of the waste material and the edge of the pond.

If the waste material is spread, it should be to a height of no more than 3 feet with the surface graded to a uniform slope away from the pond. The pond side slope of the spread material should be no steeper than 2 horizontal to 1 vertical.

If the waste material is to be used in an embankment, it shall be free of all sod, roots, stones over 6 inches in diameter, and other objectionable material.

#### 4.7.8 Safety

The embankment, pool area and emergence spillway shall be fenced as needed to restrict accessibility for reasons of safety. All fences shall be constructed in accordance with good fencing practices. Warning signs of danger shall be installed where deemed necessary.

#### 4.7.9 Vegetative Protection Against Erosion

The waste material, spillway, embankment and any other areas disturbed during construction shall be mulched and vegetated immediately upon completion of the pond in accordance with Chapter 20 of this handbook for revegetation.

### 4.8 PRINCIPAL SPILLWAYS

**Principal spillways may** be utilized on excavated sediment dams for the purpose of having a dewatering device installed to assist the structure in erosion and sediment control, to provide additional flood protection or to reduce the frequency of operation of the emergence spillway so as to possibly utilize a vegetated earth spillway.

Chapter 3, "Sediment Dams, Embankment Type," Section 3.3 will be adhered to in incorporating principal spillways for excavated sediment dams.

If principal spillways are utilized, then additional requirements for emergency spillways shall be required, such as the following:

The crest elevation of the emergency spillway will be located at a minimum distance of 1.5 feet above the crest elevation of the principal spillway, drop inlet type, or a minimum distance of 1.8 times the diameter of pipe above the invert of the pipe of the principal spillway, hooded inlet type.

### 4.9 PLANS, DESIGN DATA AND SPECIFICATIONS

In addition to "The Drainage Plan" there shall also be submitted the following items concerning excavated sediment dams, embankment type:

1. A "Structure Proportioning Computation Sheet" to be completed for each excavated sediment dam. Exhibit 4-1.
2. Construction plans showing a plan-view drawn to scale, with plan-view indicating the following: entrance channel; emergency spillway; bottom limits and dimensions; top of pool elevation limits and dimensions; embankments; two permanent reference points to include type, elevation and azimuth or bearing between points; location of centerline profile and location of 50 foot stations on centerline profile.

3. A centerline profile drawn to scale indicating the following: original ground limits; proposed finished limits such as side slopes, water depth, cleanout elevation, water surface elevation, embankment details and 50 foot stations.
4. Cross sections plotted at 50 foot intervals from the centerline profile and drawn to scale with section to indicate the following: original ground limits, proposed finished limits, side slopes, water depth, water surface elevation, embankment details and other pertinent information.
5. Cross section of entrance channel and entrance channel profile, all drawn to scale and showing all pertinent information.
6. Cross section of emergency spillway drawn to scale and the emergence spillway profile showing all pertinent information.
7. If applicable, Principal Spillway Plans, design data and specifications as outlined in Chapter 3, "Sediment Dams, Embankment Type", Section 3.6.
8. Maintenance schedule to include, but not limited to, the following: Procedures for maintenance, method of disposal of sediment and access to structure for maintenance.
9. Construction specifications.
10. Procedures and timetable for abandonment.

#### **4.10 CONSTRUCTION SPECIFICATIONS**

##### **4.10.1 Site Preparation**

The pond site and waste areas shall first be cleared of all woody vegetation. The limits of the excavation and spoil placement areas shall be staked, and the depth of cut from the ground surface to the pond bottom should be indicated on the stakes.

If an embankment is to be constructed, the embankment site shall be cleared of all brush, trees, stumps, roots and other undesirable material. All original ground surface slopes are to be no steeper than 1 horizontal to 1 vertical and the entire foundation surface shall be scarified. Sod and topsoil shall be stripped from the embankment site.

##### **4.10.2 Excavation**

Excavation and placement of the waste material shall be done as near to the staked lines and grades as skillful operation of the equipment will permit. Side slopes of the excavated pond will be no steeper than 2 horizontal to 1 vertical in earth and 1/4 horizontal to 1 vertical to rock.

#### 4.10.3 Selection and Placement of Embankment Materials

If an embankment is constructed, the most impervious material will be used in the center portion. When sandy or gravelly material is encountered, it shall be placed in the outer shell, preferably in the downstream portion of the embankment. The fill material shall be taken from approved designated borrow areas. It shall be free of roots, woody vegetation, oversized stones, rocks, or other objectionable material.

Areas on which fill is to be placed shall be scarified prior to placement of fill. The fill material should contain sufficient moisture so that it can be formed into a ball without crumbling. If water can be squeezed out of the ball, it is too wet for proper compaction.

Fill material will be placed in 6-8 inch layers and shall be continuous over the entire length of the fill. Compaction will be obtained by routing the hauling equipment over the fill so that the entire surface of the fill is traversed by at least one tread track of the equipment, or compaction shall be achieved by the use of a compactor. The embankment shall be constructed to an elevation of ten percent (10%) higher than the design height to allow for settlement if compaction is obtained with hauling equipment. If compactors are used for compaction, the overbuild may be reduced to five percent (5%).

#### 4.10.4 Vegetative Protection Against Erosion

The waste material, spillway, embankment and any other area disturbed during construction shall be mulched and vegetated immediately upon completion of the pond in accordance with Chapter 20 of this handbook for revegetation.

#### 4.10.5 Erosion and Pollution Control

Construction operations will be carried out in such a manner that erosion and water pollution will be minimized. State and local laws concerning pollution abatement shall be complied with.

# 5 *Excavated Sediment Pond, Dugout Type*

## **CONTENTS**

Definitions	1
Scope	1
Location	1
Sediment Pond Dimensions	1
Entrance Channel	1
Exit Channel	1
Embankments	2
Disposal of Waste Material	2
Safety	2
Vegetative Protection Against Erosion	2
Plans, Design Data and Specifications	2
Construction Specifications	3
<i>Site Preparation</i>	3
<i>Excavation</i>	3
<i>Selection and Placement of Embankment Material</i>	3
<i>Vegetative Protection against Erosion</i>	4
<i>Erosion and Pollution Control</i>	4
Exhibit 5-1	5

## **EXCAVATED SEDIMENT POND, DUGOUT TYPE**

### **5.1 DEFINITION**

A water impoundment made by excavating a pit or "dugout". At normal pool elevation, there will be no water impounded against fill material or embankment. Normal pool elevation is defined as the elevation of the crest of exit channel.

### **5.2 SCOPE**

This chapter establishes the minimum acceptable quality for the design and construction of excavated sediment ponds in predominantly rural or agricultural areas in West Virginia, when the contributing watershed does not exceed 500 acres.

### **5.3 LOCATION**

Excavated sediment ponds fed by surface runoff may be located on almost any type of topography; however, they are most satisfactory in areas with relatively flat terrain. An excavated pond may be located in a natural or constructed drainway or preferably to one side of a natural or constructed drainway if the runoff can be directed into the pond.

### **5.4 SEDIMENT POND DIMENSIONS**

Excavated sediment ponds may be constructed to any desired shape that will meet sediment capacity requirements. The width and depth of sediment ponds are not limited.

Side slopes of excavated sediment ponds shall be such that they will be stable and shall not be steeper than 2 horizontal to 1 vertical in earth and 1/4 horizontal to 1 vertical in rock.

### **5.5 ENTRANCE CHANNEL**

The entrance channel profile shall not exceed 2 horizontal to 1 vertical in earth and 1 horizontal to 1 vertical in rock, extended from the bottom of the excavated sediment pond upstream to the original stream bed. The entrance channel shall be protected with a rock riprap in accordance with the standard specifications for rock riprap as outlined in Chapter 19, "Water Management Practices", Section 19.19. Minimum side slopes shall be 2 horizontal to 1 vertical and shall also be protected with rock riprap for a vertical height of 2 feet.

The minimum bottom width of the entrance channel shall be 5 feet and shall never have a width less than that of the natural channel.

### **5.6 EXIT CHANNEL**

Pipe principal spillways shall not be required for excavated sediment ponds. The exit channel shall be protected with rock riprap in accordance to standards and specifications for rock riprap as outlined in Chapter 19, "Water Management Practices".

The exit channel should be located to ensure maximum travel distance between point of entry to exit channel so as to prevent short-circuiting to the extent possible, see Chapter 19, "Water Management Practices" for procedures for determining or altering sediment basin shape.

The minimum width of exit channels shall be 10 feet but shall never have a width less than that of the natural stream channel. Minimum side slopes shall be 2 horizontal to 1 vertical and shall also be protected with rock riprap for vertical height of 2 feet.

### **5.7 EMBANKMENTS**

An embankment may be used only to assist in bypassing any runoff through an exit channel; at normal water pool elevation there will be water impounded against the embankment.

The minimum top width shall be 14 feet and have side slopes no steeper than 2 horizontal to 1 vertical on the upstream and downstream slope. A cutoff trench will not be required.

### **5.8 DISPOSAL OF WASTE MATERIAL**

The waste material from the excavated sediment pond may be spread, used in the embankment or removed from the site as conditions warrant.

The waste material, when not removed from the site, shall be placed in a manner that its weight will not endanger the stability of the pond side slopes and the rainfall will not wash the material back into the pond. Not less than 12 feet should be left between the toe of the waste material and the edge of the pond.

If the waste material is spread, it should be to a height of no more than 3 feet with the surface graded to a uniform slope away from the pond. The pond side slope of the spread material should be no steeper than 2 horizontal to 1 vertical.

If the waste material is to be used in an embankment, it shall be free of all sod, roots, stones over 6 inches in diameter, and other objectionable material.

### **5.9 SAFETY**

The embankment, pool area and exit channel shall be fenced as needed to restrict accessibility for reasons of safety. All fences shall be constructed in accordance with good fencing practices. Warning signs of danger shall be installed where deemed necessary.

### **5.10 VEGETATIVE PROTECTION AGAINST EROSION**

The waste material, exit channel, embankment and any other area disturbed during construction shall be mulched and vegetated immediately upon completion of the pond in accordance with Chapter 20 of this handbook for revegetation.

### **5.11 PLANS, DESIGN DATA AND SPECIFICATIONS**

In addition to "The Drainage Plan", there shall also be submitted the following items concerning excavated sediment ponds, dugout type:

1. A "Structure Proportioning Computation Sheet" is to be completed for each excavated sediment pond. Exhibit 5-1.
2. Construction plans showing a plan-view indicating the following: entrance channel; exit channel; bottom limits and dimensions; top of pool elevation limits and dimensions; embankments; two permanent

reference points to include type, elevation and azimuth or bearing between points; location of centerline profile and location of 50 foot stations on the centerline profile.

3. A centerline profile drawn to scale indicating the following: original ground limits; proposed finished limits such as, side slopes, water depth, cleanout elevation, water surface elevation, embankment details and 50 foot stations.
4. Cross sections plotted at 50 foot intervals from the centerline profile and drawn to scale with section to indicate the following: original ground limits, proposed finished limits, side slopes, water depth, water surface elevation, embankment details and other pertinent information.
5. Cross section of entrance channel and entrance channel profile, all drawn to scale and showing all pertinent information.
6. Cross section of exit channel drawn to scale showing all pertinent information.
7. Maintenance schedule to include, but not limited to, the following:  
Procedures for maintenance, method of disposal of sediment and access to structure for maintenance.
8. Construction specifications.
9. Procedures and timetable for abandonment.

## 5.12 CONSTRUCTION SPECIFICATIONS

### 5.12.1 Site Preparation

The pond site and waste areas shall first be cleared of all woody vegetation. The limits of the excavation and spoil placement areas shall be staked, and the depth of cut from the ground surface to the pond bottom should be indicated on the stakes.

If an embankment is to be constructed, the embankment site shall be cleared of all brush, trees, stumps, roots and other undesirable material. Sod and topsoil shall be stripped from the embankment site.

### 5.12.2 Excavation

Excavation and placement of the waste material shall be done as near to the staked lines and grades as skillful operation of the equipment will permit. Side slopes of the excavated pond will be no steeper than 2 horizontal to 1 vertical in earth and 1/4 horizontal to 1 vertical to rock.

### 5.12.3 Selection and Placement of Embankment Material

If an embankment is constructed, the most impervious material will be used in the center portion. When sandy or gravelly material is encountered, it shall be placed in the outer shell, preferably in the downstream portion of the embankment. The fill material shall be taken from approved designated borrow areas. It shall be free of roots, woody vegetation, oversized stones, rocks, or other objectionable material.

Areas on which fill is to be placed shall be scarified prior to placement of fill. The fill material should contain sufficient moisture so that it can be formed into a ball without crumbling. If water can be squeezed out of the ball, it is too wet for proper compaction.

Fill material will be placed in 6-8 layers and shall be continuous over the entire length of the fill. Compaction will be obtained by routing the hauling equipment over the fill so that the entire surface of the fill is traversed by at least one tread track of the equipment, or compaction shall be achieved by the use of a compactor. The embankment shall be constructed to an elevation ten percent (10%) higher than the design height to allow for settlement if compaction is obtained with hauling equipment. If compactors are used for compaction, the overbuild may be reduced to five percent (5%).

#### 5.12.4 Vegetative Protection against Erosion

The waste material, spillway, embankment and any other area disturbed during construction shall be mulched and vegetated immediately upon completion of the pond in accordance with Chapter 20 of this handbook for revegetation. (This is a repeat from 5.10)

#### 5.13.5 Erosion and Pollution Control

Construction operations will be carried out in such a manner that erosion and water pollution will be minimized. State and local laws concerning pollution abatement shall be complied with.

Exhibit 5-1

EXCAVATED SEDIMENT POND, DUGOUT TYPE  
Structure Proportioning Computation Sheet

Pond Number \_\_\_\_\_

SEDIMENT STORAGE REQUIREMENT

Drainage Area = \_\_\_\_\_ Ac.

Area Disturbed = \_\_\_\_\_ Ac.

Sediment Volume = 0.125 Ac. Ft./Acre Times Disturbed Area Controlled by

Pond Number \_\_\_\_\_ = \_\_\_\_\_ Ac.Ft.

Sediment Pool Elevation = \_\_\_\_\_

Top of Embankment Settled Elevation \_\_\_\_\_ = Sediment Pool

Elevation \_\_\_\_\_ + 2.0 Ft. or Height of Exit

Channel \_\_\_\_\_ Ft.

SEDIMENT POND DIMENSIONS AND VOLUME DETERMINATION

NOTE: If pond is to be regular shape and constructed on relatively flat terrain.

Bottom Length = \_\_\_\_\_ Ft.

Bottom Width = \_\_\_\_\_ Ft.

Water Depth = \_\_\_\_\_ Ft.

Side Slopes = \_\_\_\_\_ Horizontal to \_\_\_\_\_ Vertical

Volume = \_\_\_\_\_ Cubic Ft. = \_\_\_\_\_ Ac.Ft.  
(1 Ac. Ft. = 43,560 Cubic Ft.)

NOTE: If pond is to be irregular shape and constructed on relatively flat terrain, complete a Storage-Stage Computation Sheet and Storage-Stage Curve as shown in Chapter 3.

# 6

## *Gabion Sediment Dam*

### **C O N T E N T S**

Definitions	1	
Scope	1	
Emergency Spillway	2	
Gabion Cross-Section	2	
Key-In of Foundation	2	
Filling and Binding Gabion Wire Baskets	3	
Material Specifications	3	
Plans, Design Data and Specifications	3	
Construction Specifications	4	
	<i>Site Preparation</i>	4
	<i>Preparation of Foundation</i>	4
	<i>Fill and Binding</i>	4
	<i>Backfilling Upstream Face</i>	5
	<i>Spillway</i>	5
	<i>Downstream Channel Protection</i>	5
	<i>Vegetative Protection Against Erosion</i>	5
Exhibit 6-1		6
Table 6-1		7
Exhibit 6-3	<i>Acceptable Cross Sections for Gabion Sediment Dams</i>	10

## GABION SEDIMENT DAM

### 6.1 DEFINITION

A barrier or dam composed of rock-filled wire baskets constructed across a waterway to form a silt or sediment basin.

### 6.2 SCOPE

This chapter established the minimum acceptable quality for the design and construction of gabion sediment dams located in predominantly rural or agricultural areas in West Virginia when:

1. Failure of the structure would not result in loss of life, in damages to homes, commercial or industrial buildings, main highways, or railroads, in interruption of the use or service of public utilities;
2. The contributing area does not exceed 500 acres; and
3. The vertical distance between the lowest point along the centerline of the dam and the crest of the spillway does not exceed 10 feet;
4. The vertical distance between the upstream toe of the embankment and to the crest of the emergence spillway does exceed 5 feet in height and does not have a storage volume greater than 20 acre-feet as measured at normal pool elevation. Also, does not present a hazard to coal miners as determined by the Mine Safety and Health Administration. Structures which exceed the conditions outlined in Chapter 6.2(4) shall comply with the following minimum standards:
  - a. An appropriate combination of principal and emergency spillways shall be provided to discharge safely the runoff resulting from a 100-year, 24-hour precipitation event or a large event specified by the Department of Environmental Protection Mining and Reclamation.
  - b. The embankment shall be designed and constructed with a static safety factor or at least 1.5 or higher safety factor as designated by the Department of Environmental Protection Mining and Reclamation to ensure stability.
  - c. Appropriate barriers shall be provided to control seepage along the conduits that extend through the embankment.
  - d. The criteria of the Mine Safety and Health Administration as published in 30 C.F.R. 77.216 shall be adhered to. All inspection reports and approvals shall be provided to the Director of the Department of Environmental Protection Mining and Reclamation.
5. Structures which exceed or will exceed twenty-five feet in vertical height from the natural bed of such stream or watercourse measured at the downstream toe of the barrier and which does or can impound fifteen acre-feet or more of water and/or will be six feet in vertical height from the natural bed of such stream or watercourse measured at the downstream toe of the barrier and which does or can impound fifty acre-feet or more of water.

Structures meeting these minimum requirements must be approved by the Director of the Department of Environmental Protection Mining and Reclamation in accordance with Chapter 22 Article 14 of the Code of West Virginia known as "Dam Control Act".

- Gabions can be used only where the pH of the normal stream flow, existing and expected, is to be greater than 5.0 during the life of the structure.

### 6.3 EMERGENCY SPILLWAY

An emergency spillway will be required on all gabion structures and will be designed to safely carry the expected discharge from a 25-year, 24-hour frequency storm. The crest of the spillway shall be located at the maximum elevation of the sediment pool.

All spillways shall have a rectangular cross-section as viewed along the centerline of the structure.

There shall be 1/2 foot of freeboard between the maximum design flow elevation in the spillway and the top of the dam. The expected peak rate of discharge of a storm event shall be obtained from Chapter 2, "Estimating Runoff". The spillway shall be proportioned to carry the peak discharge by the formula  $Q = CLh^{3/2}$ , where Q is the peak discharge, L is the longitudinal length of the spillway, and h is height of the spillway opening minus 0.5 feet. C is a coefficient of discharge which may be found in Exhibit 6-2.

In no case, shall the total design head on the structure exceed 13.0 feet (the sum of maximum distance from the original ground to spillway elevation plus h must be less than or equal to 13.0 feet).

The Emergency Spillway shall be located to ensure maximum travel distance between point of entry to spillway so as to prevent short circuiting to the extent possible, see Chapter 19, "Water Management Practices" for determining or altering sediment basin shape.

### 6.4 GABION CROSS-SECTION

In order to establish a uniform yet stable cross-section for this type structure, all gabion sediment dams shall have a steplike cross section with a 12-inch gabion or a 3 foot thick rock mattress covering the downstream channel and embankment. See Exhibit 6-3, for acceptable gabion sediment dam cross section of 3 feet 3 inches by 3 feet 3 inches.

The gabion or rock mattress shall extend out from the downstream toe of structure for the minimum distances shown in Exhibit 6-3. The bottom width of the mattress shall be equal to the length of the spillway and in line with it. The channel sides shall be covered by the mattress to a minimum vertical depth of 4 feet.

The upstream face of all gabion structures may be backfilled with material from the pool area. The backfill shall be on a slope of 3 horizontal to 1 vertical.

Cross-sections of additional width other than those shown and without backfill against the upstream face may be used if approved by the Director of the Department of Environmental Protection Mining and Reclamation.

### 6.5 KEY-IN OF FOUNDATION

The gabion dam shall be keyed into the abutment with the channel or valley to a minimum depth of 3 feet at any point. The bottom of the gabion may be keyed into the channel bottom. After the gabion structure is in place, the key into the abutment shall be backfilled to the embankment's original contour with compactible material. The material shall be mechanically tamped in maximum lifts of 6 inches.

## 6.6 FILLING AND BINDING GABION WIRE BASKETS

The gabion baskets shall be filled with durable limestone, river rock or sandstone of 3-7 inches in size. The stone shall be hand or machine placed in the baskets in such a manner as to prevent sagging or bulging of the basket or baskets. All edges of the baskets must be secured or bounded to the adjacent basket by lacing wire in and out of the mesh openings. The maximum distance between each coil shall not exceed 4 inches.

## 6.7 MATERIAL SPECIFICATIONS

All perimeter edges of the mesh forming each unit shall be securely selvaged with wire of not less than 0.150-inch diameter so that the joints formed by tying the selvages have at least the same strength as the body of the mesh.

Lacing wire shall be supplied in sufficient quantity for securing all edges of the gabion baskets and diaphragms and to provide for the necessary internal connection wires in each cell. The wire lacing shall meet or exceed the same specification as the wire used in the mesh.

The wire mesh shall be made of galvanized steel wire having a minimum size of U.S. Steel Wire Gauge No. 14. The tensile strength of the wire shall be in the range of 60,000 to 85,000 p.s.i. The minimum zinc coating of the wire shall be 0.80 ounces per square foot of uncoated wire surface as determined by a test or tests conducted in accordance with A.S.T.M. Designation A-90. The maximum linear dimension of the mesh opening shall not exceed 3-1/2 inches and the area of the mesh opening shall not exceed 6 square inches.

Gabions shall be fabricated in such a manner that the sides, ends, lid, and diaphragms can be assembled at the construction site into a rectangular basket of the specified sizes. Gabions shall be of single unit construction - the base, lid and sides shall be woven into a single unit and the ends shall be connected to the base section of the gabion in such a manner that strength and flexibility at the point of connection is at least equal to that of the mesh.

Where the length of the gabion exceeds 5 feet, the gabion shall be divided by diaphragms, of the same mesh and gauge as the body of the gabions, into cells of equal length and width. The gabion shall be furnished with the necessary diaphragms secured in proper position on the base in such a manner that no additional tying at this juncture will be necessary.

## 6.8 PLANS, DESIGN DATA AND SPECIFICATIONS

In addition to the "Proposed Drainage Map", there shall also be submitted the following items concerning gabion sediment dams:

1. A "Structure Proportioning Computations Sheet" to be completed for each proposed gabion sediment dam. Exhibit 6-1:
2. Construction Plans showing:
  - a. A topographic map on a 1" = 50' scale and 4-foot contour intervals showing the reservoir area, structure, two permanent reference points, showing type, elevation and azimuth or bearing between reference points, relieving stream and north arrow. Topographic map is to be made using transit-stadia survey method.
  - b. A scaled cross-section view of gabion structure at the point where the maximum depth of water will be impounded against the structure showing all pertinent dimensions and elevations.

- c. A scaled cross-section view taken along the centerline of the dam showing all pertinent dimensions and elevation.
3. A "Stage-Area-Storage Computations Sheet" and "Stage-Area Storage Curves".
4. Construction Specifications.
5. Maintenance schedule to include, but not limited to, the following: Procedures for maintenance, method of disposal of sediment and access to structure for maintenance.
6. Procedures and timetable for abandonment.

## 6.9 CONSTRUCTION SPECIFICATIONS

### 6.9.1 Site Preparation

Brush, trees and other undesirable material shall be cleared from the sediment pool and dam areas. Sod and topsoil shall be stripped from gabions foundation area.

### 6.9.2 Preparation of Foundation

Proper excavation shall be made along the foundation and sides of the gabion structure as shown on the construction plans to assure that the gabion structure will be placed on the planned line and grade.

The key into the abutments shall be excavated as shown on the construction plans. The gabion structure must be keyed into the abutment a minimum of 3 feet at any point as measured in any direction.

The fill material beneath the gabion units along the sides of the structure shall be placed in 6 inch maximum lifts and mechanically tamped.

### 6.9.3 Fill and Binding

Backfilling of the key into the abutments and against the upstream face of the gabion shall progress simultaneously with the filling and binding of the baskets. The key into the embankment shall be backfilled with compactible material to the embankment's original contour. This material shall be placed in 6 inch maximum lifts and mechanically tamped. Each gabion unit shall be bound together by a continuous piece of connecting wire stitched around the vertical edges with a coil about every 4 inches. Lacing wire shall be used to join the units together in the same manner. Empty gabion units shall be set to line and grade as shown on the plans.

A standard fence stretcher, chain fall, or steel rod may be used to stretch the wire baskets and hold alignment.

The gabions shall be filled with stone carefully placed by hand or machine to assure alignment and void bulges with a minimum of voids. After a gabion has been filled, the lid shall be bent over until it meets the sides and edges. The lid then be secured to the sides, ends and diaphragms with the lacing wire in the manner described above for assembling.

#### 6.9.4 Backfilling Upstream Face

The upstream face of the cribbing may be backfilled with material from the pool area up to the sediment pool elevation behind the spillway and up to the top of dam elevation for the remainder on a slope of 3 horizontal to 1 vertical.

Very dry or wet material shall not be used. The fill material shall be free of all sod, roots, stones over 6 inches in diameter and other objectionable material. The moisture content of the material should be such that when kneaded in the hand, it will just form a ball that will not readily separate.

The embankment shall be brought up on uniform 6-8 inch layers of approximate uniform elevation over its entire area. Each layer shall be thoroughly compacted by making at least 4 complete passes with a tamping roller or by applying compactive effort with rubber-tired equipment.

#### 6.9.5 Spillway

The spillway shall conform to the alignment and dimensions shown on the plans.

#### 6.9.6 Downstream Channel Protection

##### 6.9.6.1 Gabion Mattress

The gabion mattress or apron shall conform to the alignment and grade shown on the plans. The mattress shall be bound in the same manner prescribed for the gabion baskets. Also, the edge of the mattress against the toe of the dam shall be bound to the dam in the same manner prescribed for the gabion baskets.

##### 6.9.6.2 Rock Mattress

The channel bottom and sides downstream of the structure shall be covered to a minimum depth of 3 feet with durable rock of which fifty percent (50%) is 3 feet or larger and the remainder sized to fill the voids with a minimum size of 6 inches. The rock shall not contain more than ten percent (10%) earth, sand, or soft shale as determined by visual inspection. The rock shall extend out from the toe of the crib structure for a minimum distance of twice the height of the structure. The dumped rock shall form a trapezoidal channel with a bottom width equal or greater than the length of the spillway. The rock shall extend up the embankment sides to a minimum vertical depth of 4 feet.

#### 6.9.7 Vegetative Protection Against Erosion

All disturbed areas outside the pool area shall be seeded and mulched immediately after construction in accordance with Chapter 20 of this handbook for revegetation.

**EXHIBIT 6-1**

GABION SEDIMENT DAM  
STRUCTURE PROPORTIONING COMPUTATION SHEET

Gabion Number \_\_\_\_\_

SEDIMENT STORAGE REQUIREMENTS

Drainage Area = \_\_\_\_\_ Ac.

Area Disturbed + \_\_\_\_\_ Ac.

Sediment Volume = 0.125 Ac. Ft./Acre Times Disturbed Area Controlled by  
Gabion Number \_\_\_\_\_ = \_\_\_\_\_ Ac. Ft.

Sediment Pool Elevation \_\_\_\_\_ = Emergency Spillway Elevation

EMERGENCY SPILLWAY DESIGN

Peak Discharge (Q) (Exhibit 2-7) = \_\_\_\_\_ cfs

Spillway Breath = \_\_\_\_\_ Ft.

Spillway Height Minus 0.5 Ft.; h = ( \_\_\_\_\_ ) Spillway Breath

(-) 0.5 Ft. = \_\_\_\_\_ Ft.

Coefficient of Discharge (C) (Exhibit \_\_\_\_\_) = \_\_\_\_\_

Minimum Spillway Length [L = Q/Ch (3/2)] = \_\_\_\_\_ Ft.

\*The three-halves power of h may be obtained from Table No. 1

Planned Spillway Length \_\_\_\_\_ Ft.

Top of Gabion Elevation ( \_\_\_\_\_ ) = Emergency Spillway

Elevation ( \_\_\_\_\_ ) + Spillway Height ( \_\_\_\_\_ )

**TABLE 6-1**  
**THREE-HALVES POWERS OF NUMBERS**

No.	.00	.01	.02	.03	.04	.05	.06	.07	.08	.09
1.5	1.837	1.856	1.874	1.892	1.911	1.930	1.948	1.967	1.986	2.005
1.6	2.024	2.043	2.062	2.081	2.100	2.120	2.139	2.158	2.178	2.197
1.7	2.216	2.236	2.256	2.276	2.295	2.315	2.335	2.355	2.375	2.395
1.8	2.415	2.435	2.455	2.476	2.496	2.516	2.537	2.557	2.578	2.598
1.9	2.619	2.640	2.660	2.681	2.702	2.723	2.744	2.765	2.786	2.807
2.0	2.828	2.850	2.871	2.892	2.914	2.935	2.957	2.978	3.000	3.022
2.1	3.043	3.065	3.087	3.109	3.131	3.153	3.174	3.197	3.219	3.241
2.2	3.263	3.285	3.308	3.330	3.352	3.375	3.398	3.420	3.443	3.465
2.3	3.488	3.511	3.534	3.557	3.580	3.602	3.625	3.649	3.672	3.695
2.4	3.718	3.741	3.765	3.788	3.811	3.835	3.858	3.882	3.906	3.929
2.5	3.953	3.977	4.000	4.024	4.048	4.072	4.096	4.120	4.144	4.168
2.6	4.192	4.217	4.241	4.265	4.290	4.314	4.338	4.363	4.387	4.412
2.7	4.437	4.461	4.486	4.511	4.536	4.560	4.585	4.610	4.635	4.660
2.8	4.685	4.710	4.736	4.761	4.786	4.811	4.837	4.862	4.888	4.913
2.9	4.938	4.964	4.990	5.015	5.041	5.067	5.093	5.118	5.144	5.170
3.0	5.196	5.222	5.248	5.274	5.300	5.327	5.353	5.379	5.404	5.432
3.1	5.458	5.481	5.511	5.538	5.564	5.591	5.617	5.644	5.671	5.698
3.2	5.724	5.751	5.778	5.805	5.832	5.859	5.886	5.913	5.940	5.968
3.3	5.995	6.022	6.049	6.077	6.104	6.132	6.159	6.186	6.214	6.242
3.4	6.269	6.297	6.325	6.352	6.380	6.408	6.436	6.464	6.492	6.520
3.5	6.548	6.576	6.604	6.632	6.660	6.689	6.717	6.745	6.774	6.802
3.6	6.830	6.859	6.888	6.916	6.945	6.973	7.002	7.031	7.060	7.088
3.7	7.117	7.146	7.175	7.204	7.233	7.262	7.291	7.320	7.349	7.378
3.8	7.408	7.437	7.466	7.496	7.525	7.554	7.584	7.613	7.643	7.672
3.9	7.702	7.732	7.761	7.791	7.821	7.850	7.880	7.910	7.940	7.970

**TABLE 6-1**  
**THREE-HALVES POWERS OF NUMBERS**

No.	.00	.01	.02	.03	.04	.05	.06	.07	.08	.09
4.0	8.000	8.030	8.060	8.090	8.120	8.150	8.181	8.211	8.241	8.272
4.1	8.302	8.332	8.363	8.393	8.424	8.454	8.485	8.515	8.546	8.577
4.2	8.607	8.638	8.669	8.700	8.731	8.762	8.793	8.824	8.855	8.836
4.3	8.917	8.948	8.979	9.010	9.041	9.073	9.104	9.135	9.167	9.198
4.4	9.230	9.261	9.292	9.324	9.356	9.387	9.419	9.451	9.482	9.514
4.5	9.546	9.578	9.610	9.642	9.674	9.706	9.738	9.770	9.802	9.834
4.6	9.866	9.898	9.930	9.963	9.995	10.03	10.06	10.09	10.12	10.16
4.7	10.19	10.22	10.25	10.29	10.32	10.35	10.39	10.42	10.45	10.43
4.8	10.52	10.55	10.58	10.62	10.65	10.68	10.71	10.75	10.78	10.81
4.9	10.85	10.88	10.91	10.95	10.98	11.01	11.05	11.08	11.11	11.15
5.0	11.18	11.21	11.25	11.28	11.31	11.35	11.38	11.42	11.45	11.48
5.1	11.52	11.55	11.59	11.62	11.65	11.69	11.72	11.76	11.79	11.82
5.2	11.86	11.89	11.93	11.96	11.99	12.03	12.06	12.10	12.13	12.17
5.3	12.20	12.24	12.27	12.31	12.34	12.37	12.41	12.44	12.48	12.51
5.4	12.55	12.58	12.62	12.65	12.69	12.72	12.76	12.79	12.83	12.86
5.5	12.90	12.93	12.97	13.00	13.04	13.07	13.11	13.15	13.18	13.22
5.6	13.25	13.29	13.32	13.36	13.39	13.43	13.47	13.50	13.54	13.57
5.7	13.61	13.64	13.68	13.72	13.75	13.79	13.82	13.86	13.90	13.93
5.8	13.97	14.00	14.01	14.08	14.11	14.15	14.19	14.22	14.26	14.29
5.9	14.33	14.37	14.40	14.44	14.48	14.51	14.55	14.59	14.62	14.66
6.0	14.70	14.73	14.77	14.81	14.84	14.88	14.92	14.95	14.99	15.03
6.1	15.07	15.10	15.14	15.18	15.21	15.25	15.29	15.33	15.36	15.40
6.2	15.44	15.48	15.51	15.55	15.59	15.62	15.66	15.70	15.74	15.78
6.3	15.81	15.85	15.89	15.93	15.96	16.00	16.04	16.08	16.12	16.15
6.4	16.19	16.23	16.27	16.30	16.34	16.38	16.42	16.46	16.50	16.53

**TABLE 6-1**  
**VALUES OF C IN THE FORMULA  $Q = CLh^{3/2}$**

*Height of Weir h	Breadth of weir in feet					
	3.25	4.00	5.00	6.00	10.00	15.00
1.0	2.65	2.67	2.68	2.68	2.68	2.63
1.2	2.65	2.67	2.66	2.67	2.69	2.64
1.4	2.64	2.65	2.65	2.65	2.67	2.64
1.6	2.66	2.66	2.65	2.65	2.64	2.63
1.8	2.66	2.66	2.65	2.65	2.64	2.63
2.0	2.71	2.68	2.65	2.65	2.64	2.63
2.5	2.79	2.72	2.67	2.66	2.64	2.63
3.0	2.77	2.73	2.66	2.66	2.64	2.63
3.5	2.92	2.76	2.68	2.67	2.64	2.63
4.0	3.00	2.79	2.70	2.69	2.64	2.63
4.5	3.21	2.88	2.74	2.72	2.64	2.63
5.0	3.26	3.07	2.79	2.76	2.64	2.63
5.5	3.32	3.32	2.88	2.85	2.64	2.63

\*h = Planned height of spillway minus 0.5 feet.

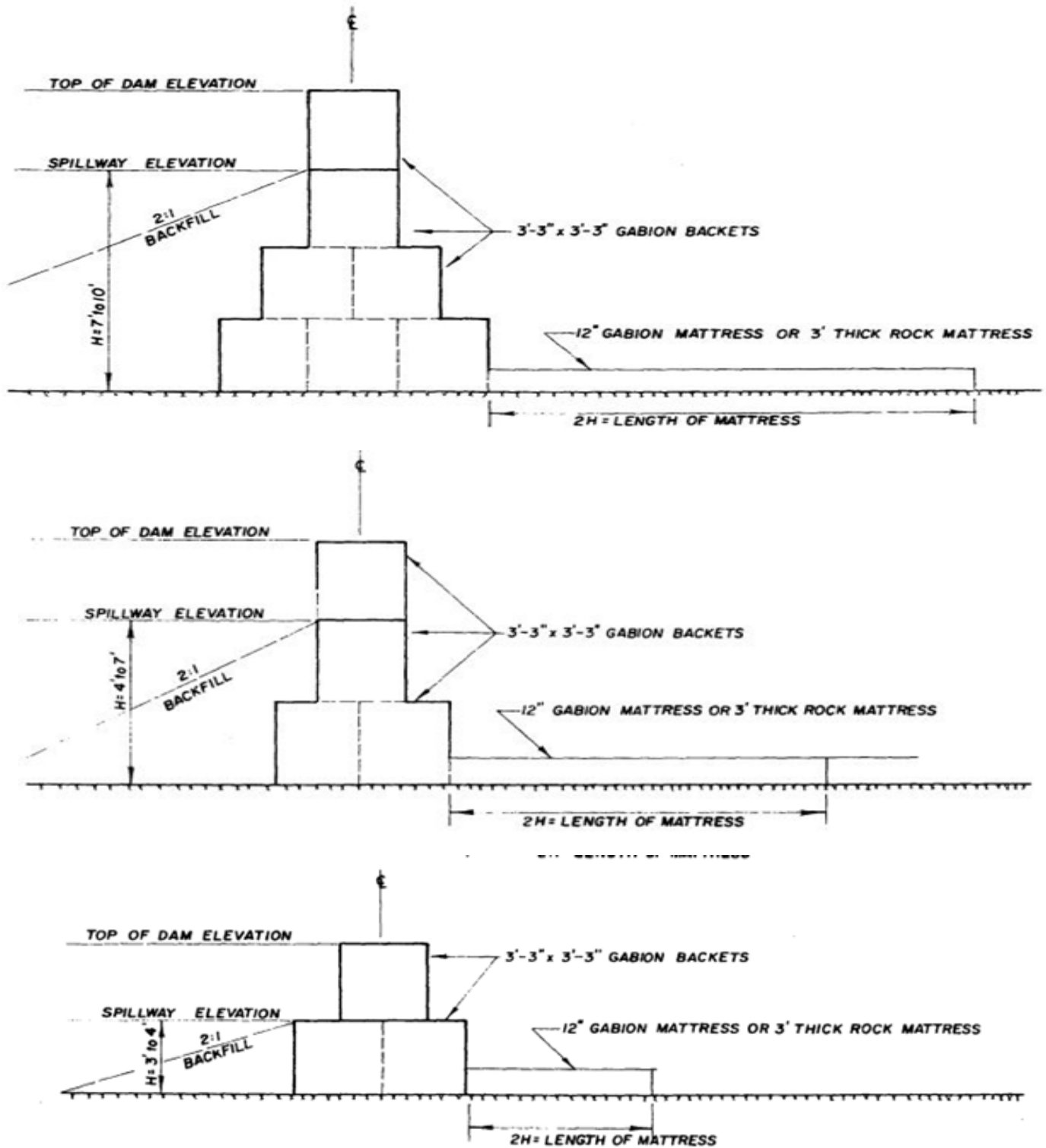

**ACCEPTABLE CROSS SECTIONS FOR  
GABION SEDIMENT DAMS**

EXHIBIT 6-3

# 7

# *Crib Sediment Dam*

## **C O N T E N T S**

Definitions	1
Scope	1
Emergency Spillway	2
Crib Dam Cross-Section	2
Key-In Abutments	2
Filling of Crib Unit	2
Material Specifications	3
	<i>Crib Fabrication</i> 3
	<i>Crib Interlocking</i> 3
	<i>Gross Volume of Crib Unit</i> 3
Plans, Design Data and Specifications	3
Construction Specifications	4
	<i>Site Preparation</i> 4
	<i>Preparation of Foundation</i> 4
	<i>Placing Crib Members</i> 4
	<i>Filling Crib</i> 4
	<i>Backfilling Upstream Face</i> 4
	<i>Backfilling Key into Abutments</i> 5
Downstream Channel Protection	5
Vegetative Protection Against Erosion	5
Exhibit 7-1	6
Exhibit 7-2	7

## CRIB SEDIMENT DAM

### 7.1 DEFINITION

A barrier or dam composed of rockfilled concrete cribbing constructed across a waterway to form a silt or sediment basin.

### 7.2 SCOPE

This chapter establishes the minimum acceptable quality for the design and construction of crib sediment dams located in predominantly rural or agricultural areas in West Virginia when:

1. Failure of the structure would not result in loss of life; in damages to homes, commercial or industrial buildings; main highways, or railroads; in interruption of the use of service or public utilities; and
2. The contributing area does not exceed 500 acres; and
3. The vertical distance between the lowest point along the centerline of the dam and the crest of the spillway does not exceed 10 feet.
4. The vertical distance between the upstream toe of the embankment and to the crest of the emergency spillway does exceed 5 feet in height and does not have a storage volume greater than 20-acre feet as measured at normal pool elevation. Also, does not present a hazard to coal miners as determined by the Mine Safety and Health Administration. Structures which exceed the conditions outlined in Chapter 7.2(3) shall comply with the following minimum standards:
  - a. An appropriate combination of principal and emergency spillways shall be provided to discharge safely the runoff resulting from a 100-year, 24-hour precipitation event or a large event specified by the Department of Environmental Protection Mining and Reclamation.
  - b. The embankment shall be designed and constructed with static safety factor or at least 1.5 or a higher safety factor as designated by the Department of Environmental Protection Mining and Reclamation to ensure stability.
  - c. Appropriate barriers shall be provided to control seepage along the conduits that extend through the embankment.
  - d. The criteria of the Mine Safety and Health Administration as published in 30 C.F.R. 77.216 shall be adhered to. All inspection reports and approvals shall be provided to the Director of the Department of Environmental Protection Mining and Reclamation.
5. Structures which is or will exceed twenty-five feet in vertical height from the natural bed of such stream or watercourse measured at the downstream toe of the barrier and which does or can impound fifteen acre-feet or more of water and/or will be six feet in vertical height or more in height from the natural bed of such stream or watercourse measured at the downstream toe of the barrier and which does or can impound fifty acre-feet or more of water.

Structures meeting these minimum requirements must be approved by the Director of the Department of Environmental Protection Mining and Reclamation in accordance with Chapter 22 Article 14 of the Code of West Virginia known as "Dam Control Act".

### 7.3 EMERGENCY SPILLWAY

An emergency spillway will be required on all crib structures and will be designed to safely carry the expected peak discharge from a 25-year, 24-hour frequency storm. The crest of the spillway shall be located at the maximum elevation of the sediment pool.

All spillways shall have a rectangular cross-section as viewed along the centerline of the structure. There shall be 1/2 foot of freeboard between the maximum design flow elevation in the spillway and the top of the dam. The expected peak rate of discharge of a storm event shall be obtained from Chapter 2, "Estimating Runoff". The spillway shall be proportioned to carry the peak discharge by the formula,  $Q = CLh^{3/2}$ , where Q is the peak discharge, L is the longitudinal length of the spillway, and h is height of the spillway opening minus 0.5 feet. C is a coefficient of discharge which may be found in Exhibit 6.2.

In no case, shall the total design head on the structure exceed 13.0 feet (the sum of the maximum distance from original ground to the spillway elevation plus h must be less than or equal to 13.0 feet).

The emergence spillway shall be located to ensure maximum travel distance between point of entry to spillway so as to prevent short circuiting to the extent possible, see Chapter 19, "Water Management Practices", for procedures for determining or altering sediment basin shape.

### 7.4 CRIB DAM CROSS-SECTION

In order to establish a uniform, yet stable cross-section, See Exhibit 7-2 for this type structure; All crib sediment dams shall:

1. Be a minimum of 6 feet in width; that is, the distance from inside to inside of headers must be 6 feet or more.
2. May be backfilled with material from the pool area on the upstream face. The slope of the backfill shall be a minimum of 3 horizontal to 1 vertical.
3. Have the channel bottom and sides downstream of the structure covered to a minimum depth of 3 feet with durable rock mattress of which fifty percent (50%) is 3 feet or larger and the remainder sized to fill the voids with a minimum size of 6 inches; or have the channel bottom and sides downstream of the structure cover a 12-inch gabion mattress. The rock or gabion mattress extend out from the toe of the structure for a minimum distance of twice the height of the structure.

### 7.5 KEY-IN ABUTMENTS

The crib dam shall be keyed into the abutments with the channel or valley to a minimum depth of 3 feet at any point. The foundation of the crib dam shall be keyed into the channel bottom to a minimum depth of 1 foot. After the crib structure is in place, the key into the abutments shall be backfilled to the embankment's original contour with compactible material. The material shall be mechanically tamped in maximum lifts to 6 inches.

### 7.6 FILLING OF CRIB UNIT

Crib fill material shall consist of durable limestone, sandstone or rock. The stone shall be hand or machine placed inside the cribbing in such a manner as to minimize the void space. If open-faced cribbing is used,

the stone fill shall have a minimum size of 1 inch greater than that of the crib's vertical opening. If closed-faced cribbing is used, the stone fill shall be 3-7 inches in size.

## 7.7 MATERIAL SPECIFICATION

### 7.7.1 CRIB FABRICATION

Reinforced concrete cribbing shall be manufactured of dense, impermeable concrete, developing a compressive strength of not less than 4000 pounds per square inch in 28 days. Crib units shall be made in rigid steel forms and compacted by vibration. The surfaces of all members shall contain no recesses or depressions. Mesh or bar reinforcing shall be used with the steel placed such as to act integrally with the concrete in resisting design stresses.

### 7.7.2 CRIB INTERLOCKING

Headers shall be made with reinforced projecting lugs to serve as the locking device. If other types of locking devices are employed, the manufacturer shall furnish proof of strength of such device based on test results from a qualified laboratory.

Concrete crib cams covered by these specifications shall be of the true crib type having stretchers running longitudinally with the wall at both the front and rear, and headers lying transversely to support the ends of the stretchers and tie the structure together.

### 7.7.3 GROSS VOLUME OF CRIB UNIT

The total volume of concrete contained in all crib units shall represent at least sixteen percent (16%) of the gross volume of the crib wall with the filling in place.

## 7.8 PLANS, DESIGN DATA AND SPECIFICATIONS

In addition to the "Proposed Drainage Map", there shall also be submitted the following items concerning crib sediment dams:

1. A "Structure Proportioning Computations Sheet" to be completed for each proposed crib sediment dam. Exhibit 7-1
2. Construction Plans showing:
  - a. A topographic map on a 1" - 50' scale and 4-foot contour intervals showing the reservoir area, structure, two permanent reference points showing the reservoir area, structure, two permanent reference points showing type, elevation and azimuth or bearing between reference points, relieving stream, and north arrow. Topographic map is to be made using transit-stadia survey method.
  - b. A scaled cross-section view of gabion structure at the point where the material depth of water will be impounded against the structure showing all pertinent dimensions and elevations.
  - c. A scaled cross-section view taken along the centerline of the dam showing all pertinent dimensions and elevations.
3. A "Stage-Area-Storage Computations Sheet" and "Stage-Area-Storage Curves".

4. Construction Specifications.
5. Maintenance schedule to include, but not limited to, the following: Procedures for maintenance, method of disposal of sediment and access to structure for maintenance.
6. Procedures and timetable for abandonment.

## 7.9 CONSTRUCTION SPECIFICATIONS

### 7.9.1 SITE PREPARATION

Brush, trees and other undesirable material shall be cleared from the sediment pool and dam areas. Sod and topsoil shall be stripped from crib's foundation area.

### 7.9.2 PREPARATION OF FOUNDATION

Proper excavation shall be made along the foundation and sides of the crib structure as shown on the construction plans to assure that the crib will be placed on the planned line and grade.

The key into the abutments shall be excavated as shown on the construction plans. The crib structure must be keyed into the abutments to a minimum of 3 feet at any point. The crib structure will be keyed into the channel bottom to a minimum depth of 1 foot.

When the cribbing is on the fill materials, the fill material beneath the cribbing shall be placed in 6 inch maximum lifts and mechanically tamped.

### 7.9.3 PLACING CRIB MEMBERS

The prepared foundation bed for the cribbing shall be firm and normal to the face of the cribbing. The crib members shall be taken to insure the correct alignment.

The crib members shall be handled carefully and, members that become cracked or otherwise damaged shall be removed and new members substituted.

### 7.9.4 FILLING CRIB

The filling of the interior, backfilling against the upstream face, backfilling key into embankment, and dumped rock against downstream face shall progress simultaneously with the erection of the cribbing. The interior of the cribbing shall be filled with durable limestone, sandstone, or river bedrock which shall be hand or machine placed inside the cribbing in such a manner as to minimize the void space. If open faced cribbing is used, the stone fill shall have a minimum size of 1 inch greater than that of the crib's vertical opening. If closed cribbing is used, the stone fill shall be 3-7 inches in size.

### 7.9.5 BACKFILLING UPSTREAM FACE

The upstream face of the cribbing may be backfilled with material from the pool area up to the sediment pool elevation behind the spillway and up to the top of the dam elevation for the remainder on a maximum slope of 3 horizontal to 1 vertical.

Very dry or wet material shall not be used. The fill material shall be free of sod, roots, stones over 6 inches in diameter and other objectionable material. The moisture content of the material should be such that when kneaded in the hand, it will just form a ball that will not readily separate.

The embankment shall be brought up on uniform 6-8 inch layers of approximate uniform elevation over its entire area. Each layer shall be thoroughly compacted by making at least 4 complete passes with a tamping roller or by applying equal compactive effort with rubber-tired equipment.

#### 7.9.6 BACKFILLING KEY INTO ABUTMENTS

The key into the abutments shall be backfilled to the embankment's original contour with compactible material. This material shall be placed in 6-inch maximum lifts and mechanically tamped.

#### 7.9.7 DOWNSTREAM CHANNEL PROTECTION

##### 7.8.7.1 ROCK MATTRESS

The channel bottom and sides downstream of the structure shall be covered to a minimum depth of 3 feet with durable rock of which fifty percent (50%) is 3 feet or larger and the remainder sized to fill the voids with minimum size of 6 inches. The rock shall not contain more than ten percent (10%) earth, sand or soft shale as determined by visual inspection. The rock shall extend out from the toe of the crib structure. The duped rock shall form a trapezoidal channel with a bottom width equal or greater than the length of the spillway. The rock shall extend up the embankment sides for a minimum vertical depth of 4 feet.

##### 7.9.7.2 GABION MATTRESS

The channel bottom and sides downstream of the structure shall be covered with a 12-inch gabion mattress. The mattress shall form a trapezoidal channel with a bottom length equal to or greater than the length of the spillway. The mattress shall extend up the embankment to a minimum distance of twice the height of the structure.

Material specifications, binding and filling of gabion mattress baskets shall be as outlined under GABION SEDIMENT DAMS.

#### 7.9.8 VEGETATIVE PROTECTION AGAINST EROSION

All disturbed areas outside the pool area shall be mulched and vegetated in accordance with Chapter 20 of this handbook on revegetation.

**EXHIBIT 7-1**

CRIB SEDIMENT DAM  
Structure Proportioning Computation Sheet

Crib Number \_\_\_\_\_

SEDIMENT STORAGE REQUIREMENTS

Drainage Area = \_\_\_\_\_ Ac.

Area Disturbed = \_\_\_\_\_ Ac.

Sediment Volume = 0.125 Ac. Ft./Acre Times Disturbed Area Controlled

By Crib Number \_\_\_\_\_ = \_\_\_\_\_ Ac. Ft.

Sediment Pool Elevation \_\_\_\_\_ = Emergency Spillway Elevation

EMERGENCY SPILLWAY DESIGN

Peak Discharge (Q) (Exhibit 2-7) = \_\_\_\_\_ cfs

Spillway Breath = \_\_\_\_\_ Ft.

Spillway Height Minus 0.5 Ft.; h = ( \_\_\_\_\_ ) Spillway

Breath (-) 0.5 Ft. = \_\_\_\_\_ Ft.

Coefficient of Discharge (C) (Exhibit \_\_\_\_\_) = \_\_\_\_\_

Minimum Spillway Length [L = Q/Ch (3/2\*)] = \_\_\_\_\_ Ft.

\*The three-halves power of h may be obtained from Table No. 1

Planned Spillway Length \_\_\_\_\_ Ft.

Top of Crib Elevation ( \_\_\_\_\_ ) = Emergency Spillway

Elevation ( \_\_\_\_\_ ) + Spillway Height ( \_\_\_\_\_ )

EXHIBIT 7-2

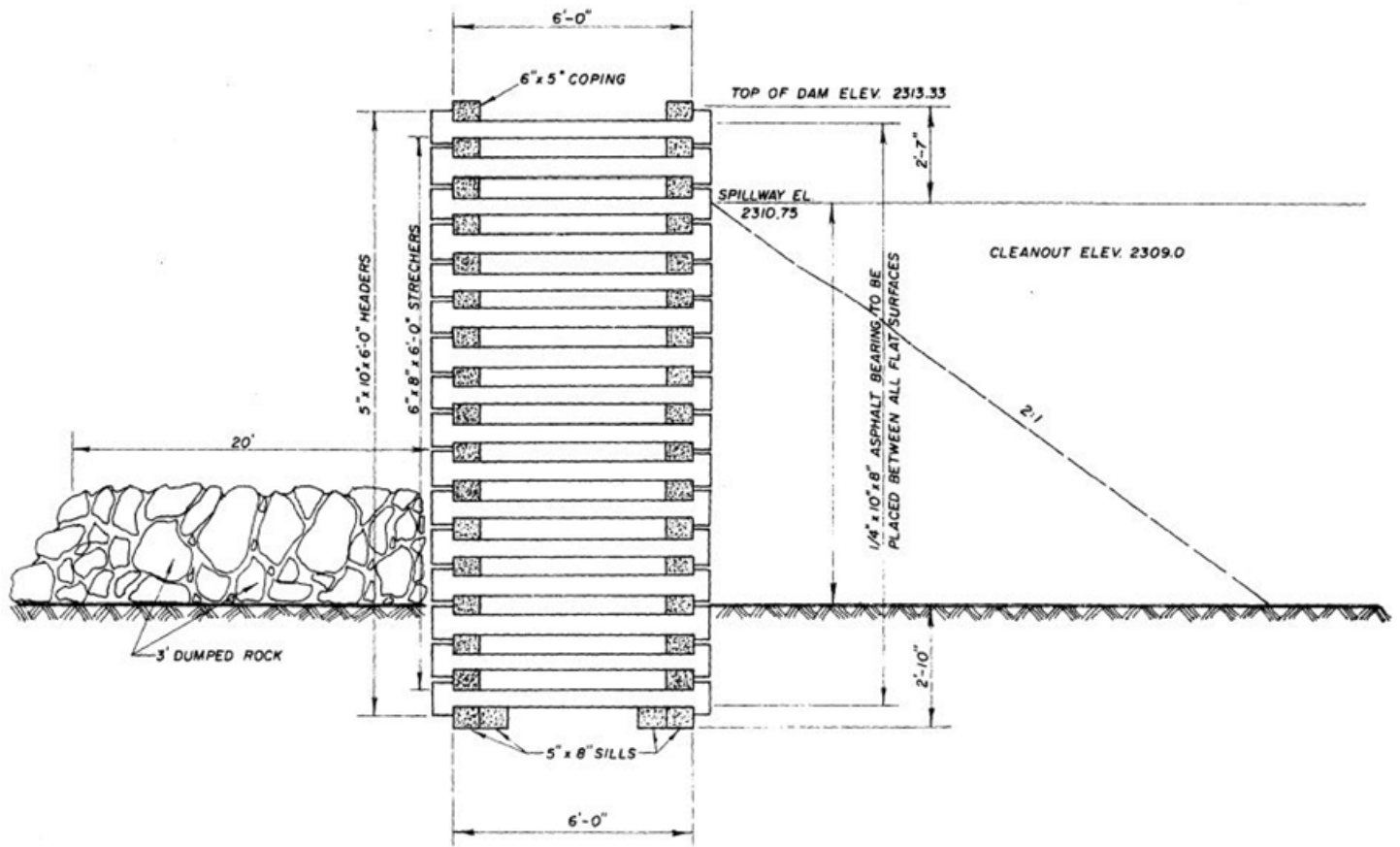

CROSS SECTION VIEW OF CRIB DAM NO.2

# 8 *Valley or Head- of-Hollow fills*

## **C O N T E N T S**

Definition	1
Purpose	1
Location	1
Stabilization	1
Drainage	1
Geotechnical Investigation	2
Minimum Design Requirements	2
Plans, Design Data and Construction Specifications	3
Construction Specifications	3
Certification	4
Sediment Control Requirement	4
	<i>Disturbance Within Fill Site</i> 4
	<i>Location of Sediment Structures</i> 4
Temporary Storage of Overburden to be Used for Backfilling & Regrading	5

## VALLEY OR HEAD-OF-HOLLOW FILLS

### 8.1 DEFINITION

A fill structure consisting of any material, other than coal processing waste and organic material, placed across or through the head of a valley or hollow where side slopes of the existing hollow measured at the steepest point are greater than 20 degrees or the average slope of the profile of the hollow from the toe of the fill to the top of the fill is greater than 10 degrees, known as "Valley Fill".

### 8.2 PURPOSE

The valley or head-of-hollow fill method was developed to improve aesthetics, reduce landslides, allow for full recovery of one or more coal seams, and produce rolling land that is suitable for the post-mining land use.

This method provides permanent storage space for excess spoil, which is not required to achieve the approximate original contour, to be transported to and placed in a controlled manner.

This method provides temporary space for excess spoil or overburden, which shall be used for backfilling and regrading, to be transported to and placed in a controlled manner.

Areas which are free of underground mine openings or wet weather springs should be selected for valley or head-of-hollow fills. The size of the selected hollow must be such that the excess overburden generated by the mining operation will be utilized in the fill.

Instead of unstable out-slope with its potential for slides and erosion, or islands of isolated land with no access, a large, stable, fairly level area can be constructed with this method.

### 8.3 LOCATION

The valley fill area shall be located on the most moderate slopes and naturally stable areas available. Where possible, fill materials suitable for disposal shall be placed upon or above a natural terrace, bench, or berm, if such placement provides additional stability and prevents mass movement.

### 8.4 STABILIZATION

All organic material shall be removed from the disposal area, and the topsoil must be removed and segregated before the material is placed in the area. Suitable organic material may be used as mulch or may be included in the topsoil. The spoil shall be transported and placed in a controlled manner, concurrently compacted as necessary to insure long-term mass stability and prevent mass movement. In all cases, rock toe buttress of sufficient size to prevent mass movement shall be designed and constructed. The fill shall be drained and graded to allow surface and subsurface drainage to be compatible with the natural surroundings.

### 8.5 DRAINAGE

Drainage for valley fills shall consist of a rock drain constructed through the fill from the original valley floor up to the finished ground line to provide a permanent means of conveying surface runoff past the fill area. The rock core shall be progressively brought up with the remainder of the fill. The rock shall

consist of non-degradable, non-acid or toxic forming rock such as natural sand and gravel, sandstone, limestone or other durable rock that will not slake in water and will be free of coal, clay or shale. During and after construction, the top of the fill shall be graded to drain back to the head of the fill and to the rock core. Maximum slope of the top of the fill shall be three percent (3%). At no time during and after construction shall runoff from the top of the fill be discharged over the face of the fill.

A drainage pocket shall be maintained at the head of the fill during and after construction to intercept surface runoff and discharge the runoff through or over the rock core. In no case, shall this pocket or sump have a potential for impounding more than 10,000 cubic feet of water.

The top of the rock drain shall form a trapezoidal channel for possible flows over the core instead of through it in the event the pores of the core become blocked by debris or sediment. The minimum base width of the channel shall be 8 feet and the minimum depth of the channel shall be 2 feet.

The valley fill area should not contain springs, natural water courses or wet weather seeps unless lateral drains are constructed from the wet areas to the rock core in such a manner that infiltration of the water into the fill will be prevented. If springs, natural water courses or wet weather seeps are encountered, a system of under drains shall be constructed from each spring or seepage area as lateral drains to the rock core. If no filter is designed for the underdrain or rock core sufficient capacity shall be provided to allow for partial plugging of the drain and/or rock core. Rock used in the underdrain shall consist of non-degradable, non-acid or toxic forming rock such as a natural sand and gravel, sandstone, limestone or other durable rock that will not slake in water and will be of coal, clay or shale. No single rock utilized in the underdrain and/or rock core may occupy more than 25 percent of the width of the drain and/or core.

## 8.6 GEOTECHNICAL INVESTIGATION

Each application shall contain the results of a geotechnical investigation of the proposed disposal site. The investigation shall include such factors as adverse geologic conditions, soil characteristics and depth in foundation zones, bedrock, springs, seeps and groundwater flow, potential effects of subsidence and a description of the materials to be placed in rock cores and drains. The level of such geotechnical investigation shall be determined by a Registered Professional Engineer based upon specific site conditions, available site information, additional engineering data required for design and the history of similar facilities in nearby areas.

## 8.7 MINIMUM DESIGN REQUIREMENTS

All valley fills shall be designed by a Registered Professional Engineer. The following minimum design requirements must be met:

1. The foundation of the fill shall be designed to assure that the valley fill will have a long-term static factor of safety of 1.5.
2. The outer slope of the fill shall be no steeper than 2 horizontal to 1 vertical. A minimum 20-foot wide bench, or greater as approved by the Director of the Department of Environmental Protection Mining and Reclamation, shall be installed at a maximum of every 50 feet in vertical height of the fill with a 3 percent to 5 percent slope towards the fill, normal to such, and 1 percent towards the rock core.
3. A rock core shall be designed with a minimum width of 16 feet and composed of durable rock with a minimum dimension of 12 inches. The rock core shall consist of no more than 10 percent fines (fines being a dimension less than 12 inches.)

4. All drainage structure and appurtenance to be designed to handle safely pass a 100-year, 24-hour perception event.

## 8.8 PLANS, DESIGN DATA AND CONSTRUCTION SPECIFICATIONS

1. A profile view of the valley fill showing the original ground line as surveyed with 100 foot stations and proposed constructed limits.
2. A cross-section located through the midpoint of the bench shoeing the original ground line as surveyed and proposed constructed limits.
3. A cross-section located through the intersection of the top and the face of the proposed valley fill showing the original ground line as surveyed and proposed constructed limits.
4. A cross-section of the rock core.
5. A plan-view and cross-section of designed rock toe buttress.
6. Design of foundation to insure a long term static safety factor of 1.5.
7. Details of foundation preparations; keyways, etc.
8. Construction Specifications.

## 8.9 CONSTRUCTION SPECIFICATIONS

Construction of the fill shall be as follows:

1. All areas upon which a valley fill is to be placed shall first be cleared progressively of all trees, brush, shrubs, and other organic material. This material shall be removed from the fill area. No more than 3.0 acres, excluding roadway for construction of fill, shall be cleared in the valley fill site until the first lift is completed;
2. A rock core shall be progressively constructed as the layers are brought up through the valley fill.
3. Depositing and compacting valley fill in layers shall begin at the toe of the fill. The layers shall be constructed approximately parallel with proposed finish grade. All material shall be deposited in uniform horizontal layers and compacted with haulage equipment;
4. The thickness of the layers shall not exceed 4 feet;
5. During and after construction, the top of the fill shall be graded to drain back to the head of the fill on a slope no greater than three percent (3%). A drainage pocket shall be maintained at the head of the fill at all times to intercept surface runoff. Maximum size of the drainage pocket shall be 10,000 cubic feet;
6. When construction of each lift (maximum of every 50 feet in vertical height) of the valley fill is completed, topsoil or other suitable material which will support vegetation shall be spread over the

completed slope and bench excluding the rock core. The completed slope and bench shall then be seeded and mulched immediately in accordance with the approved revegetation plan; and

7. Specifications of proposed rock toe buttress.

## 8.10 CERTIFICATION

Certification of the fill shall be as follows:

1. The fill shall be designed using recognized professional standards and certified by an approved Register Professional Engineer.
2. The fill shall be inspected for stability by an approved Registered Professional Engineer experienced in the construction of earth and rock fill embankments approved by the Director of the Department of Environmental Protection Mining and Reclamation; quarterly throughout construction and during the critical construction periods such as removal of all organic material; topsoil; placement of underdrain system; installation of surface drainage systems; and revegetation in accordance with the approved Plans, Design Data and Specifications. After completion of the inspection by the approved Registered Professional Engineer, a certified report shall be submitted to the Department of Environmental Protection Mining and Reclamation within 2 weeks after conducting inspection. A copy of the certified report shall be maintained at the mine site.
3. After total completion of the valley fill, a DR-13 (Certification Form) shall be completed in accordance with Chapter 16 of the Handbook and submitted to the Department of Environmental Protection Mining and Reclamation.

## 8.11 SEDIMENT CONTROL REQUIREMENT

A sediment control structure(s) will be required to have a storage volume of 0.125 acre-foot per acre of the proposed disturbance of the valley or head-of-hollow fill area and proposed mining operation above fill. A variance may be granted to the required storage volume of the valley or head-of hollow only if a Registered Professional Engineer can insure that all applicable water quality standards and effluent limitations can be met. Then the sediment control structure(s) will have a storage volume of 0.125 acre-foot per acre of disturbance of the minimum face area.

### 8.11.1 DISTURBANCE WITHIN FILL SITE

At no time shall the disturbance in the valley fill area be greater than the sediment storage requirement provided by the sediment structure until two or more lifts of the fill have been installed.

### 8.11.2 LOCATION OF SEDIMENT STRUCTURES

All sediment control structures for fill areas shall be contiguous with the fill area but not in such proximity so as to affect mass stability.

## **8.12 TEMPORARY STORAGE OF OVERBURDEN TO BE USED FOR BACKFILLING & REGRADING**

1. All material to be used in final regrading must be placed within the permit area as specified in the approved preplan in a manner which will ensure mass stabilization and adhered to all applicable rules and regulations governing excess spoil disposal.
2. All sections of this chapter in the Technical Handbook shall be adhered to.

# 9

# *Side Hill Fills*

## **C O N T E N T S**

Definition	1
Purpose	1
Location	1
Stabilization	1
Drainage	1
Geotechnical Investigation	2
Minimum Design Requirements	2
Plans, Design Data and Construction Specifications	2
Construction	3
Certification	3
Sediment Control Requirements	4
	<i>Location of Sediment Control Structures</i>
Temporary Storage of Overburden to be Used in Backfilling and Regrading	4

## SIDE HILL FILLS

### 9.1 DEFINITION

A controlled earth and rock fill other than a valley of head-of-hollow fill to form a stable, permanent storage space for excess surface mining overburden, known as "Side Hill Fill."

### 9.2 PURPOSE

The side hill fill method was developed to improve aesthetics, reduce landslides, allow for full recovery of one or more coal seams, produce rolling land that is suitable for the post-mining land use.

This method provides permanent storage space for excess spoil, which is not required to achieve the approximate original contour, to be transported to and placed in a controlled manner.

This method provides temporary storage space for excess spoil or overburden, which shall be used for backfilling and regrading, to be transported to and placed in a controlled manner.

Instead of unstable out-slopes with its potential for slides and erosion or islands of isolated land with no access, a large, stable, fairly level area can be constructed with this method.

### 9.3 LOCATION

The side hill fill shall be located on the most moderate slopes and naturally stable areas available. Where possible, fill materials suitable for disposal shall be placed upon or above a natural terrace, bench, or berm, if such placement provides additional stability and prevents mass movement. The proposed fill area ground slopes will exceed twenty percent (20%) or a lesser amount determined by the Department of Environmental Protection Mining and Reclamation.

### 9.4 STABILIZATION

All organic material shall be removed from the disposal area and the topsoil must be removed and segregated before the overburden is placed in the disposal area.

Suitable organic material may be used as mulch or may be included in the topsoil. The spoil shall be transported and placed in a controlled manner, concurrently compacted as necessary to ensure long-term mass stability and prevent mass movement. In all cases, rock toe buttress of sufficient size to prevent mass movement shall be designed and constructed. The fill shall be drained and graded to allow surface and subsurface drainage to be compatible with the natural surroundings.

### 9.5 DRAINAGE

The disposal area side hill fill should not contain springs, natural water courses or wet weather seeps unless lateral drains are constructed from the wet areas (and disposed) in such a manner that infiltration of the water into the fill shall be prevented. The drains shall be designed and constructed of coarse rock. If no filter is designed for the underdrain, sufficient capacity shall be provided to allow for partial plugging of the drain. Rock used in the underdrain shall consist of non-degradable, non-acid or toxic forming rock such as natural sand and gravel, sandstone, limestone or other durable rock that will not slake in water and

will be free of coal, clay or shale. No single rock utilized in the underdrain may occupy more than 25 percent of the width of the drain.

Surface water runoff from and around the side hill fill surface shall be diverted away from the fill and into stabilized channels designed to pass safely the runoff from a 100-year, 24-hour precipitation event. See Chapter 11, "Diversion" unless other acceptable method(s) is approved by the Division of Mining and Reclamation.

## 9.6 GEOTECHNICAL INVESTIGATION

Each application shall contain the results of a geotechnical investigation of the proposed disposal area. The investigation shall include such factors as adverse geologic conditions, soil characteristics and depth, bedrock, springs, seeps and groundwater flow, potential effects of subsidence, and a description of materials to be placed in the fill and drains. The level of such geotechnical investigation shall be determined by a Registered Professional Engineer based upon specific site conditions, available site information, the history of similar fills in nearby areas and additional engineering data required for design.

## 9.7 MINIMUM DESIGN REQUIREMENTS

All side hill fills shall be designed by a Registered Professional Engineer. The following minimum design requirements must be met:

1. The foundation of the fill shall be designed to assure that the valley fill will have a long-term static factor of safety of 1.5.
2. The outer slope of the fill shall be no steeper than 2 horizontal to 1 vertical. A minimum 20-foot-wide bench, or greater as approved by the Director of the Department of Environmental Protection Mining and Reclamation, shall be installed at a maximum of every 50 feet in vertical height of the fill with a 3 percent to 5 percent slope towards the fill, normal to such, and 1 percent towards a stabilized channel capable of safely passing a 100-year, 24-hour precipitation event.
3. A subsurface drainage system shall be provided to safely collect and transport water from springs and seeps to the surface where it cannot affect the stability of the fill. Underdrains shall be constructed of durable rock and shall be provided with a filter unless the drain is designed of a sufficient capacity to allow for partial plugging.

## 9.8 PLANS, DESIGN DATA AND CONSTRUCTION SPECIFICATIONS

1. A cross-section of the side hill fill showing the original ground line and proposed finished grade at 200 foot stations.
2. Submit plans, design data and construction specifications for diversion in accordance to Chapter 11, "Diversion".
3. A planview and cross section of designed rock toe buttress.
4. Design of foundation to ensure a long-term static safety factor of 1.5, if applicable.
5. Details of foundation preparation; keyways, etc.
6. Construction specifications.

## 9.9 CONSTRUCTION

Construction of the fill shall be as follows:

1. All areas upon which the fill is to be placed shall first be progressively cleared of all trees, brush, shrubs and other organic material. This material shall be removed from the fill area;
2. Depositing and compacting of the fill-in layers shall begin at the toe of the fill. The layers shall be constructed approximately parallel with proposed finish grade. All material shall be deposited in uniform horizontal layers and compacted with haulage equipment;
3. The thickness of the layers shall not exceed 4 feet;
4. When construction of each lift (maximum of every 50 feet in vertical height) of the fill is completed, topsoil or other suitable material which will support vegetation shall be spread over the completed slope and bench. The slopes and benches shall then be seeded and mulched immediately in accordance with the approved revegetation plans.
5. Specifications of proposed rock toe buttress.

## 9.10 CERTIFICATION

Certification of the fill shall be as follows:

1. The fill shall be designed using recognized professional standards and certified by an approved Registered Professional Engineer.
2. The fill shall be inspected for stability by an approved Registered Professional Engineer experienced in the construction of earth and rock fill embankments approved by the Director of the Department of Environmental Protection Mining and Reclamation, quarterly throughout construction and during the critical construction periods such as removal of all organic material; topsoil; placement of underdrain system; installation of surface drainage systems; and revegetation in accordance with the approved Plans, Design Data and Specifications.

After completion of the inspection by the approved Registered Professional Engineer, a certified report shall be submitted to the Division of Mining and Reclamation within 2 weeks after conducting inspection. A copy of the certified report shall be maintained at the mine site.

3. After total completion of the valley fill, a MR13 (Certification Form) shall be completed in accordance with Chapter 16 of the Technical Handbook and submitted to the Division of Mining and Reclamation.
4. Where fills are placed on slopes greater than twenty percent (20%), a certification shall be required.

## **9.11 SEDIMENT CONTROL REQUIREMENTS**

A sediment control structure(s) will be required to have a storage volume of 0.125 acre-foot per acre of the proposed disturbance of the side hill fill area and proposed mining operation above fill.

### **9.11.1 LOCATION OF SEDIMENT CONTROL STRUCTURES**

All sediment control structures for fill areas shall be contiguous with the fill area but not in such proximity so as to affect mass stability.

## **9.12 TEMPORARY STORAGE OF OVERBURDEN TO BE USED IN BACKFILLING AND REGRADING**

1. All material to be used in final regrading must be placed within the permit area as specified in the approved pre-plan in a manner which will ensure mass stabilization and adhere to all applicable rules and regulations governing excess spoil disposal.
2. All sections of this chapter in the Technical Handbook shall be adhered to.

# *10 Durable Rock Fills*

## *C O N T E N T S*

Definition	1
Purpose	1
Location	1
General Requirements	1
Stability	1
	<i>Surface Evaluation</i> 1
	<i>Subsurface Investigation</i> 1
	<i>Laboratory Analysis</i> 2
	<i>Internal Drainage System</i> 2
	<i>Slope Stability</i> 2
	<i>Maximum Face Slopes</i> 2
Drainage	2
	<i>Top of Fill Drainage</i> 2
	<i>Bench Drainage</i> 2
Placement Requirements	2
	<i>Clearing</i> 2
	<i>Foundation Preparation</i> 2
	<i>Placement</i> 3
	<i>Reclamation</i> 3
Construction Control	3
Certification	3
Plans, Design Data and Construction Specification	4
Sediment Control Requirements	4
	<i>Location of Sediment Control Structure</i> 4

## DURABLE ROCKFILLS

### 10.1 DEFINITION

A controlled rockfill across or through the head of a valley or hollow to form a stable, permanent storage space for excess surface mine overburden, (excess spoil shall consist of at least eighty percent (80%) by volume; sandstone, limestone, or other rocks that do not slake in water), known as "Rockfill".

### 10.2 PURPOSE

The rockfill method was developed to improve aesthetics, reduce landslides, allow for full recovery of one or more coal seams and produce rolling land that is suitable for the postmining land use.

This method provides permanent storage space for excess spoil, which is not required to achieve the approximate original contour, to be handled and placed in a controlled manner.

The size of the selected hollow must be such that the excess overburden generated by the mining operation will be utilized in the fill.

Instead of unstable outslope with its potential for slides and erosion, or islands of isolated land with no access, a large, stable, fairly level area can be constructed with this method.

### 10.3 LOCATION

The rockfill area shall be located on the most moderate slopes and naturally stable areas available.

### 10.4 GENERAL REQUIREMENTS

Special excess spoil fill placement by dumping in a single lift may be approved based upon specific site conditions, provided that the excess spoil fill consists of at least eighty percent (80%) by volume; sandstone, limestone or other durable rocks that do not slake in water. Any such fill must be designed by a Registered Professional Engineer experienced in the design and construction of earth and rockfill embankments.

### 10.5 STABILITY

#### 10.5.1 SURFACE EVALUATION

A field evaluation shall be conducted to locate springs, seeps, mine drainage, deep soil deposits, landslides, etc. which could adversely affect the stability of the proposed fill area and drainage structures.

#### 10.5.2 SUBSURFACE INVESTIGATION

A geotechnical investigation shall be conducted to define type and quantity of rock and soil to be placed in the fill, depth and types of soil in the foundation of the proposed fill, determination of groundwater location, a soil profile for critical locations in the foundation material and material sampling for laboratory analysis. The number, location and depth of borings, test pits and trenches shall be reasonable for the size and location of the structure.

### 10.5.3 LABORATORY ANALYSIS

Laboratory tests shall be conducted on representative on-site foundation and fill materials to include rock and soil classification, soil density, soil water content, permeability and slake durability.

### 10.5.4 INTERNAL DRAINAGE SYSTEM

An internal drainage system shall be designed based upon measured or anticipated flows from all springs, seeps and mine drainage or natural water courses in the fill area. This drain shall be composed of nontoxic, non-acid producing durable rock and shall be free of coal, clay or shale.

### 10.5.5 SLOPE STABILITY

The fill shall be designed for a minimum static factor of safety of 1.5.

### 10.5.6 MAXIMUM FACE SLOPES

The finished slope shall be no steeper than 2 horizontal to 1 vertical and shall contain at least one 20-foot minimum width bench or greater as approved by the Director of the Department of Environmental Protection Mining and Reclamation for every 50 feet in vertical intervals.

## 10.6 DRAINAGE

### 10.6.1 TOP OF FILL DRAINAGE

The top of the fill shall be appropriately graded and sloped to prohibit unplanned impoundment of water and minimize erosion. Fill settlement, movement and type of material should be considered in the determination of these final grades and slopes. The top of the fill may be drained to either a center drain or edge ditches both designed to pass a 100-year, 24-hour storm.

An edge ditch is defined as a ditch located around the periphery of the fill and constructed between natural ground and the fill disposal area.

All ditches shall have considered permanent channel protection based upon design flow velocities.

### 10.6.2 BENCH DRAINAGE

Benches in the face of the fill shall be sloped towards the fill area normal to such with a 3 to 5% slope.

## 10.7 PLACEMENT REQUIREMENTS

### 10.7.1 CLEARING

All woody vegetation shall be cut and removed prior to filling. Incremental clearing methods are required so that existing vegetation is left in place as long as possible to prevent erosion.

### 10.7.2 FOUNDATION PREPARATION

Any keyways, internal drainage systems, toe buttresses or similar structures as provided for in approved pre-plan shall be completed prior to fill placement.

### 10.7.3 PLACEMENT

Rockfill should be placed using a multi-lift method of construction. The maximum lift height should be fifty feet. Dumping shall begin at the head of the hollow and progress down the hollow in a concave configuration maximizing the segregation process to ensure that a blanket of large durable rock is formed on the valley floor. Multi-lifts can be constructed concurrently as long as the initial lower lift is ahead of the proceeding one.

### 10.7.4 RECLAMATION

Slopes shall be covered with topsoil and shall be seeded and mulched immediately as each lift is completed in accordance with the approved revegetation plan.

## 10.8 CONSTRUCTION CONTROL

1. A Registered Professional Engineer shall be retained at the site during construction to supervise the operation in accordance with the approved plan.
2. The fill and drainage system shall be inspected at least weekly for factors which affect the stability of the fill and performance of drainage structures.
3. If a hazardous condition is detected such as potential failure of the fill or failure of the drainage system, the department shall be immediately informed. Immediate action shall be taken to alleviate the hazardous condition.
4. The fill placement operation shall be certified every ninety (90) days of operation as to whether the work is being done in accordance with the approved plan and at the completion of the fill.

## 10.9 CERTIFICATION

Certification of the fill shall be as follows:

1. The fill shall be designed using recognized professional standards and certified by an approved registered professional engineer.
2. The fill shall be inspected for stability by an approved registered professional engineer experienced in the construction of earth and rock fills approved by the Director of the Department of Environmental Protection Mining and Reclamation, throughout construction and during the critical construction periods. After completion of the inspection by the approved Registered Professional Engineer or approved qualified professional specialist, a certified report shall be submitted to the Division of Mining and Reclamation within 2 weeks after conducting the inspection. A copy of the certified report shall be maintained at the mine site.
3. Upon completion of the valley fill, a MR-13 (Certification form) shall be completed and submitted to the Division of Mining and Reclamation.

## 10.10 PLANS, DESIGN DATA AND CONSTRUCTION SPECIFICATION

1. A profile view of the rockfill showing the original ground line as surveyed with 100 foot stations and proposed construction limits.
2. A cross-section located through the midpoint of a bench and the top of the proposed rockfill showing the original ground line as surveyed and proposed construction limits.
3. Stability requirements, submit the following data:
  - a. Surface Evaluation
  - b. Subsurface Investigation
  - c. Laboratory Analysis
  - d. Slope Stability
4. Drainage designs for the following:
  - a. Bench and Edge Ditches
  - b. Diversion Ditches
  - c. Internal Drainage System
5. Sequence of Construction
6. Sequence of Certification of Drainage
  - a. Site Preparation
  - b. Placement of Overburden
  - c. Drainage Systems
  - d. Operation Current - Each proposal shall contain a contingency plan in the event the original design volume is not achieved.
  - e. Reclamation

## 10.11 SEDIMENT CONTROL REQUIREMENTS

Sediment control structures shall have the capacity to store 0.125 ac. ft./acre of sediment for each acre of disturbance in the fill area as well as the mining operation above the fill, for which sediment control is not otherwise provided.

### 10.11.1 LOCATION OF SEDIMENT CONTROL STRUCTURE

All sediment control structures for fill areas shall be close or adjacent to the fill area but not in such proximity so as to affect mass stability.

# 11

# Diversions

## CONTENTS

Definition	1
Purpose	1
Scope	1
Design Criteria	1
<i>Capacity</i>	1
<i>Velocity</i>	1
<i>Design</i>	2
<i>Cross-Section</i>	3
<i>Grade</i>	3
<i>Location</i>	3
<i>Protection Against Sedimentation</i>	3
<i>Outlets</i>	3
<i>Excess Excavated Material</i>	4
Maintenance	4
Plans, Design Data and Specification	4
Construction Specifications	4
<i>Site Preparation</i>	4
<i>Excavating and Shaping</i>	5
<i>Installation of Fiber Mulches, Mulch Blankets, or Nettings, If Applicable</i>	5
<i>Protection Against Erosion</i>	5
Exhibit 11-1	6
Exhibit 11-2	7
Exhibit 11-3	8

## DIVERSIONS

### 11.1 DEFINITION

A graded channel constructed across the slope with or without a supporting ridge on the lower side to divert water of runoff from one area to another.

### 11.2 PURPOSE

1. To divert runoff away from surface mining operations and thereby reducing the volume of water to be treated and to prevent or remove water form contact with acid forming and toxic forming materials.
2. To direct runoff from disturbed areas to sediment structures.

### 11.3 SCOPE

This chapter establishes the minimum acceptable quality for the design and construction of diversions located in predominantly rural or agricultural areas in West Virginia.

All diversions shall be designed, constructed, and maintained in a manner which prevents additional contributions of suspended solids to stream flow and to runoff outside permit area to the extent possible using the best technology currently available.

Diversions shall not be located so as to increase the potential for landslides. Also, diversions shall not be constructed on existing landslides unless approved by the Department of Environmental Protection Mining and Reclamation.

### 11.4 DESIGN CRITERIA

#### 11.4.1 CAPACITY

Diversion shall have the capacity to pass safely the peak discharge from the contributing watershed from a 10-year, 24-hour precipitation event. In determining required peak discharge, see Chapter 2, "Estimating Runoff".

#### 11.4.2 VELOCITY

Diversions should be tailored to fit the conditions of a particular field and local soil type(s). The velocities shall be kept as such as will be safe for the planned type of cover and the expected maintenance schedule. Maximum permissible velocities of flow shall be as follows:

TABLE 11-1  
MAXIMUM PERMISSIBLE VELOCITIES  
FEET PER SECOND

Soil Texture	As-built Channel	Vegetated Channel	Rock Riprap
Sandy, Silt Loam & Silty Loam	1.5	2.5	12
Silty Clay Loam & Sandy Clay Loam	2.0	3.5	12
Clay	2.5	4.5	12

As-built channel is a diversion constructed in earth which will be seeded and mulched immediately after completion.

Vegetated channel is a diversion constructed in earth which will be seeded and mulched immediately after completion with utilization of fiber mulches, mulch blankets or nettings, see Chapter 19, "Water Management Practices", or the establishment of permanent vegetated cover prior to utilization of channel as approved by the Division of Mining and Reclamation.

Rock riprap, when required, will be placed in accordance with the standard and specifications for rock riprap as outlined in Chapter 19, "Water Management Practices".

### 11.4.3 DESIGN

#### 11.4.3.1 PARABOLIC DIVERSION

Exhibit 11-3 will be used to proportion parabolic diversions when the grade of the diversion lies between 0.25% through 10.0%. It is recommended not to exceed an original ground slope of fifteen percent (15%) in utilizing this type of diversion.

#### 11.4.3.2 TRIANGULAR AND TRAPEZOIDAL DIVERSION

When the grade of the diversion is between zero percent (0%) through twenty percent (20%) the design shall be in accordance to the following references:

1. National Engineering Handbook, Chapter 5, U.S. Department of Agriculture, Natural Resources Conservation Service.
2. Erosion and Sediment Control Handbook for Developing Areas West Virginia, U.S. Department of Agriculture, Soil Conservation Service.
3. Brater, E. F. and King, H. W., Handbook of Hydraulics, Sixth Edition. Newer edition (8)

4. Gain, E. W., Engineering Field Manual, Natural Resources Conservation Service. and any other standard engineering practices as approved.

The computation shall indicate Q (peak discharge, in cfs), z (side slopes), n (Mannings Number), b (bottom width), and s (slopes) which then will indicate d (depth, in feet), v (velocity, in feet/sec.).

It is recommended not to exceed an original ground slope of twenty-five percent (25%) in utilizing and constructing this type of diversion unless it can be shown that the complete diversion will be constructed in durable rock, then a greater slope may be approved.

It is recommended not to exceed an original ground slope of twenty-five (25%) in utilizing the type of diversion unless it can be shown that the complete diversion will be constructed in durable rock, then a greater slope may be approved.

#### 11.4.4 CROSS-SECTION

The channel shall be approximately parabolic, triangular or trapezoidal with side slopes no steeper than 1.5:1. When a ridge is used, it shall have a minimum width of 4 feet at the design water elevation. All diversion ditches must provide a minimum of 0.5 feet for freeboard and settlement above the design water elevation.

Protection shall be provided for transition of flows and for critical areas such as swales and curves. Typical cross sections are shown in Exhibit 11-2.

#### 11.4.5 GRADE

Channel grades may be uniform or variable. The allowable velocity for the particular soil type and vegetal cover will determine the maximum grade.

#### 11.4.6 LOCATION

Diversion location shall be determined by outlet conditions, topography, land use, soil type, and length of slope. If the diversion is proposed to divert runoff from disturbed areas to sediment structures, then channels shall be located as near to the disturbance as possible.

#### 11.4.7 PROTECTION AGAINST SEDIMENTATION

When movement of sediment into the channel is a significant problem, a vegetated filter strip shall be used above the diversion.

#### 11.4.8 OUTLETS

Diversions must have adequate outlets that will convey runoff without causing damaging erosion. The outlets may be a natural drainway, grassed waterways, grade stabilization structures, stable watercourses, energy dissipaters or other approved methods of the Department of Environmental Protection Mining and Reclamation. In all cases, the outlets must convey runoff to a point where outflow will not cause damage.

Vegetative outlets shall be installed prior to diversion construction, if needed, to insure establishment of vegetation cover in the outlet channels.

#### 11.4.9 EXCESS EXCAVATED MATERIAL

All excavated material incurred in the construction of a diversion which is not necessary for diversion geometry or regrading of the channel shall be disposed in accordance to sections of Excess Spoil Disposal of the rules and regulations.

### 11.5 MAINTENANCE

The success or failure of a properly designed and constructed diversion depends on two things; the outlets and proper maintenance. All pre-plans must include a detailed maintenance schedule and procedures for initiating the maintenance schedule. The vegetation on the diversion and filter strip should receive regular treatments of fertilizer to maintain good growth. If excessive scouring or erosion occurs, the ditch shall immediately be placed with rock riprap or placement of jute netting in accordance to Chapter 19, "Water Management Practices".

All diversions shall be kept free of sediment and other debris so that the flow of water will remain uninterrupted.

### 11.6 PLANS, DESIGN DATA AND SPECIFICATION

In addition to the "Proposed Drainage Plan", there shall also be submitted the following items concerning diversions:

1. A "Diversion Design Computation Sheet" to be completed for each proposed diversion. See Exhibit 11-1.
2. Construction plans showing:
  - a. A surveyed profile along the centerline of the diversion showing original ground line and proposed diversion bottom.
  - b. Channel cross section showing the original ground line, bottom width, side slopes, depth of flow, freeboard and other pertinent information. Drawn to scale.
  - c. Type of soil in which diversion will be excavated. The soil shall be sampled and classified.
  - d. Type and design, if applicable, the outlet proposed for each diversion.
3. Maintenance schedule and procedures for maintenance.
4. Construction and vegetation specifications.

### 11.7 CONSTRUCTION SPECIFICATIONS

#### 11.7.1 SITE PREPARATION

Obstructions will be removed, as necessary, for construction of the diversion.

### 11.7.2 EXCAVATING AND SHAPING

The completed diversion shall conform to the line, grade, and cross-section as shown on the plans. The top of the constructed ridge or low bank shall not be lower at any point than the designed elevation, including freeboard and the settlement factor. The constructed channel shall be generally free draining, and low spots shall not exceed 0.2 feet in depth. All portions of the diversion shall be finished and smoothed as needed for the establishment of vegetative cover.

### 11.7.3 PROTECTION AGAINST EROSION

The completed diversion shall be seeded and mulched immediately after construction in accordance with Chapter 20 of this handbook for revegetation.

**EXHIBIT 11-1**

**DIVERSION DESIGN COMPUTATION SHEET**

LINE	STATIONS	SOIL TYPE	DRAIN AREA (AC)	REQ'D. CAP. (cfs)	GRADE (%)	TYPE OF DITCH	DIMENSIONS			SIDE SLOPES	AVAIL. CAP. (cfs)	VELOCITY	
							DEPTH (ft.)	BOTTOM (ft.)	TOP WIDTH (ft.)			DESIGN (ft./sec.)	ALLOW. (ft./sec.)

**SEEDING**

MATERIALS	KIND	RATE	TOTAL (lbs.)
SEED			
FERTILIZER			
LIME			
MULCH			

EXHIBIT 11-2

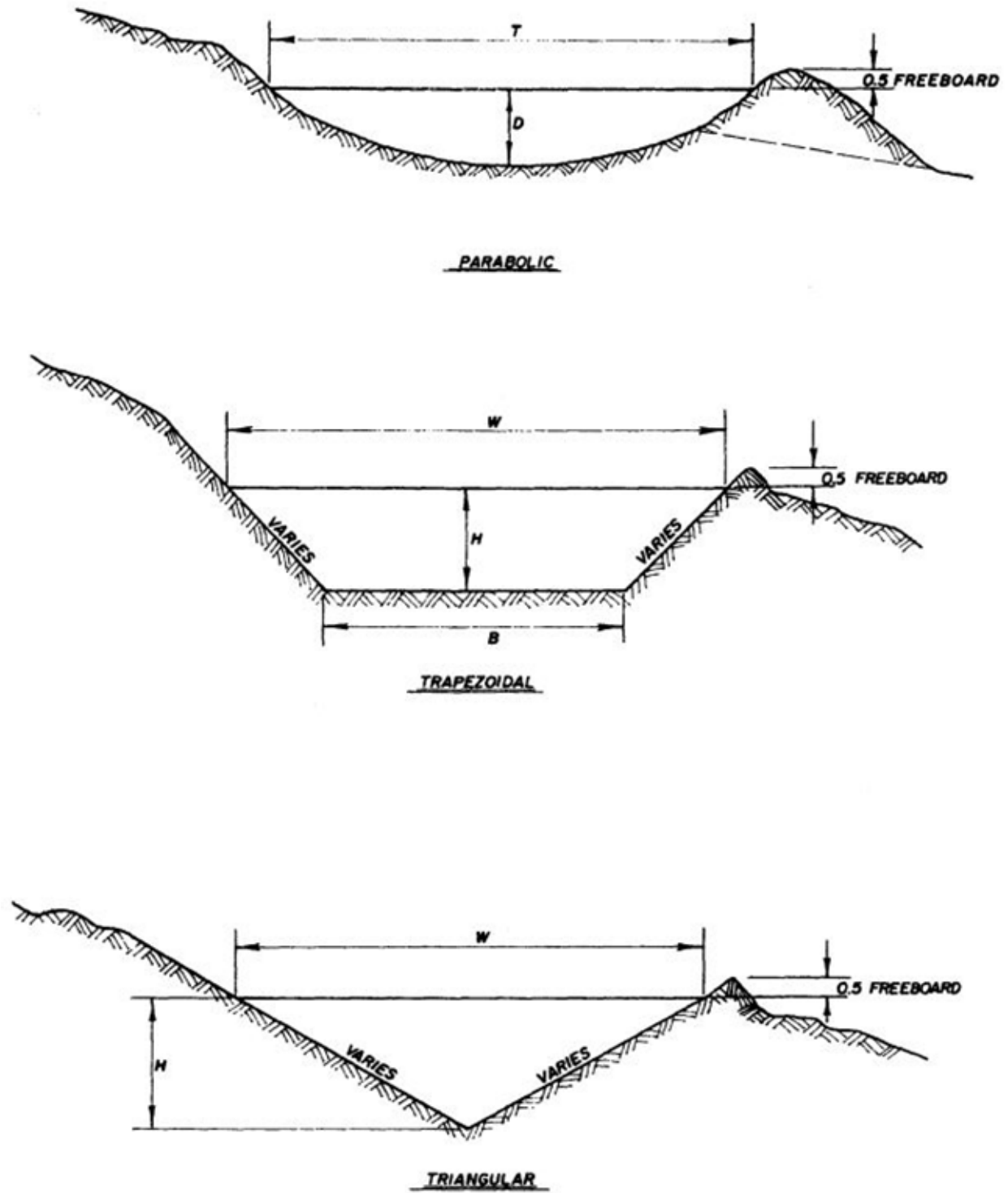

**DIVERSION DITCHES**

**EXHIBIT 11-3**

**PARABOLIC DIVERSION 3**

GRADE %	Q cfs	V = 2.0		V = 2.5		V = 3.0		V = 3.5		V = 4.0		V = 4.5		V = 5.0		V = 5.5		V = 6.0		
		T	D	T	D	T	D	T	D	T	D	T	D	T	D	T	D	T	D	
.25	15																			
	20																			
	25	10	2.4																	
	30	11	2.3																	
	35	13	2.3																	
	40	15	2.3	10	2.7															
	45	17	2.2	12	2.6															
	50	19	2.2	13	2.6															
	55	20	2.2	14	2.6															
	60	22	2.2	15	2.5															
	65	24	2.2	17	2.5															
70	26	2.2	18	2.5	13	3.1														
75	28	2.2	19	2.5	13	3.0														
80	29	2.2	20	2.5	14	3.0														
90	33	2.2	23	2.5	16	3.0														
100	38	2.2	25	2.5	18	3.0														
.50	15	9	1.6																	
	20	11	1.6																	
	25	14	1.6	9	1.9															
	30	17	1.6	11	1.9	8	2.2													
	35	20	1.6	12	1.9	9	2.1													
	40	22	1.6	14	1.8	11	2.1													
	45	25	1.5	16	1.8	12	2.0													
	50	28	1.5	18	1.8	13	2.0	10	2.4											
	55	31	1.5	19	1.8	15	2.0	11	2.4											
	60	33	1.5	21	1.8	16	2.0	11	2.4											
	65	36	1.5	23	1.8	17	2.0	12	2.4											
	70	39	1.5	24	1.8	18	2.0	13	2.3											
	75	42	1.5	26	1.8	20	2.0	14	2.3	11	2.7									
	80	44	1.5	28	1.8	21	2.0	15	2.3	12	2.7									
	90	50	1.5	31	1.8	24	2.0	17	2.3	13	2.7									
100	55	1.5	35	1.8	26	2.0	19	2.3	15	2.6	12	3.0								

Q = Flow in Cubic Feet per second    V = Velocity in Feet per Second    T = Top Width in Feet  
 D = Depth in Feet

PARABOLIC DIVERSION 3

GRADE %	Q cfs	V = 2.0		V = 2.5		V = 3.0		V = 3.5		V = 4.0		V = 4.5		V = 5.0		V = 5.5		V = 6.0	
		T	D	T	D	T	D	T	D	T	D	T	D	T	D	T	D	T	D
.75	15	12	1.3	7	1.6														
	20	16	1.3	9	1.5														
	25	19	1.3	11	1.5	8	1.7												
	30	23	1.3	13	1.5	10	1.7	8	1.9										
	35	27	1.3	15	1.5	11	1.7	9	1.9										
	40	31	1.3	18	1.5	13	1.7	10	1.9										
	45	35	1.3	20	1.5	14	1.7	11	1.8										
	50	38	1.3	22	1.5	16	1.6	13	1.8	9	2.2								
	55	42	1.3	24	1.5	18	1.6	14	1.8	10	2.1								
	60	46	1.3	26	1.5	19	1.6	15	1.8	11	2.1								
	65	50	1.3	28	1.5	21	1.6	16	1.8	12	2.1	10	2.1						
	70	53	1.3	30	1.5	22	1.6	17	1.8	13	2.1	11	2.4						
	75	57	1.3	33	1.5	24	1.6	19	1.8	14	2.1	11	2.3						
80	61	1.3	35	1.5	25	1.6	20	1.8	15	2.1	12	2.3							
90	68	1.3	39	1.5	28	1.6	22	1.8	16	2.1	13	2.3	11	2.6					
100	76	1.3	43	1.5	32	1.6	25	1.8	18	2.1	15	2.3	12	2.6					
1.00	15	13	1.1	8	1.3														
	20	18	1.1	11	1.3	8	1.5												
	25	22	1.1	14	1.3	9	1.5	8	1.6										
	30	27	1.1	17	1.3	11	1.5	9	1.6										
	35	31	1.1	19	1.3	13	1.5	11	1.6	8	1.8								
	40	35	1.1	22	1.3	15	1.4	12	1.6	9	1.8								
	45	40	1.1	25	1.3	17	1.5	13	1.6	10	1.8								
	50	44	1.1	28	1.3	19	1.4	15	1.6	11	1.8	9	2.0						
	55	48	1.1	30	1.3	20	1.4	16	1.5	12	1.8	10	2.0						
	60	53	1.1	33	1.3	22	1.4	18	1.5	14	1.7	10	2.0						
	65	57	1.1	36	1.3	24	1.4	19	1.5	15	1.7	11	2.0	9	2.2				
	70	61	1.1	38	1.3	26	1.4	21	1.5	16	1.7	12	2.0	10	2.2				
	75	66	1.1	41	1.3	28	1.4	22	1.5	17	1.7	13	2.0	11	2.2				
80	70	1.1	44	1.3	29	1.4	24	1.5	18	1.7	14	2.0	11	2.2					
90	79	1.1	49	1.3	33	1.4	27	1.5	20	1.7	15	1.9	13	2.2	11	2.4			
100	87	1.1	55	1.3	37	1.4	29	1.5	22	1.7	17	1.9	14	2.2	12	2.4			

Q = Flow in Cubic Feet per second V = Velocity in Feet per Second  
 D = Depth in Feet T = Top Width in Feet

PARABOLIC DIVERSION 3

GRADE %	Q cfs	V = 2.0		V = 2.5		V = 3.0		V = 3.5		V = 4.0		V = 4.5		V = 5.0		V = 5.5		V = 6.0	
		T	D	T	D	T	D	T	D	T	D	T	D	T	D	T	D	T	D
1.25	15	15	1.0	10	1.2	7	1.4												
	20	20	1.0	13	1.1	9	1.3	7	1.5										
	25	25	1.0	16	1.1	11	1.3	8	1.5	7	1.6								
	30	31	1.0	19	1.1	13	1.3	10	1.4	8	1.6								
	35	36	1.0	23	1.1	15	1.3	11	1.4	9	1.6	7	1.8						
	40	41	1.0	26	1.1	17	1.3	13	1.4	11	1.6	8	1.8						
	45	46	1.0	29	1.1	19	1.3	14	1.4	12	1.5	9	1.7						
	50	50	1.0	32	1.1	21	1.3	16	1.4	13	1.5	10	1.7	8	2.0				
	55	55	1.0	35	1.1	23	1.3	18	1.4	14	1.5	11	1.7	9	1.9				
	60	60	1.0	38	1.1	26	1.3	19	1.4	16	1.5	12	1.7	10	1.9				
	65	65	1.0	41	1.1	28	1.3	21	1.4	17	1.5	13	1.7	11	1.9	9	2.2		
	70	70	1.0	45	1.1	30	1.3	22	1.4	18	1.5	14	1.7	11	1.9	9	2.2		
	75	75	1.0	48	1.1	32	1.3	24	1.4	19	1.5	15	1.7	12	1.9	10	2.1		
	80	80	1.0	51	1.1	34	1.3	25	1.4	21	1.5	16	1.7	13	1.9	11	2.1	9	2.3
	90	90	1.0	57	1.1	38	1.3	29	1.4	23	1.5	18	1.7	15	1.9	12	2.1	10	2.3
100	100	1.0	63	1.1	42	1.3	32	1.4	26	1.5	20	1.7	16	1.9	13	2.1	11	2.3	
1.50	15	17	0.9	11	1.1	8	1.2												
	20	23	0.9	15	1.0	10	1.2	7	1.4	6	1.5								
	25	28	0.9	19	1.0	12	1.2	9	1.4	7	1.5								
	30	34	0.9	22	1.0	15	1.2	10	1.3	8	1.5	7	1.6						
	35	40	0.9	26	1.0	17	1.1	12	1.3	10	1.4	8	1.6						
	40	45	0.9	30	1.0	20	1.2	14	1.3	11	1.4	9	1.6	7	1.8				
	45	51	0.9	33	1.0	22	1.1	15	1.3	12	1.4	10	1.5	8	1.8				
	50	56	0.9	37	1.0	25	1.1	17	1.3	14	1.4	11	1.5	9	1.8				
	55	62	0.9	41	1.0	27	1.1	19	1.3	15	1.4	12	1.5	10	1.7	8	1.9		
	60	67	0.9	44	1.0	30	1.1	20	1.3	16	1.4	14	1.5	11	1.7	9	1.9		
	65	73	0.9	48	1.0	32	1.1	22	1.3	18	1.4	15	1.5	11	1.7	10	1.9		
	70	78	0.9	51	1.0	34	1.1	24	1.3	19	1.4	16	1.5	12	1.7	10	1.9	9	2.1
	75	83	0.9	55	1.0	37	1.1	25	1.3	21	1.4	17	1.5	13	1.7	11	1.9	9	2.1
	80	89	0.9	59	1.0	39	1.1	27	1.3	22	1.4	18	1.5	14	1.7	12	1.9	10	2.1
	90	100	0.9	66	1.0	44	1.1	30	1.3	25	1.4	20	1.5	16	1.7	13	1.9	11	2.0
100	111	0.9	73	1.0	49	1.1	33	1.3	27	1.4	22	1.5	17	1.7	15	1.9	12	2.0	

Q = Flow in Cubic Feet per second    V = Velocity in Feet per Second    T = Top Width in Feet  
D = Depth in Feet

PARABOLIC DIVERSION 3

GRADE %	Q cfs	V = 2.0		V = 2.5		V = 3.0		V = 3.5		V = 4.0		V = 4.5		V = 5.0		V = 5.5		V = 6.0	
		T	D	T	D	T	D	T	D	T	D	T	D	T	D	T	D	T	D
1.75	15	19	0.9	12	1.0	9	1.1	6	1.3										
	20	25	0.9	16	1.0	11	1.1	8	1.3	7	1.3								
	25	31	0.9	20	1.0	14	1.1	10	1.2	8	1.3	7	1.5						
	30	37	0.9	24	1.0	17	1.1	12	1.2	10	1.3	8	1.4						
	35	43	0.9	28	1.0	20	1.1	13	1.2	11	1.3	9	1.4	7	1.6				
	40	49	0.9	32	1.0	22	1.1	15	1.2	13	1.3	10	1.4	8	1.6				
	45	55	0.9	36	1.0	25	1.1	17	1.2	14	1.3	12	1.4	9	1.6	8	1.7		
	50	61	0.9	40	1.0	28	1.1	19	1.2	16	1.3	13	1.4	10	1.4	8	1.7		
	55	67	0.9	44	1.0	31	1.1	21	1.2	17	1.3	14	1.4	11	1.5	9	1.7	8	1.9
	60	73	0.9	48	1.0	33	1.1	23	1.2	19	1.3	15	1.4	12	1.5	10	1.7	8	1.9
	65	78	0.9	52	1.0	36	1.1	25	1.2	21	1.3	17	1.4	13	1.5	11	1.7	9	1.9
	70	84	0.9	56	1.0	39	1.1	27	1.2	22	1.3	18	1.4	14	1.5	12	1.7	10	1.9
	75	90	0.9	59	1.0	42	1.1	29	1.2	24	1.3	19	1.4	15	1.5	12	1.7	10	1.9
	80	96	0.9	63	1.0	44	1.1	30	1.2	25	1.3	20	1.4	16	1.5	13	1.7	11	1.9
90	108	0.9	71	1.0	50	1.1	34	1.2	28	1.3	23	1.4	18	1.5	15	1.7	12	1.9	
100	120	0.9	79	1.0	55	1.1	38	1.2	31	1.3	25	1.4	20	1.5	16	1.7	13	1.9	
2.00	15	21	0.8	13	0.9	9	1.0	7	1.2										
	20	28	0.8	17	0.9	12	1.0	9	1.1	7	1.3	5	1.4						
	25	35	0.8	21	0.9	15	1.0	11	1.1	8	1.3	7	1.4						
	30	41	0.8	26	0.9	18	1.0	13	1.1	10	1.2	8	1.3	7	1.5				
	35	48	0.8	30	0.9	22	1.0	15	1.1	11	1.2	9	1.3	8	1.5				
	40	55	0.8	34	0.9	25	1.0	18	1.1	13	1.2	11	1.3	9	1.5	7	1.7		
	45	62	0.8	38	0.9	28	1.0	20	1.1	14	1.2	12	1.3	10	1.4	8	1.6		
	50	68	0.8	42	0.9	31	1.0	22	1.1	16	1.2	13	1.3	11	1.4	9	1.6	8	1.7
	55	75	0.8	46	0.9	34	1.0	24	1.1	17	1.2	14	1.3	12	1.4	10	1.6	8	1.7
	60	82	0.8	51	0.9	37	1.0	26	1.1	19	1.2	16	1.3	13	1.4	11	1.6	9	1.7
	65	88	0.8	55	0.9	40	1.0	28	1.1	21	1.2	17	1.3	14	1.4	11	1.6	10	1.7
	70	95	0.8	59	0.9	43	1.0	30	1.1	22	1.2	18	1.3	15	1.4	12	1.6	10	1.7
	75	101	0.8	63	0.9	46	1.0	32	1.1	24	1.2	20	1.3	16	1.4	13	1.6	11	1.7
	80	108	0.8	67	0.9	48	1.0	35	1.1	25	1.2	21	1.3	17	1.4	14	1.6	12	1.7
90	121	0.8	75	0.9	54	1.0	39	1.1	28	1.2	23	1.3	19	1.4	16	1.6	13	1.7	
100	134	0.8	83	0.9	60	1.0	43	1.1	31	1.2	26	1.3	21	1.4	17	1.6	15	1.7	

Q = Flow in Cubic Feet per second    V = Velocity in Feet per Second    T = Top width in Feet  
D = Depth in Feet

PARABOLIC DIVERSION 3

GRADE %	Q cfs	V = 2.0		V = 2.5		V = 3.0		V = 3.5		V = 4.0		V = 4.5		V = 5.0		V = 5.5		V = 6.0		
		T	D	T	D	T	D	T	D	T	D	T	D	T	D	T	D	T	D	
3.0	15	24	0.7	16	0.8	11	0.8	9	0.9	7	1.0	5	1.2							
	20	31	0.7	22	0.8	15	0.8	12	0.9	9	1.0	7	1.1							
	25	39	0.7	27	0.8	19	0.8	15	0.9	11	1.0	8	1.0	6	1.2					
	30	47	0.7	32	0.8	23	0.8	17	0.9	13	1.0	10	1.1	7	1.2	6	1.3			
	35	55	0.7	38	0.8	26	0.8	20	0.9	15	1.0	11	1.1	9	1.2	7	1.2	6	1.4	
	40	62	0.7	43	0.8	30	0.8	23	0.9	17	1.0	13	1.1	10	1.1	8	1.2	7	1.4	
	45	70	0.7	48	0.8	34	0.8	26	0.9	19	1.0	15	1.1	12	1.1	9	1.2	8	1.4	
	50	77	0.7	54	0.8	38	0.8	29	0.9	21	1.0	16	1.1	13	1.1	11	1.2	9	1.3	
	55	85	0.7	59	0.8	41	0.8	32	0.9	23	1.0	18	1.1	14	1.1	12	1.2	9	1.3	
	60	93	0.7	64	0.8	45	0.8	35	0.9	26	1.0	19	1.1	16	1.1	13	1.2	10	1.4	
	65	100	0.7	70	0.8	49	0.8	37	0.9	28	1.0	21	1.1	17	1.1	14	1.2	11	1.3	
	70	107	0.7	74	0.8	52	0.8	40	0.9	30	1.0	22	1.1	19	1.1	15	1.2	12	1.3	
	75	115	0.7	79	0.8	56	0.8	43	0.9	32	1.0	24	1.1	20	1.1	16	1.2	13	1.3	
	80	122	0.7	85	0.8	59	0.8	46	0.9	34	1.0	26	1.1	21	1.1	18	1.2	14	1.3	
90	137	0.7	95	0.8	67	0.8	51	0.9	38	1.0	29	1.1	23	1.1	19	1.2	15	1.3		
100	152	0.7	105	0.8	74	0.8	57	0.9	42	1.0	32	1.1	26	1.1	21	1.2	17	1.3		
4.0	15	28	0.6	20	0.7	14	0.7	10	0.8	8	0.9	6	0.9	5	1.1					
	20	37	0.6	27	0.7	19	0.7	14	0.8	11	0.8	8	0.9	6	1.0	6	1.1			
	25	46	0.6	33	0.7	23	0.7	17	0.8	13	0.8	11	0.9	8	1.0	7	1.1	6	1.2	
	30	55	0.6	40	0.7	28	0.7	20	0.8	16	0.8	13	0.9	10	1.0	8	1.1	7	1.2	
	35	64	0.6	46	0.7	32	0.7	24	0.8	18	0.8	15	0.9	11	1.0	10	1.1	8	1.2	
	40	73	0.6	52	0.7	37	0.7	27	0.8	21	0.8	17	0.9	13	1.0	11	1.0	9	1.1	
	45	82	0.6	59	0.7	41	0.7	30	0.8	23	0.8	19	0.9	14	1.0	12	1.1	10	1.1	
	50	91	0.6	65	0.7	46	0.7	34	0.8	26	0.8	21	0.9	16	1.0	14	1.1	11	1.1	
	55	100	0.6	72	0.7	50	0.7	37	0.8	29	0.8	23	0.9	17	1.0	15	1.0	12	1.1	
	60	109	0.6	78	0.7	55	0.7	40	0.8	31	0.8	25	0.9	19	1.0	16	1.0	13	1.1	
	65	117	0.6	84	0.7	59	0.7	44	0.8	34	0.8	27	0.9	20	1.0	18	1.0	14	1.1	
	70	126	0.6	90	0.7	63	0.7	47	0.8	36	0.8	29	0.9	22	1.0	19	1.0	15	1.1	
	75	135	0.6	97	0.7	68	0.7	50	0.8	39	0.8	31	0.9	24	1.0	20	1.0	17	1.1	
	80	143	0.6	103	0.7	72	0.7	53	0.8	41	0.8	33	0.9	25	1.0	21	1.0	18	1.1	
90	161	0.6	115	0.7	81	0.7	60	0.8	46	0.8	37	0.9	28	1.0	24	1.0	20	1.1		
100	178	0.6	128	0.7	90	0.7	66	0.8	51	0.8	41	0.9	31	1.0	27	1.0	22	1.1		

Q = Flow in Cubic Feet per second    V = Velocity in Feet per Second    T = Top width in Feet  
D = Depth in Feet

PARABOLIC DIVERSION 3

GRADE %	Q cfs	V = 2.0		V = 2.5		V = 3.0		V = 3.5		V = 4.0		V = 4.5		V = 5.0		V = 5.5		V = 6.0	
		T	D	T	D	T	D	T	D	T	D	T	D	T	D	T	D	T	D
5.0	15	29	0.6	21	0.6	15	0.7	12	0.7	9	0.8	7	0.8	6	0.9	5	1.0		
	20	39	0.6	28	0.6	20	0.7	16	0.7	12	0.8	10	0.8	8	0.9	6	1.0	5	1.1
	25	49	0.6	35	0.6	25	0.7	20	0.7	15	0.8	12	0.8	10	0.9	8	1.0	7	1.0
	30	58	0.6	42	0.6	30	0.7	24	0.7	18	0.8	14	0.8	11	0.9	9	1.0	8	1.0
	35	68	0.6	49	0.6	35	0.7	28	0.7	21	0.8	17	0.8	13	0.9	11	0.9	9	1.0
	40	77	0.6	56	0.6	40	0.7	32	0.7	24	0.8	19	0.8	15	0.9	12	0.9	10	1.0
	45	86	0.6	63	0.6	44	0.7	36	0.7	27	0.8	21	0.8	17	0.9	14	0.9	12	1.0
	50	96	0.6	69	0.6	49	0.7	49	0.7	39	0.8	24	0.8	19	0.9	15	0.9	13	1.0
	55	105	0.6	76	0.6	54	0.7	44	0.7	33	0.8	26	0.8	21	0.9	17	0.9	14	1.0
	60	114	0.6	83	0.6	59	0.7	48	0.7	36	0.8	28	0.8	22	0.9	18	0.9	15	1.0
	65	123	0.6	89	0.6	63	0.7	52	0.7	38	0.8	31	0.8	24	0.9	19	0.9	17	1.0
	70	132	0.6	96	0.6	68	0.7	56	0.7	41	0.8	33	0.8	26	0.9	21	0.9	18	1.0
	75	142	0.6	102	0.6	73	0.7	59	0.7	44	0.8	35	0.8	28	0.9	22	0.9	19	1.0
	80	151	0.6	109	0.6	78	0.7	63	0.7	47	0.8	37	0.8	30	0.9	24	0.9	20	1.0
	90	169	0.6	122	0.6	87	0.7	71	0.7	53	0.8	42	0.8	33	0.9	27	0.9	23	1.0
100	187	0.6	136	0.6	97	0.7	79	0.7	59	0.8	47	0.8	37	0.9	30	0.9	26	1.0	
6.0	15	35	0.5	23	0.6	17	0.6	13	0.7	10	0.7	8	0.8	7	0.8	5	0.9	4	1.0
	20	46	0.5	30	0.6	22	0.6	17	0.7	13	0.7	11	0.7	9	0.8	7	0.9	6	1.0
	25	57	0.5	37	0.6	28	0.6	21	0.7	17	0.7	13	0.7	11	0.8	9	0.9	7	0.9
	30	69	0.5	45	0.6	33	0.6	25	0.7	20	0.7	16	0.7	13	0.8	10	0.9	8	0.9
	35	80	0.5	52	0.6	38	0.6	29	0.7	23	0.7	19	0.7	15	0.8	12	0.9	10	0.9
	40	91	0.5	59	0.6	44	0.6	33	0.7	26	0.7	21	0.7	17	0.8	14	0.9	11	0.9
	45	102	0.5	67	0.6	49	0.6	37	0.7	30	0.7	24	0.7	19	0.8	16	0.9	13	0.9
	50	113	0.5	74	0.6	54	0.6	42	0.7	33	0.7	26	0.7	22	0.8	17	0.9	14	0.9
	55	123	0.5	81	0.6	60	0.6	46	0.7	36	0.7	29	0.7	24	0.8	19	0.8	15	0.9
	60	134	0.5	88	0.6	65	0.6	50	0.7	39	0.7	32	0.7	26	0.8	21	0.8	17	0.9
	65	145	0.5	95	0.6	70	0.6	54	0.7	42	0.7	34	0.7	28	0.8	22	0.9	18	0.9
	70	155	0.5	102	0.6	75	0.6	58	0.7	45	0.7	37	0.7	30	0.8	24	0.9	19	0.9
	75	166	0.5	109	0.6	81	0.6	62	0.7	49	0.7	39	0.7	32	0.8	26	0.8	21	0.9
	80	176	0.5	116	0.6	86	0.6	65	0.7	52	0.7	42	0.7	34	0.8	27	0.9	22	0.9
	90	198	0.5	130	0.6	96	0.6	73	0.7	58	0.7	47	0.7	38	0.8	31	0.8	25	0.9
100	219	0.5	144	0.6	107	0.6	81	0.7	64	0.7	52	0.7	42	0.8	34	0.9	28	0.9	

Q = Flow in Cubic Feet per second    V = Velocity in Feet per Second    T = Top Width in Feet  
D = Depth    Feet

PARABOLIC DIVERSION 3

GRADE %	Q cfs	V = 2.0		V = 2.5		V = 3.0		V = 3.5		V = 4.0		V = 4.5		V = 5.0		V = 5.5		V = 6.0	
		T	D	T	D	T	D	T	D	T	D	T	D	T	D	T	D	T	D
8.0	15	37	0.5	27	0.5	19	0.5	15	0.6	12	0.6	9	0.7	8	0.8	6	0.7	5	0.8
	20	49	0.5	35	0.5	25	0.5	20	0.6	16	0.6	13	0.7	10	0.7	9	0.7	7	0.8
	25	61	0.5	44	0.5	31	0.5	25	0.6	19	0.6	16	0.7	13	0.7	11	0.7	9	0.8
	30	73	0.5	53	0.5	37	0.5	30	0.6	23	0.6	19	0.7	16	0.7	13	0.7	11	0.8
	35	85	0.5	61	0.5	43	0.5	35	0.6	27	0.6	22	0.6	18	0.7	15	0.7	12	0.8
	40	97	0.5	70	0.5	49	0.5	40	0.6	31	0.6	25	0.6	21	0.7	17	0.7	14	0.8
	45	109	0.5	78	0.5	55	0.5	45	0.6	35	0.6	28	0.6	23	0.7	19	0.7	16	0.8
	50	120	0.5	87	0.5	61	0.5	50	0.6	38	0.6	31	0.7	26	0.7	21	0.7	17	0.8
	55	132	0.5	95	0.5	67	0.5	55	0.6	42	0.6	34	0.7	28	0.7	23	0.7	19	0.8
	60	143	0.5	103	0.5	73	0.5	60	0.6	46	0.6	37	0.7	31	0.7	25	0.7	21	0.8
	65	155	0.5	111	0.5	79	0.5	65	0.6	50	0.6	40	0.7	33	0.7	27	0.7	23	0.8
	70	166	0.5	120	0.5	85	0.5	69	0.6	53	0.6	43	0.6	36	0.7	29	0.7	24	0.8
	75	177	0.5	128	0.5	91	0.5	74	0.6	57	0.6	46	0.7	38	0.7	31	0.7	26	0.8
	80	188	0.5	136	0.5	96	0.5	79	0.6	61	0.6	49	0.6	41	0.7	33	0.7	28	0.8
90	211	0.5	152	0.5	108	0.6	88	0.6	68	0.6	55	0.7	46	0.7	37	0.7	31	0.8	
100	234	0.5	168	0.5	120	0.6	98	0.6	75	0.6	61	0.7	51	0.7	41	0.7	34	0.8	
10.0	15	45	0.4	33	0.5	23	0.5	17	0.5	13	0.6	11	0.6	9	0.6	7	0.7	6	0.7
	20	60	0.4	43	0.5	30	0.5	22	0.5	18	0.6	14	0.6	12	0.6	10	0.7	8	0.7
	25	75	0.4	54	0.5	38	0.5	28	0.5	22	0.6	18	0.6	15	0.6	12	0.7	10	0.7
	30	89	0.4	64	0.5	45	0.5	33	0.5	27	0.6	21	0.6	18	0.6	15	0.6	12	0.7
	35	104	0.4	75	0.5	53	0.5	38	0.5	31	0.6	25	0.6	21	0.6	17	0.7	14	0.7
	40	118	0.4	85	0.5	60	0.5	44	0.5	35	0.6	28	0.6	24	0.6	20	0.7	16	0.7
	45	132	0.4	95	0.5	67	0.5	49	0.5	40	0.6	32	0.6	27	0.6	22	0.7	18	0.7
	50	146	0.4	105	0.5	74	0.5	54	0.5	44	0.6	35	0.6	30	0.6	24	0.7	20	0.7
	55	160	0.4	115	0.5	82	0.5	60	0.5	48	0.6	39	0.6	32	0.6	27	0.6	22	0.7
	60	174	0.4	124	0.5	87	0.5	65	0.5	52	0.6	42	0.6	35	0.6	29	0.7	24	0.7
	65	188	0.4	135	0.5	96	0.5	70	0.5	57	0.6	45	0.6	38	0.6	32	0.7	26	0.7
	70	201	0.4	145	0.5	103	0.5	75	0.5	61	0.6	49	0.6	41	0.6	34	0.7	28	0.7
	75	215	0.4	155	0.5	110	0.5	80	0.5	65	0.6	52	0.6	44	0.6	36	0.7	30	0.7
	80	228	0.4	164	0.5	116	0.5	85	0.5	69	0.6	55	0.6	47	0.6	39	0.7	32	0.7
90	255	0.4	184	0.5	131	0.5	96	0.5	76	0.6	62	0.6	52	0.6	43	0.7	36	0.7	
100	282	0.4	204	0.5	145	0.5	106	0.5	86	0.6	69	0.6	58	0.6	48	0.7	40	0.7	

Q = Flow in Cubic Feet per second    V = Velocity in Feet per Second    T = Top Width in Feet  
D = Depth in Feet

# *12 Stream Channel Diversion*

## *C O N T E N T S*

Definition	1
Purpose	1
Scope	1
Design Capacity	1
	<i>Capacity</i> 1
	<i>Velocity</i> 1
	<i>Cross Section</i> 2
	<i>Grade</i> 2
	<i>Erosion</i> 2
Temporary Channel Diversion	2
Permanent Channel Diversions	2
Plans, Design Data and Specifications	2

## **STREAM CHANNEL DIVERSION**

### **(STREAM LOCATION)**

#### **12.1 DEFINITION**

A graded temporary or permanent channel constructed to divert flow from a perennial or intermittent stream. The permanent channel is a channel remaining after surface coal mining and reclamation operations are complete and a temporary channel will be used during only surface coal mining and reclamation operations.

#### **12.2 PURPOSE**

To permit relocation of perennial and intermittent stream so as to authorize surface mining activities closer to or through the stream.

#### **12.3 SCOPE**

This chapter establishes the minimum acceptable quality for the design and construction of stream channel diversions in predominantly rural or agricultural areas in West Virginia.

During and after mining, the water quantity and quality from the stream section within 100 feet of the surface mining operation shall not be adversely affected.

The constructed channel shall equally enhance any existing aquatic resource.

#### **12.4 DESIGN CAPACITY**

All applicable sections in Chapter 11, "Diversion", shall apply for stream channel diversion except for the following requirements:

##### **12.4.1 CAPACITY**

The combination of channel bank and floodplain configurations shall be adequate to pass safely the peak runoff of a minimum of a 10-year, 24-hour precipitation event for a temporary stream channel diversion and a 100-year, 24-hour precipitation event for a permanent stream channel diversion. However, the capacity of the permanent stream channel itself may be at least equal to the capacity of the unmodified stream channel immediately upstream and downstream of the proposed diversion, if approved by the Director of the Department of Environmental Protection Mining and Reclamation. In determining required peak discharge, see Chapter 2, "Estimating Runoff".

##### **12.4.2 VELOCITY**

All temporary and permanent stream channel diversions shall be protected with rock riprap in accordance to standard and specifications for rock riprap as outlined in Chapter 19, "Water Management Practices", Section 19.19 or in accordance to Table 11-1 of Chapter 11, if approved by

the Director of the Department of Environmental Protection Mining and Reclamation. The above rock riprap specification allow a maximum permissible velocity of 12 feet per second (fps).

#### 12.4.3 CROSS SECTION

The longitudinal profile of the stream, the channel and the flood-plain shall be designed and constructed to remain stable and to prevent, to the extent possible using the best technology currently available, additional contributions of suspended solids to streamflow or to runoff outside the permit area. These contributions shall not be in excess of requirements of State or Federal law.

#### 12.4.4 GRADE

The average stream gradient shall be maintained and the channel designed, constructed and maintained to remain stable and to minimize additional contributions of suspended solids to stream flow.

#### 12.5 EROSION

Erosion control structures such as retention basins, water management practices and artificial channel roughness structures shall be used in channels only when approved by the Director as being necessary to control erosion.

### 12.6 TEMPORARY CHANNEL DIVERSION

When the channel has achieved its intended purpose, then the channel shall be removed and the affected area regraded and revegetated in accordance to Chapter 20 of this handbook. At the time the channel is removed, downstream water facilities previously protected by the channel shall be modified or removed.

### 12.7 PERMANENT CHANNEL DIVERSIONS

When the permanent channel is constructed or a stream channel is restored after a temporary channel diversion, the operator shall:

1. Restore, enhance where practicable or maintain natural riparian vegetation on the banks of the stream;
2. Establish or restore the stream to its natural meandering shape of an environmentally acceptable gradient, as determined by the Director of the Department of Environmental Protection Mining and Reclamation; and
3. Establish or restore the stream to a longitudinal profile and cross-section, including aquatic habitats (usually a pattern of riffles, pools and drops rather than uniform depth) that approximates premining stream channel characteristics.

### 12.8 PLANS, DESIGN DATA AND SPECIFICATIONS

1. A "stream channel design computation sheet" to be completed for each proposed temporary or permanent stream channel.

2. Construction plans showing:
  - a. A plan view of the area showing centerline surveyed profiles of existing stream channel and proposed location of the temporary or permanent stream channel (drawn to scale).
  - b. Surveyed profiles along the centerline of the existing and temporary or permanent stream channel showing original ground and proposed or existing stream bottom. (drawn to scale)
  - c. A cross-section at 50-foot intervals of the profile showing original ground limits, bottom width, side slopes, depth of flow, flood-plain configuration and etc.
3. Show detailed sequence of installation of temporary or permanent stream channel.
4. Construction specifications.
5. Maintenance schedule and procedures for maintenance.

# 13 *Haulageway or Access Roads*

## *C O N T E N T S*

Definition	1
Purpose	1
Scope	1
Grading	1
	<i>The Grading of the haulageway or access roads shall be such that:</i>
	<i>Road Embankment</i>
Curves	2
Cut Slopes	2
Ditches	2
Culverts	2
Culvert Openings	3
Seeding of Slopes	3
Haulageway or Access Road Surfacing	3
Dust Control	3
Tolerance	3
Removal of Drainage Structures	3
Intermittent or Perennial Stream Crossing	3
Design Criteria for Culverts	4
	<i>Capacity</i>
Sediment Control	4
Type of Culverts Proposed	4
Existing Haulageways or Access Roads	4
Infrequently Used Access Roads	5
Plan Design Data and Construction Specifications	5
Abandonment of Haulageways or Access Roads	5
Exhibit 13-1	7
Exhibit 13-2	8
Exhibit 13-3	9
Exhibit 13-4	10
Exhibit 13-5	11
Table 13-1	12
Figure 13-1	13
Figure 13-2	14

## HAULAGEWAY OR ACCESS ROADS

### 13.1 DEFINITION

Haulageway or access road means any road constructed, improved, maintained or used by the surface mining operation with the exception of state owned and maintained roads.

### 13.2 PURPOSE

To preserve the capacity of reservoirs, ditches, canals, diversions, waterways and streams and to prevent undesirable deposition on bottom lands, in channels or waterways and other areas by providing basins for the deposition and storage of silt, sand, gravel, stone and other sediment.

### 13.3 SCOPE

This chapter establishes the minimum acceptable quality for the design and construction of haulageway or access roads in predominantly rural or agricultural areas in West Virginia.

### 13.4 GRADING

13.4.1 The grading of the haulageway or access roads shall be such that:

1. The overall grades shall not exceed ten percent (10%);
2. The maximum pitch grade shall not exceed fifteen percent (15%) for 300 feet in each 1,000 feet of road construction; and
3. The surface shall pitch toward the ditchline at the minimum rate of 1/2 inch per foot of surface width or crowned at the minimum rate of 1/2 inch per foot of surface width as measured from the centerline of the haulageway or access road.

13.4.2 Road Embankment - Embankment sections shall be constructed in accordance with the following provisions:

1. Where an embankment is to be placed on side slopes exceeding thirty- six percent (36%), the following conditions shall be required:
  - a. All vegetative material and topsoil shall be removed from the embankment foundation to increase stability, and no vegetative material or topsoil shall be placed beneath or in any embankment.
  - b. A keyway cut shall be required at the proposed toe of the fill so as to increase stability; said keyway shall be at a minimum 10 feet in width and shall be sloped inward.
  - c. The embankment shall be constructed in uniform compacted layers not to exceed 24 inches.
  - d. The embankment slopes shall be no steeper than 1.5 horizontal to 1 vertical.

2. Where an embankment is to be placed on side slopes less than thirty-six percent (36%), the following conditions shall be required:
  - a. All vegetative material and topsoil shall be removed from the embankment foundation to increase stability, and no vegetative material or topsoil shall be placed beneath or in any embankment.
  - b. Embankments shall be constructed to conform to compaction, stabilization and controlled placement techniques as required in the rules and regulations.
  - c. The embankment slopes shall be no steeper than 2 horizontal to 1 vertical.

### 13.5 CURVES

The grade on switchback curves shall be reduced to less than the approach grade and should not be greater than ten percent (10%).

### 13.6 CUT SLOPES

Cut slopes should not be more than 1:1 in soils or 1/4:1 in rock.

### 13.7 DITCHES

A ditch shall be provided on both sides of a throughcut and on the inside shoulder of a cutfill sections, with ditch relief culverts being spaced according to grade. Water shall be intercepted or directed around and away from a switchback. All ditchlines shall be designed to pass a peak discharge capacity of a 1-year, 24-hour precipitation event. For design assistance, see Chapter 11, "Diversion".

### 13.8 CULVERTS

Ditch relief culverts shall be installed wherever necessary to insure proper drainage of surface water beneath or through the haulageway or access road, according to the following provisions:

- |                          |                             |
|--------------------------|-----------------------------|
| 1. Road Grade in Percent | Spacing of Culverts in Feet |
| 0-5                      | 300-800                     |
| 6-10                     | 200-300                     |
| 11-15                    | 100-200                     |
2. The culvert shall cross the haulageway or access road at a 30-degree angle downgrade with a minimum grade of three percent (3%) from inlet to outlet, except in intermittent or perennial streams where the pipe shall be straight and coincide with the normal flow;
  3. The inlet end shall be protected by a headwall of stable non-erodible material as approved by the director and the slope at the outlet and shall be protected with an apron of rock riprap, energy dissipator or other material approved by the director;
  4. The culvert shall be covered by compacted fill to a depth of 1 foot or half the culvert diameter, whichever is greater; and

5. Design of culverts may be submitted where the aforementioned design criteria is not practical or necessary.

### **13.9 CULVERT OPENINGS**

Culvert openings installed on haulageways or access roads shall not be less than one hundred (100) square inches in area, but, in any event, all culvert openings shall be adequate to carry storm runoff of peak discharge capacity of a 1-year, 24-hour precipitation event from the contributing watershed and shall receive necessary maintenance to function properly at all times.

### **13.10 SEEDING OF SLOPES**

All disturbed area including fill and cut slopes, shall be seeded and mulched immediately after the construction of a haulageway or access road and maintained thereafter in accordance with Chapter 20 of this handbook for revegetation.

### **13.11 HAULAGEWAY OR ACCESS ROAD SURFACING**

Haulageways or access roads shall not be surfaced with any acid-producing or toxic material or with any material which will produce a concentration of suspended solids in surface drainage.

### **13.12 DUST CONTROL**

All reasonable means shall be employed to control dust from the surface of haulageways or access roads.

### **13.13 TOLERANCE**

All grades referred to in this section shall be subject to a tolerance of two percent (2%) grade. All linear measurements referred to in this section shall be subject to a tolerance of ten of measurement. Angles referred to in this section shall be measured from the horizontal and shall be subject to a tolerance of five percent (5%).

### **13.14 REMOVAL OF DRAINAGE STRUCTURES**

Bridges, culverts, stream crossings, etc., necessary to provide access to the operation, shall not be removed until reclamation is completed and approved by the director. The same precautions as to water quality are to be taken during removal of drainage structures as those taken during construction and use.

### **13.15 INTERMITTENT OR PERENNIAL STREAM CROSSING**

Culverts, bridges or other drainage structures shall be used to cross intermittent or perennial streams. Consideration shall be given to such factors as weather conditions, season of the year, time period for construction, etc., with regard to using measures to minimize adverse effects to the water quality and stream channel. In no event, shall the sediment load of the stream be significantly increased or the water quality be significantly decreased during the construction period. Water control structures shall be designed with a discharge capacity, capacity capable of passing the runoff for a 10-year, 24-hour precipitation event from the contributing watershed.

However, if approved by the director, the capacity of the water control structure itself can be at least equal to or greater than stream channel discharge capacity immediately upstream and downstream of the crossing.

The culvert, whether inlet or outlet control, shall be unsubmerged at the entrance.

## **13.16 DESIGN CRITERIA FOR CULVERTS**

### **13.16.1 CAPACITY**

The size of culverts used shall be adequate to bypass the expected peak discharge from the required frequency storm. The peak discharge shall be obtained from the procedures outlined in Chapter 2, "Estimating Runoff", with the determination of culvert size to be in accordance to Exhibits 13-1 and 13-2, "Inlet Control", and Exhibits 13-3 and 13-4, "Outlet Control."

Inlet control means the discharge capacity of a culvert controlled at a culvert entrance by the depth of the headwater (HW) and the entrance geometry, including the area, shape and type of inlet edge. Type of inlet controlled flow for an unsubmerged and submerged entrance are shown in Figure 13-1.

Outlet control involves the addition and consideration of the elevation of the tailwater in the outlet channel and the slope, roughness and length of the culvert barrel. Types of outlet controlled flow are shown in Figure 13-2.

## **13.17 SEDIMENT CONTROL**

A sediment storage volume must be provided equal to 0.125-acre foot for each acre of disturbed area or a lesser value as approved by the director. Temporary erosion and sedimentation control measures as outlined in Chapter 19 of this handbook shall be implemented during construction until permanent control can be established.

## **13.18 TYPE OF CULVERTS PROPOSED**

In determining the type of culverts to be proposed, the pH of the normal stream flow existing and expected shall be considered, see Chapter 3, Section 3.3.5 for different type of culverts for different levels of pH.

## **13.19 EXISTING HAULAGEWAYS OR ACCESS ROADS**

Where existing roads are to be used for access or haulage and it can be demonstrated that reconstruction to meet the above requirements would result in greater environmental harm and the drainage and sediment control requirements of this section can otherwise be met, Chapter 13.4.1(1) & (2), 13.5, 13.6 and 13.8(1) & (2) will be exempt for these existing roads.

### 13.20 INFREQUENTLY USED ACCESS ROADS

Access roads constructed for and used only to provide infrequent service to surface facilities such as ventilators, monitoring devices and fans shall be exempt from the requirements of the above sections with the exception of Chapters 13.10 and 13.22.

### 13.21 PLAN, DESIGN DATA AND CONSTRUCTION SPECIFICATIONS

1. A plan view drawn to scale showing: haulroad station baseline; location and size of culverts; flow directions; intermittent or perennial streams; and other pertinent data.
2. A surveyed profile drawn to scale (scale should be no greater than 1" = 100' horizontal, 1" = 50' vertical) showing but not limited to: road surface; ditchline; location and size of culverts; station; elevations; original ground; and percent grade.
3. Cross-section of haulroad showing culvert, slope of culvert, fill material, original ground, ditches and sediment control device, if applicable.
4. Intermittent or perennial stream crossings, submit the following:
  - a. Structure computation sheet (Exhibit 13-5)
  - b. Cross-section showing all pertinent information.
5. Maintenance schedule and procedure for maintenance.
6. Construction specification, include a description of the following:
  - a. Site Preparation
  - b. Excavation
  - c. Selection and Placement of Materials
  - d. Vegetative Protection Against Erosion
  - e. Haulageway or Access Road Surfacing
  - f. Erosion and Pollution Control
  - g. Procedures and Timetables for Abandonment

### 13.22 ABANDONMENT OF HAULAGEWAYS OR ACCESS ROADS

Haulageways of access roads shall be abandoned in accordance with the rules and regulations in addition to the following requirements:

1. Upon abandonment of haulageways or access roads, every effort shall be made to prevent erosion by the use of culverts, water bars or other devices. Water bars or earth berms shall be installed according to the following table of spacings in terms of percent of haulageway or access road grade, prior to the abandonment.

PERCENT OF HAULAGEWAY	SPACING OF WATER BARS IN FEET
2	250
5	135
10	80
15	60
20	45
Above 20	25

2. Upon abandonment of haulageway or access roads, they shall be seeded and mulched immediately in accordance with Chapter 20 of the handbook for revegetation.

EXHIBIT 13-1

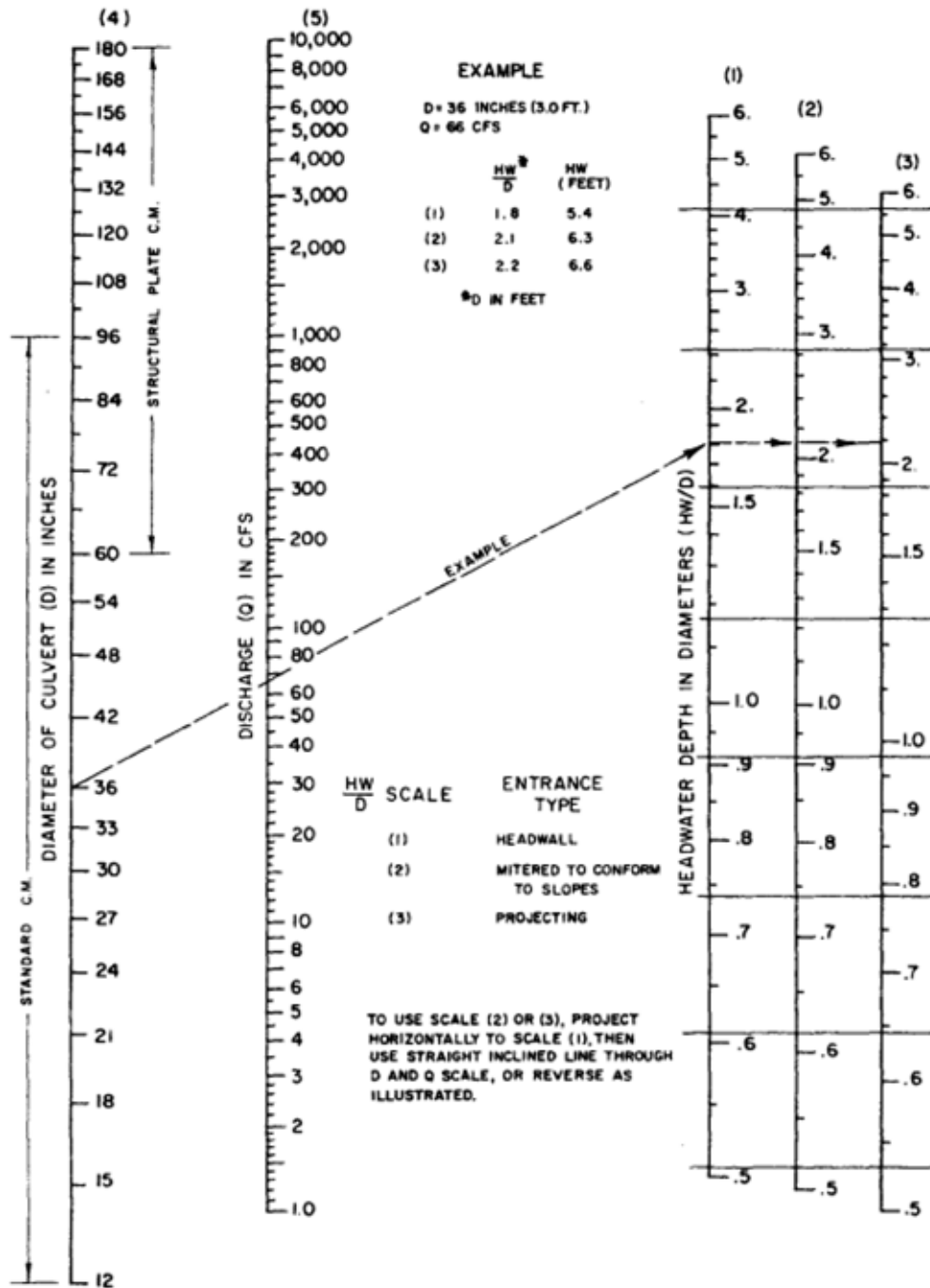

HEADWATER DEPTH FOR CM PIPE CULVERTS WITH INLET CONTROL  
 (REF HYD. ENG. CIR. NO. 5, USBPR, 1965)

EXHIBIT 13-2

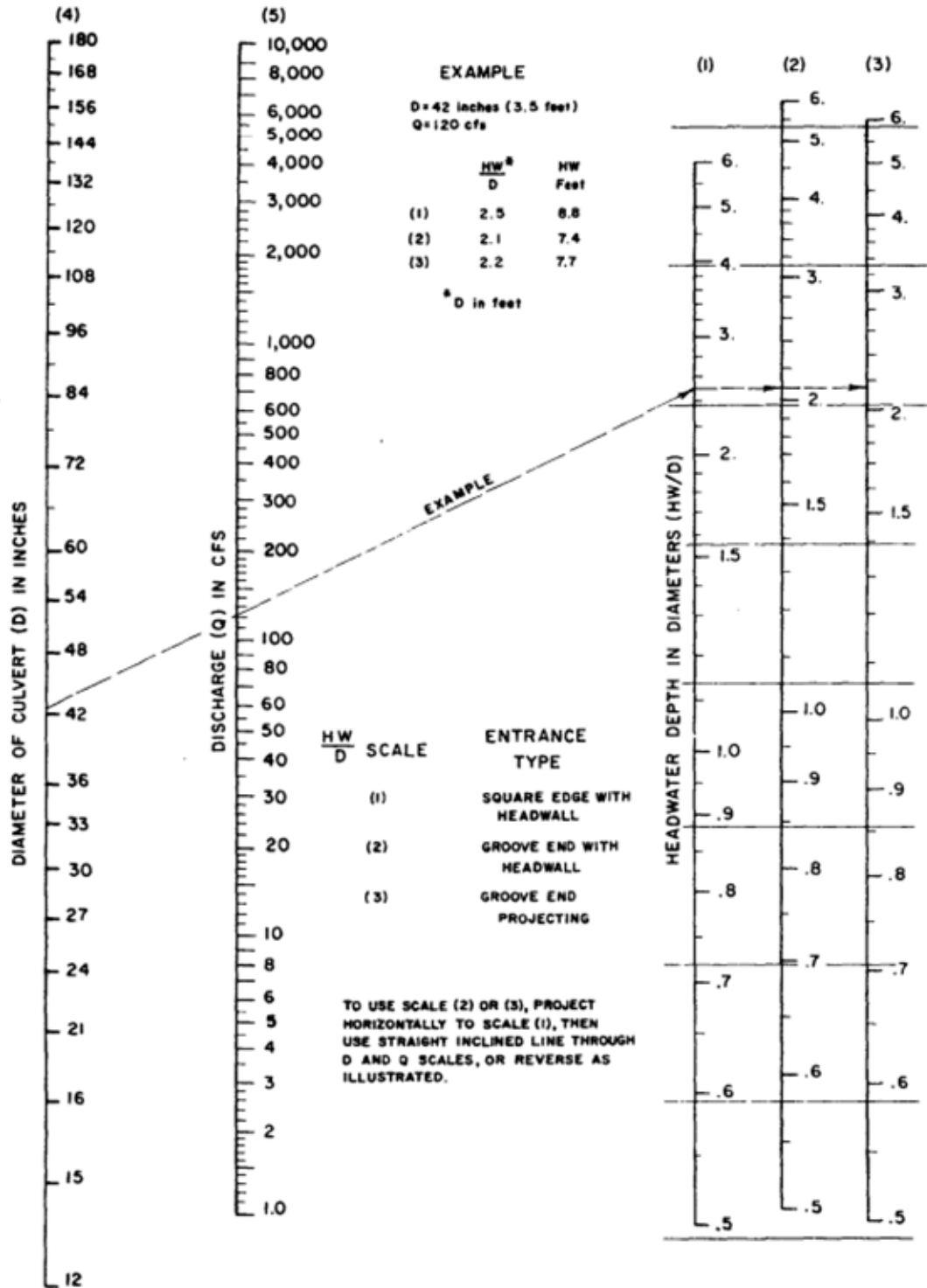

HEADWATER DEPTH FOR CONCRETE PIPE CULVERTS WITH INLET CONTROL  
 (REF. HYD. ENG. CIR. NO.5, USBPR, 1965)

EXHIBIT 13-3

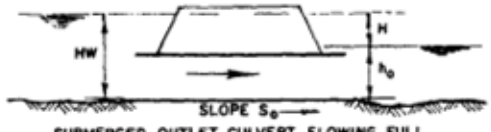
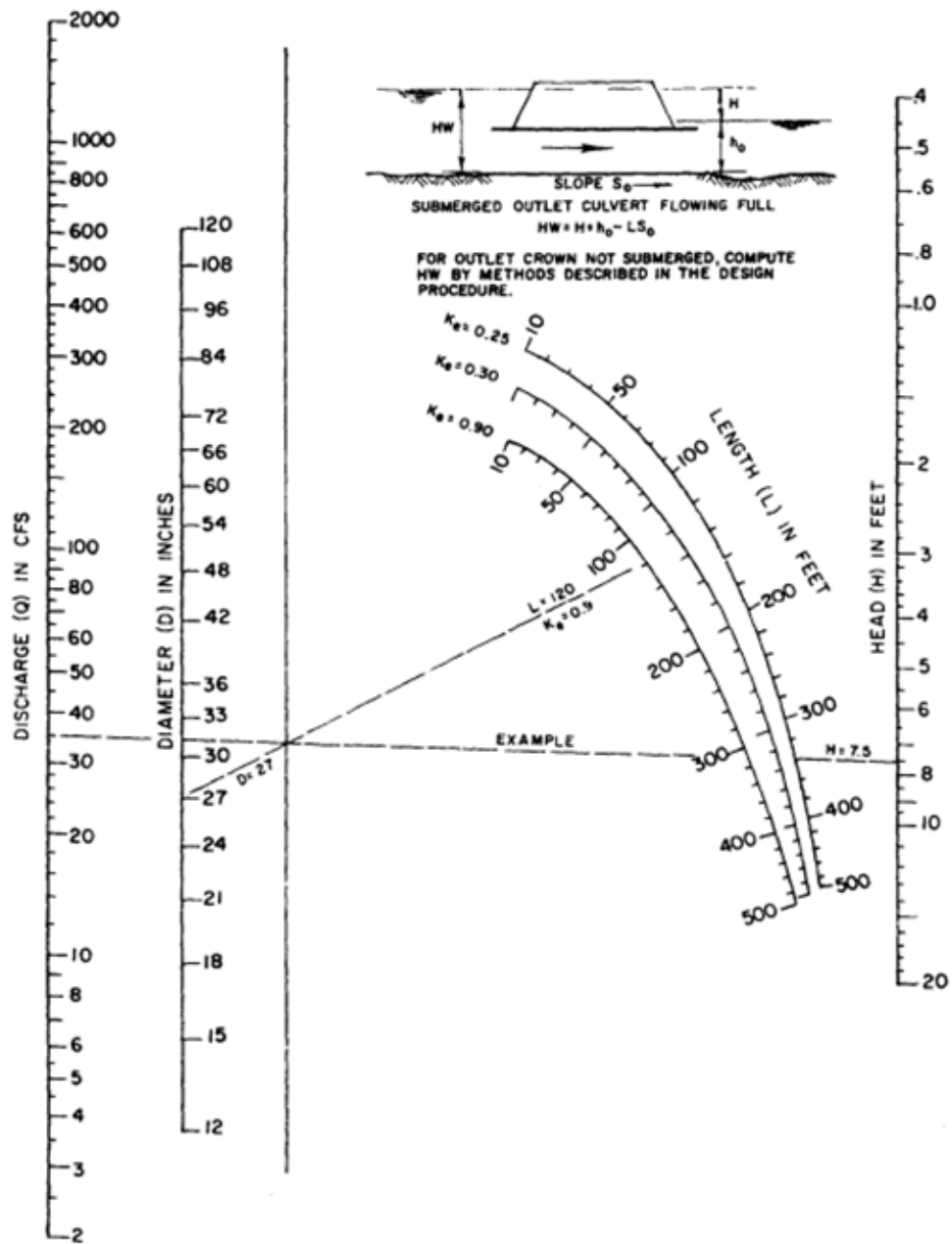

FOR OUTLET CROWN NOT SUBMERGED, COMPUTE HW BY METHODS DESCRIBED IN THE DESIGN PROCEDURE.

HEAD FOR CM PIPE CULVERTS FLOWING FULL WITH OUTLET CONTROL  
 $n = 0.024$  (REF. HYD. ENG. CIR. NO. 5, USBPR, 1965)

EXHIBIT 13-4

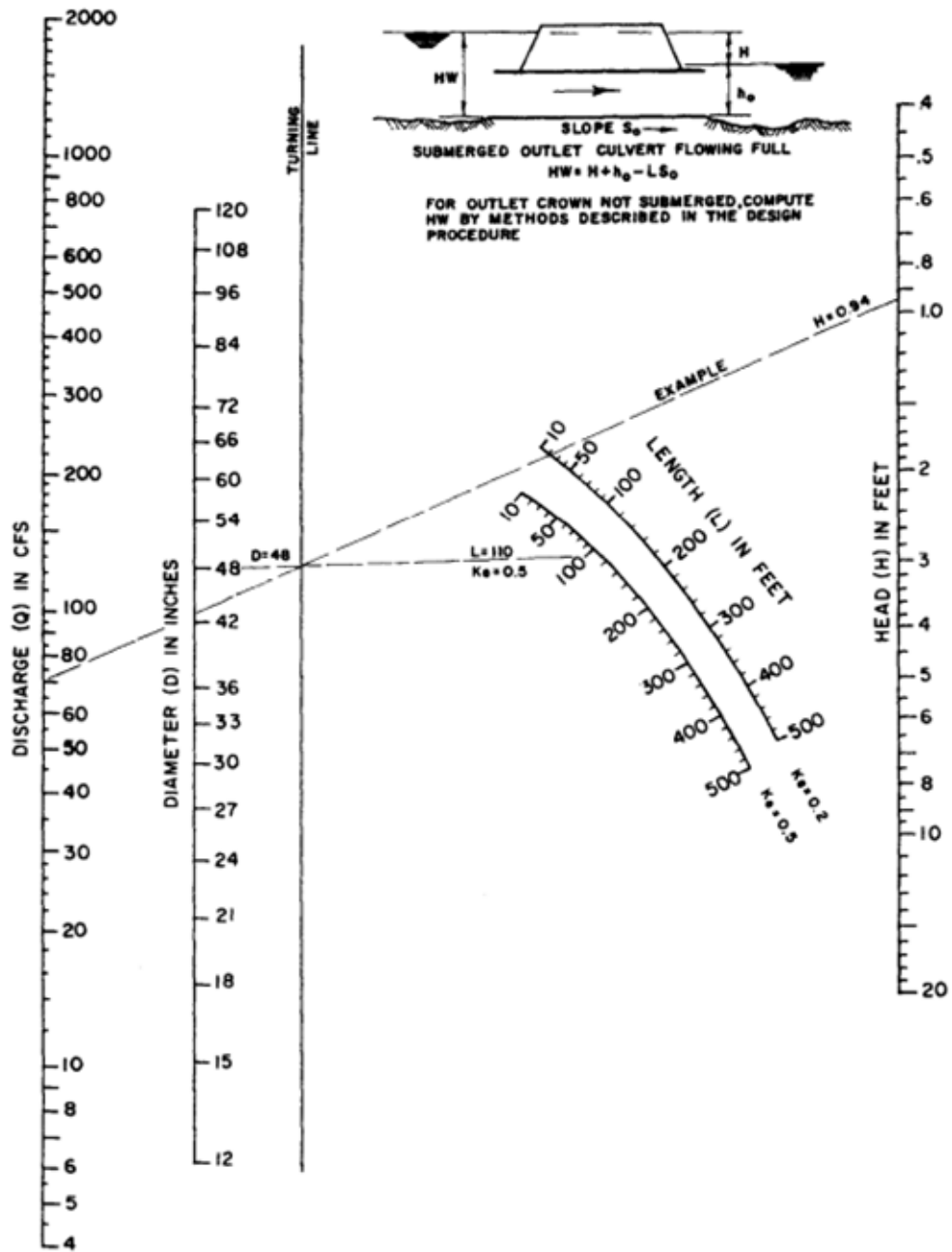

HEAD FOR CONCRETE PIPE CULVERTS FLOWING FULL WITH OUTLET CONTROL  
 $n = 0.012$  (REF. HYD. ENG. CIR. NO. 5, USBPR, 1965)

**EXHIBIT 13-5**

STRUCTURE PROPORTIONING COMPUTATION SHEET

CULVERT NO. \_\_\_\_\_

Q (Exhibit 2-7) = \_\_\_\_\_ cfs

Stream pH = \_\_\_\_\_

Type of Culvert = \_\_\_\_\_

INLET CONTROL

Type of inlet: \_\_\_\_\_ (headwall, projecting, mitered to conform to slope and so forth)

Diameter of Culvert (D) = \_\_\_\_\_ ft.

Headwater (HW) = \_\_\_\_\_ ft.

(HW/D) = \_\_\_\_\_

Q (Exhibit 13-1, 13-2) = \_\_\_\_\_ cfs

Culvert Slope (So) = \_\_\_\_\_ %

Type of discharge protection = \_\_\_\_\_

OUTLET CONTROL

Diameter of Culvert (D) = \_\_\_\_\_ ft.

Headwater (HW) = \_\_\_\_\_ ft.

Length (L) = \_\_\_\_\_ ft.

Culvert slope(s) \_\_\_\_\_ %

Mannings Number (N) \_\_\_\_\_

Concrete N = 0.012

CMP N = 0.024

Entrance Loss Coefficient (Table 13-1) (Ke) = \_\_\_\_\_

Free Water Surface ( $h_o = 3/4D$ ) = \_\_\_\_\_

HW = H +  $h_o$  - LS<sub>o</sub> = \_\_\_\_\_

Q (Exhibit 13-3, 13-4) = \_\_\_\_\_ cfs.

**Table 13-1**  
Entrance Loss Coefficients

Type of Structure and Design of Entrance	Coefficient $K_e$
<u>Pipe, Concrete</u>	
Projecting from fill, socket end (groove-end) -----	0.2
Projecting from fill, sq. cut end -----	0.5
Headwall or headwall and wingwalls	
Socket end of pipe (groove-end) -----	0.2
Square-end -----	0.5
Rounded (radius = 1/12D) -----	0.2
Mitered to conform to fill slope -----	0.7
*End-section conforming to fill slope -----	0.5
<u>Pipe, or Pipe-Arch, Corrugated Metal</u>	
Projecting from fill (no headwall) -----	0.9
Headwall or headwall and wingwalls	
Square-edge -----	0.5
Mitered to conform to fill slope -----	0.7
*End-section conforming to fill slope -----	0.5
<p>Note: *"End-section conforming to fill slope," made of either metal or concrete, are the sections commonly available from manufacturers. From limited hydraulic tests they are equivalent in operation to a headwall in both inlet and outlet control.</p>	

FIGURE 13-1

Type of Inlet Control

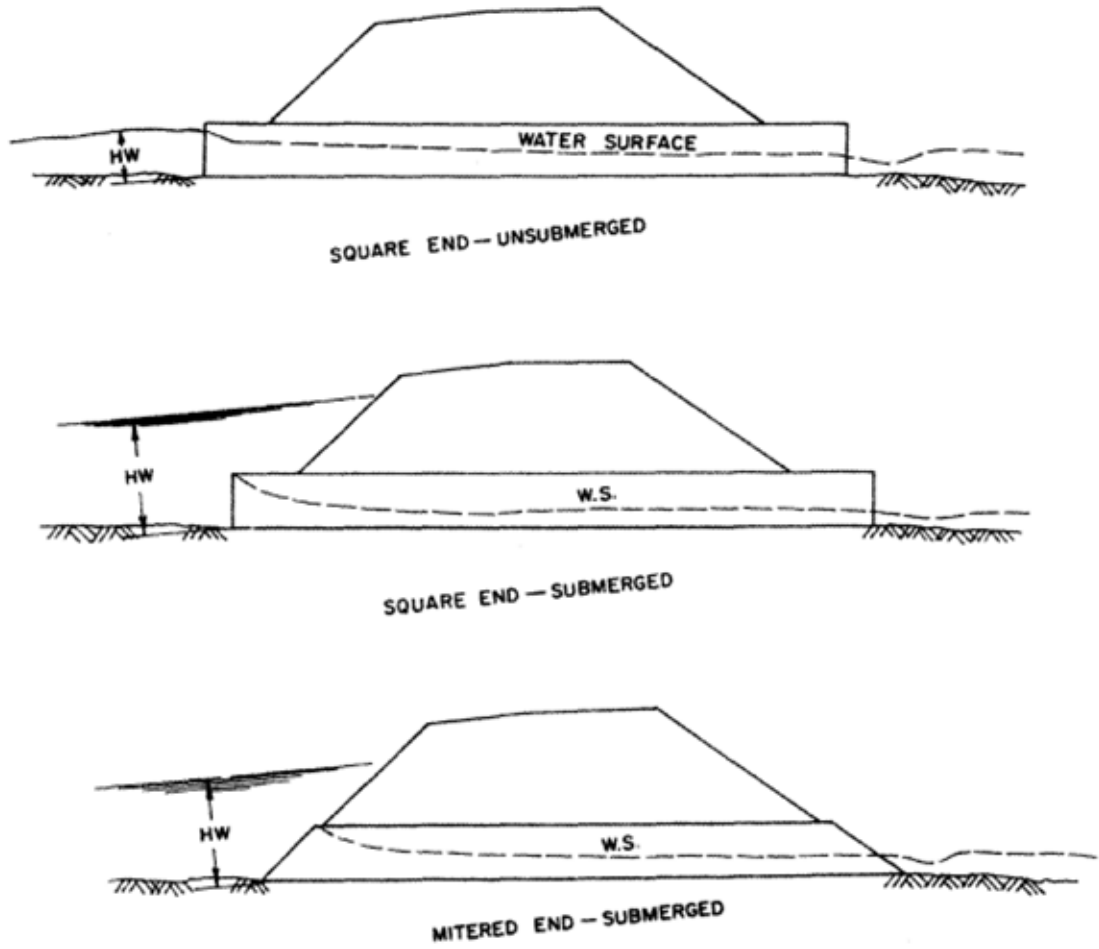
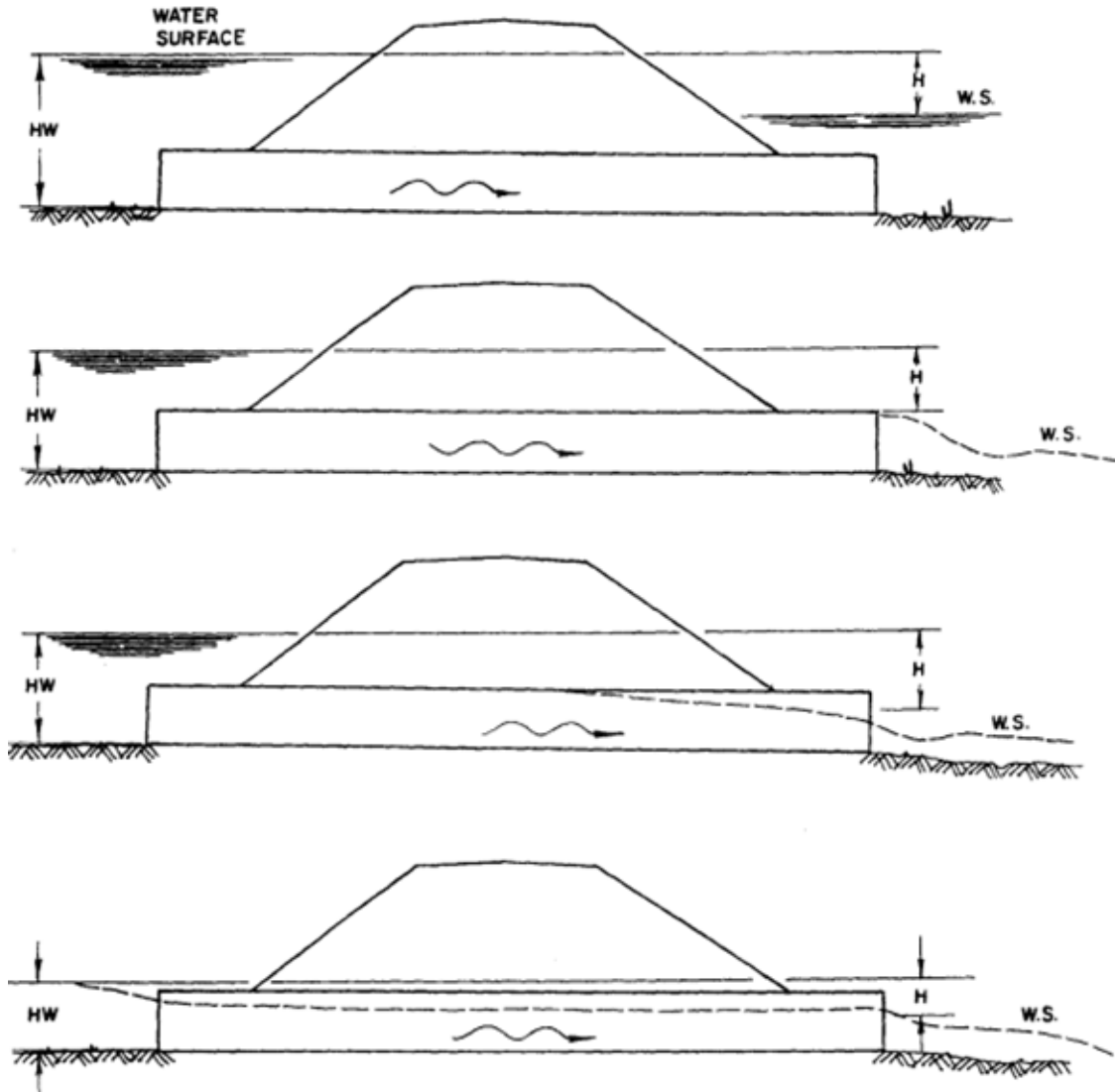

FIGURE 13-2

Type of Inlet Control



# *14 Bench Control Systems*

## *CONTENTS*

Definition	1
Purpose	1
Scope	1
Drainage Area and Site Evaluation and Limitations	1
Sediment	1
Water Quality Standards	2
Permanent Systems	2
	<i>Outlet Devises</i>
	<i>Open Exit Channel</i>
	<i>Pipe Spillway</i>
Temporary Drainage System	3
Plans, Design Data and Specifications	3

## BENCH CONTROL SYSTEMS

### 14.1 DEFINITION

A sediment control structure located on a solid bench at or near the backfill material (disturbed area) to form an erosion and sedimentation control system for steep slope mining, area mining, haulback mining and mountain top removal mining.

### 14.2 PURPOSE

To preserve the capacity of reservoirs, ditches, canals, diversions, waterways and streams and to prevent undesirable deposition on bottom lands, in channels or waterways and other areas by providing basins for the deposition and storage of silt, sand, gravel, stone and other sediment.

### 14.3 SCOPE

This chapter established the minimum acceptable quality for the design and construction of a bench control system in predominantly rural or agricultural areas in West Virginia when: failure of the systems would not result in loss of life; in damages to homes, commercial or industrial buildings; main highways or railroads; in interruption of the use of service of public utilities.

### 14.4 DRAINAGE AREA AND SITE EVALUATION AND LIMITATIONS

The contributing watershed above the site shall have an adequate plan for providing protection against erosion of disturbed areas in order to stabilize the area as quickly as possible after it has been disturbed. The plan is also to include utilization of one or many methods of "Water Management Practices" in Chapter 19 to assist the overall erosion and sedimentation control system. All areas disturbed during the mining operation in the watershed shall be revegetated according to West Virginia Division of Mining and Reclamation regulations and Chapter 20 of this handbook on revegetation.

### 14.5 SEDIMENT

The bench control system shall form a structure with a capacity to store 0.125 acre-foot per acre of disturbed area at normal pool elevation in the drainage area, the system may store only the runoff from a 10-year, 24-hour precipitation event as approved by the Director of the Department of Environmental Protection Mining and Reclamation. Consideration may be given for reduced storage volume where the pre-plan reflects the following:

- a. Controlled Placement
- b. Concurrent Reclamation Practices
- c. On-site Sediment Control Measures
- d. Access and Availability of all Structures

The disturbed area includes all land affected by previous operations that is not presently stabilized, all land that will be affected during the surface mining operations and all reclamation work, and may include all other lands which have been disturbed by timber operations, construction operations, other surface mining operations, etc.

The structure shall be cleaned out when the sediment accumulation approaches sixty percent (60%) of the design capacity. The design and construction drawings shall indicate the corresponding elevations.

## 14.6 WATER QUALITY STANDARDS

Discharges from bench control system, if classified as primary structures, which control areas disturbed by surface mining operations must meet all applicable Federal and State laws and regulations. The minimum effluent limitations shall be governed by the standards set forth in the NPDES Programs under the Federal Water Pollution Control Act as amended, 33 U.S.C. 1251 et. seq., and the rules and regulations promulgated thereunder.

## 14.7 PERMANENT SYSTEMS

The permanent bench control system incorporating ditch storage shall be built on an approximate level grade, minimum zero percent (0%) to a maximum of two percent (2%) to ensure that complete storage volume will be maintained and system shall be constructed on a solid bench.

The types of systems cross-sections view can be either triangular or trapezoidal with side slopes no steeper than 2 horizontal to 1 vertical constructed with earth and 1/4 horizontal to 1 vertical constructed with rock.

A barrier may be installed across the channel or ditches at intervals no more than 500 feet to assure meeting the above grade and storage requirements. Final outlet device shall carry at all times the flow considering failure of one or all barriers. Plans, design data and specifications for types of barriers are in Chapter 19, "Water Management Practices" such as Stone Check Dams in Section 19.2, Log and Pole Structures in Section 19.4 and Earthen Barriers as outlined in Chapter 15, "Excavated Sediment Channel".

### 14.7.1 OUTLET DEVICES

The outlet devices shall be installed at any intervals which will assure the following requirements: Storage volume, grade limitations, safety outlet protection of any other conditions that may be required. Outlet devices shall be constructed and operable and shall be kept current with the actual overburden removal area.

All outlet control devices may be required to bypass safely a 10-year, 24-hour precipitation event and/or meet or exceed the minimum standards for an open exit channel or pipe spillway. A minimum of 1 foot of freeboard will be required on all drainage outlet devices.

#### 14.7.1.1 OPEN EXIT CHANNEL

Open exit channels shall be thoroughly protected with a rock riprap blanket in accordance to standards and specifications for rock riprap as outlined in Chapter 19, "Water Management Practices". The minimum width shall be 5 feet, minimum side slopes of 2 horizontal to 1 vertical and shall also be protected with rock riprap for a vertical height of 2 feet.

#### 14.7.1.2 PIPE SPILLWAY

Pipe spillway shall be a minimum of 12 inches' diameter with or without a vertical riser attached and may be perforated in accordance to Chapter 19, "Water Management Practices" to allow for a gradual draw down of water in the system.

### 14.8 TEMPORARY DRAINAGE SYSTEM

The objective of the temporary drainage system is to provide sediment control measures on mining operations until the final permanent drainage system can be installed as designed and certified in the mining and reclamation plan.

The temporary drainage control system shall be installed and maintained at least 200 feet in advance of any disturbance of the mining operation. All temporary drainage systems shall be maintained until finalization of the permanent drainage system.

The temporary drainage system installation and maintenance shall be kept current with the drill bench disturbance and approved by the Director or his authorized agent of the Department of Environmental Protection Mining and Reclamation as being installed according to the approved mining and reclamation plan at least once every thirty (30) days or 500 feet, whichever comes first.

All areas of temporary drainage systems shall be indicated in the approved pre-plan as disturbed area and may be required to be seeded and mulched in accordance to the revegetation plan if systems will be utilized in excess of sixty days.

The systems shall prevent, to the extent possible, additional contribution of sediment to stream flow or to runoff outside the permit area, and all discharges from the disturbed area must meet the effluent limitations as set forth in Section 14.6.

Types of temporary drainage systems such as, but not limited to: toe berms, filter fences, outcrop roadways, temporary diversion ditched or other sediment traps, are outlined in Chapter 19, "Water Management Practices".

### 14.9 PLANS, DESIGN DATA AND SPECIFICATIONS

In addition to the "Proposed Drainage Plan", there will also be submitted the following items concerning bench control systems.

1. A "Structure Proportioning Computation Sheet" to be completed for each type of system proposed.
2. Construction plans showing:
  - a. Planview and profile view of the system.
  - b. Cross-section view through the system showing all pertinent information.
  - c. Cross-section of barrier and outlet devices.
  - d. Maintenance schedule and procedures for maintenance.
  - e. Construction specifications.
3. If applicable, temporary drainage control system construction plans showing:

- a. Planview and profile view of the system.
  - b. Cross-section through the system showing all pertinent information.
  - c. Maintenance schedule and procedures for maintenance.
  - d. Construction specifications.
4. Procedures and Timetable for Abandonment.

# *15* *Bench Control Systems*

## *C O N T E N T S*

Definition	1	
Purpose	1	
Scope	1	
Sediment	1	
Water Quality Standards	1	
Design Criteria	2	
Plans, Design Data and Specifications	2	
Construction Specifications	3	
	<i>Stake-Out</i>	3
	<i>Excavation</i>	3
	<i>Surface Runoff</i>	3
	<i>Vegetative Protection Against Erosion</i>	3

## BENCH CONTROL SYSTEMS

### 15.1 DEFINITION

A Channel excavated below the toe of the spoil to form a silt or sediment basin for control of sediment from the outslope.

### 15.2 PURPOSE

To preserve the capacity of reservoirs, ditches, canals, diversions, waterways and streams and to prevent undesirable deposition on bottom lands, in channels or waterways and other areas by providing basins for the deposition and storage of silt, sand, gravel, stone and other sediment.

### 15.3 SCOPE

This chapter established the minimum acceptable quality for the design and construction of an excavated sediment channel in predominantly rural or agricultural areas in West Virginia when:

1. Failure of the embankment for the channel would not result in loss of life; in damages to homes, commercial or industrial buildings; main highways or railroads; in interruption of the use of service of public utilities.
2. The slope of the original ground on which the channel is constructed does not exceed thirty percent (30%).

### 15.4 SEDIMENT

The excavated sediment channel shall form a basin with a capacity to store 0.125 acre-feet per acre of disturbed area formed by the outslope of the spoil bank. The outslope area shall be based upon the maximum expected length of spoil slope. An outline of the predicted outslope area shall be shown on the proposed drainage plan.

The sediment in the channel shall be cleaned out when accumulation approaches sixty percent (60%) of the design capacity. The construction drawings shall indicate the corresponding elevation.

### 15.5 WATER QUALITY STANDARDS

Discharges from an excavated sediment channel which controls areas disturbed by surface mining operations must meet all applicable Federal and State laws and regulations. The minimum effluent limitations shall be governed by the standards set forth in the NPDES Program under the Federal Water Pollution Control Act. As amended, 33 U.S.C. 466 et. Seq., and the rules and regulations promulgated thereunder.

## 15.6. DESIGN CRITERIA

The excavated sediment channel shall be built on a level grade around the hill or mountainside. Adequate space shall be provided between the toe of the spoil bank and the channel to assure that sluffage from the spoil slope will not fill the channel.

Precaution shall be taken to assure that there is no overburden or spoil spillage over the outslope into the channel.

The excavated sediment channel shall have a V-notch cross-sectional appearance. The vertical depth of the inside cut or highwall shall not exceed 5 feet, and the slope of the cut shall not exceed 2 horizontal to 1 vertical.

The bench formed by the channel shall be a minimum of 14 feet wide and on a slope of no flatter than 5 horizontal to 1 vertical or steeper than 2:1 towards the cut slope.

The channel fill slope shall be no greater than 2 horizontal to 1 vertical. All trees and waste material shall be removed from beneath or through the fill slope.

An earthen barrier shall be installed across the channel at 100 foot intervals or less to assure that failure of the embankment or fill portion of the channel would result in release of water or sediment from only a 200 foot segment of the channel at any one time. The top or crest width of the barrier shall be no steeper than 2 horizontal to 1 vertical.

Drainage from an area other than the spoil outslope shall not be allowed to enter the channel at any time.

An outlet device from the excavated sediment channel must be maintained at all times to handle a 10-year, 24-hour storm event and outlet to a natural drainage or a properly designed outlet. The minimum requirement for outlet devices can be located in Chapter 14, "Bench Control System", Section 14.7.1.

## 15.7 PLANS, DESIGN DATA AND SPECIFICATIONS

In addition to the "Proposed Drainage Plan", there will also be submitted the following items:

1. A "Structure Proportioning Computation Sheet" to be completed for each excavated sediment channel.
2. Construction plans showing:
  - a. Plan view drawn to scale of the channel and the outlet device.
  - b. Profile view drawn to scale of the channel with profile showing all pertinent data.
  - c. Cross-section view drawn to scale through the channel showing the maximum existing ground slope on which the channel is to be constructed and other information.
  - d. Cross-section of barrier as located in channel.

3. Construction specifications.
4. Maintenance schedule to include, but not limited to, the following:
  - a. Procedures for maintenance,
  - b. Method of disposal of sediment
  - c. Access to structure for maintenance.
5. Procedures and Timetable for Abandonment.

## **15.8 CONSTRUCTION SPECIFICATIONS**

### **15.8.1. STAKE-OUT**

Prior to beginning the excavation of the channel, alignment and grade controls shall be established every 100 feet along the channel. Care shall be taken to establish a level, zero percent (0%) grade.

### **15.8.2. EXCAVATION**

The channel shall be excavated as shown on the construction plans. A barrier with a 5 foot crest width shall be placed through the channel every 200 feet or less. The channel may be discontinued and restated above or below the point where discontinued to avoid rock formations. In no case shall the channel be planned or built on a slope which exceeds thirty percent (30%).

### **15.8.3. SURFACE RUNOFF**

Surface runoff from an area other than the spoil outslope shall not be allowed to enter the channel at any time.

### **15.8.4. VEGETATIVE PROTECTION AGAINST EROSION**

All disturbed areas created during the construction of the channel shall be seeded and mulched immediately after construction in accordance with Chapter 20 of this handbook for revegetation.

# *16 Clarification and Inspection*

## *CONTENTS*

Scope		1
Procedure for Certification		1
Variance of Certification Procedures		1
	<i>Certification of Bench Control System</i>	1
	<i>Certification of Valley Fill, Side Fill &amp; Rock Fill</i>	2
Procedures for Inspections		2
Variance of Inspection Report		2

## CERTIFICATION AND INSPECTION

### 16.1 SCOPE

All erosion and sedimentation control systems such as, but not limited to, Sediment Dams, Embankment Type; Excavated Sediment Dams, Excavated Sediment Ponds, Gabion Sediment Dams; Crib Sediment Dams; Haulageway and Access Roads (temporary and permanent), which have been submitted for technical review and approved shall be constructed and/or installed and certified prior to any disturbance in that sediment control structure component drainage area.

After completion of the required certifications, an inspection process shall be initiated by the operator.

### 16.2 PROCEDURE FOR CERTIFICATION

A certification form can be found on WVDEP's Electronic Submission System (eSS) and shall be submitted to the Department of Environmental Protection, Division of Mining and Reclamation, for each component drainage area system as it is completed and prior to any disturbance of operation in that component drainage area.

The certification form shall be hereby certified by a person approved by the Director of the Department of Environmental Protection Mining and Reclamation, except that Valley Fills, Side Hill Fills and Rock Fills shall be certified by a Registered Professional Engineer; that the erosion and sediment control system is (are) constructed and installed in accordance with the technical aspects of the approved pre-plan and any modifications thereto, as approved by the Department of Environmental Protection Mining and Reclamation.

Any minor changes which equal or exceed the approved system occurring during construction such as, but not limited to, increased width or emergency spillway or entrance channel, increased size of storage volume, increased top width of embankment, etc.; shall be indicated on "As-built" plans showing approved design, amount of minor change, and reference points and shall be submitted along with the Certification of Drainage Form (MR-13) to the department.

### 16.3 VARIANCE OF CERTIFICATION PROCEDURES

#### 16.3.1 CERTIFICATION OF BENCH CONTROL SYSTEM

If utilizing a bench control system, outlined in Chapter 14, as the primary sediment control structure for the operation, then the permanent system shall be certified as follows:

1. If the system is constructed totally prior to mining, then the system shall be certified prior to conducting mining operations.
2. If the system is constructed progressively with the mining operation, then the system shall be constructed and certified (Certification of Drainage Form MR-13) in sections

of 1,000 linear feet (maximum) measured from the active mineral removal area. This certification must include a map showing exact location of certified section.

### **16.3.2 CERTIFICATION OF VALLEY FILL, SIDE FILL & ROCK FILL**

In the utilization of an access spoil disposal area outlined in Chapters 8, 9, and 10, the above fills shall be certified upon completion of construction by a Registered Professional Engineer.

## **16.4 PROCEDURES FOR INSPECTIONS**

After completion and approval of the certification as required in the above sections, a quarterly inspection shall be initiated on all erosion and sedimentation control systems such as, but not limited to, Sediment Dams, Embankment Types; Excavated Sediment Dams; Gabion Sediment Dams; and Crib Sediment Dams. Each structure at a minimum shall be examined for structural weakness, erosion patterns and other hazardous conditions. An inspection report shall be submitted to the Division of Mining and Reclamation within two weeks after the inspection. The report shall be certified by a person approved by the Director of the Department of Environmental Protection.

## **16.5 VARIANCE OF INSPECTION REPORT**

An inspection report will not be required on erosion and sedimentation control systems such as, but not limited to, Haulageway and Access Roads; Diversions; and Temporary and Permanent Stream Diversions.

# *17 Abandonment Procedures for Sediment Control Structures*

## **CONTENTS**

Scope	1
Abandonment Procedures	1
<i>Excavated Sediment Pond, Dougout Type</i>	1
<i>Sediment Dams, Embankment Type and Excavated     Sediment Dam, Embankment Type</i>	1
<i>Crib or Gabion Sediment Control Structures</i>	1
<i>Bench Control Systems</i>	1
Revegetation of Disturbed Areas	2
Disposal of Waste Material	2
	2

## ABANDONMENT PROCEDURES FOR SEDIMENT CONTROL STRUCTURES

### 17.1 SCOPE

This chapter shall cover the minimum requirements for abandoning sediment control structures prior to total release of bond for the particular permit. These abandonment procedures may be waived if the structure or structures are to be immediately utilized under another permit or the special land use requirements of the rules and regulations are adhered to and approved by the Director of the Department of Environmental Protection Mining and Reclamation.

All abandonment procedures shall be completed before the total bond is released.

### 17.2 ABANDONMENT PROCEDURES

#### 17.2.1 EXCAVATED SEDIMENT POND, DUGOUT TYPE

There is no required abandonment procedure for excavated sediment ponds unless they have an embankment. If they have an embankment, they shall follow the abandonment procedures outlined in Section 17.2.2

#### 17.2.2 SEDIMENT DAMS, EMBANKMENT TYPE AND EXCAVATED SEDIMENT DAM, EMBANKMENT TYPE

Sediment dams and all accumulated sediment above the dam shall be removed from the natural drainway if they built across it. Dams adjacent to natural drainways shall be abandoned by diverting the entrance channel to the natural drainways; thus, preventing any future surface runoff from entering the impoundment.

When sediment dams are removed, the natural drainway shall be returned to its original profile and cross-section as near as practical.

An original profile and cross-section view for the channel shall be submitted with the drainage plan. The channel sides and bottom shall be rock riprap in accordance to the standard and specifications for rock riprap as outlined in Chapter 19, "Water Management Practices", Section 19.19. The riprap shall extend up to the top of the channel. The riprap requirement may be waived where the bottom and sides of the channel consist of bedrock.

#### 17.2.3 CRIB OR GABION SEDIMENT CONTROL STRUCTURES

Crib or gabion sediment control structures and all accumulated sediment above the structure shall be removed from the natural drainway for abandonment. The natural drainway shall be returned to its original profile and cross-section. An original profile and cross-section view of the channel shall be submitted with the drainage plan. The channel shall be rock riprap in accordance to the standard and specifications for rock riprap as outlined in Chapter 19, "Water Management Practices", Section 19.19. The riprap requirement may be waived where the channel bottom and sides consist of bedrock.

#### **17.2.4 BENCH CONTROL SYSTEMS**

There is no required abandonment procedure for bench control systems.

#### **17.3 REVEGETATION OF DISTURBED AREAS**

All areas disturbed during abandonment of a sediment control structure shall be seeded and mulched immediately in accordance with Reclamation Rules Chapter 20 of this Handbook for Revegetation.

#### **17.4 DISPOSAL OF WASTE MATERIAL**

Waste material shall be spread continuously over an area designated on the drainage plan in accordance with these specifications.

Provisions shall be made for the diversion or safe passage of surface water concentrating on the land side of the spoil bank.

The spoil shall be placed so as not to endanger the stability of the stream bank and shall not exceed 3 feet in height above the natural ground surface, except by special design. Special designs shall be submitted with the drainage plan. The finished surface shall slope away from the edge of the stream or drainway insofar as feasible.

Surfaces of spoil shall not be steeper than 2 horizontal to 1 vertical.

If the spoil is spread to the edge of the stream bank, the stream side slope of the spoil shall be shaped to join the side slope of the stream bank so loose spoil will not slide or erode into the channel.

# *18*      *Regraded Drainage Control*

## *CONTENTS*

Definition		1
Purpose		1
Scope		1
Methods of Regraded Drainage Control		1
	<i>Continuous Flow Areas</i>	1
	<i>Constructed Drainage Facility</i>	1
	<i>Regraded Ditches</i>	2
General		2

## REGRADED DRAINAGE CONTROL

### 18.1 DEFINITION

A regraded drainage control system is one which assists in maintaining stability, aides in the retention of soil moisture, controls erosion and enhances establishment of vegetation.

### 18.2 PURPOSE

The purpose of regrading drainage control systems includes one or more of the following:

1. To preserve the capacity of reservoirs, ditches, canals, diversions, waterways and to prevent undesirable deposition of bottom land, in channels, streams or waterways.
2. Prevents rill and gully development.
3. Intercepts and conducts surface runoff at a non-erosive velocity to a stable outlet.
4. Reduces sediment content in water.

### 18.3 SCOPE

This chapter establishes the minimum acceptable quality for the design and construction of these systems located in predominantly rural or agricultural areas in West Virginia.

### 18.4 METHODS OF REGRADED DRAINAGE CONTROL

In completing a pre-plan for a mining operation, there shall be included a detailed regraded drainage control plan incorporating different systems necessary to maintain stability, decrease velocities, retain soil moisture and prevent additional contributions of sedimentation to the stream flow. The pre-plan shall indicate when, how and where the system will be constructed.

#### 18.4.1 CONTINUOUS FLOW AREAS

In areas of probable flows of water such as springs, natural seeps, natural drainways or constructed waterways, a channel must be designed and constructed in accordance to Chapter 11, "DIVERSION".

#### 18.4.2 CONSTRUCTED DRAINAGE FACILITY

In the case of haulback mining in steep slopes and contour mining, the constructed drainage facility must intercept and convey runoff without erosion of a backfill area and direct all upland flow to proper design outlet devices such as rock riprap, flumes, diversions, channels, french drains, culverts, level spreaders and etc.

A constructed drainage facility may be established near the top of the backfilled highwall. The drainage facility shall be utilized only, and shall be no larger than necessary, to prevent erosion of a backfill area. The drainage facility shall:

1. Eliminate the highwall remaining as a result of construction of (the mining operations) the drainage facility by backfilling or shaving, which means a reduction of a vertical cut of soft or unconsolidated material (shale, soil), in a manner which blends into the natural ground and compliments existing drainage patterns. No vertical rise of the highwall shall be retained except for occasional short segments in hard or consolidated rock with cannot be reduced mechanically.
2. Be rock riprap, vegetated or otherwise protected as approved by the Director to prevent excessive erosion;
3. Maintain a positive gradient so as to eliminate any potential impounding of water in the ditch; and
4. Not discharge over the outslope of the backfill in areas other than those protected by erosion and sedimentation control.

#### 18.4.3 REGRADED DITCHES

A regraded ditch is constructed on the final backfilling slopes as to direct all surface runoff to proper design outlet devices for the prevention of rills and gullies and to enhance the establishment of vegetation. Regraded ditches shall be designed and submitted in accordance with Chapter 11, "diversion", except for the following: Submittal of survey profile and pertinent information.

Ditches shall have the capacity to handle a 1-year, 24-hour precipitation event instead of a 10-year, 24-hour precipitation event.

Side slopes of ditches will be no steeper than 2 horizontal to 1 vertical and no flatter than 4 horizontal to 1 vertical.

### 18.5 GENERAL

The pre-plan, being as practical as possible, shall include all plans, design data and specifications as indicated in the above section for the anticipated regraded drainage control plan. The information required shall include a detailed set of construction specifications and also a detailed maintenance schedule.

# 19 Water Management Practices

## CONTENTS

Determining or Altering Sediment Basin Shape		1
	<i>Definition</i>	1
	<i>Purpose</i>	1
	<i>Condition where Practice Applies</i>	1
	<i>Design Criteria</i>	1
Stone Check Dams		2
	<i>Definition</i>	2
	<i>Purpose</i>	2
	<i>Conditions Where Practice Applies</i>	2
	<i>Design Criteria</i>	2
	<i>Maintenance</i>	3
Straw Bale Dike		5
	<i>Definition</i>	5
	<i>Purpose</i>	5
	<i>Conditions Where Practice Applies</i>	5
	<i>Design Criteria</i>	5
	<i>Construction Specifications</i>	5
Log and Pole Structures		6
	<i>Definition</i>	6
	<i>Purpose</i>	6
	<i>Conditions Where Practice Applies</i>	6
	<i>Design Criteria</i>	6
Filter Fence		8
	<i>Definition</i>	8
	<i>Purpose</i>	8
	<i>Conditions where Practice Applies</i>	8

	<i>Design Criteria</i>	8
	<i>Materials</i>	8
	<i>Construction Specifications</i>	9
Sediment Trap		12
	<i>Definition</i>	12
	<i>Purpose</i>	12
	<i>Conditions Where Practice Applies</i>	12
	<i>Design Criteria</i>	12
	<i>Construction Specifications</i>	12
Toe Berm		13
	<i>Definition</i>	13
	<i>Purpose</i>	13
	<i>Conditions Where Practice Applies</i>	13
	<i>Design Criteria</i>	13
Level Spreader		15
	<i>Definition</i>	15
	<i>Purpose</i>	15
	<i>Conditions Where Practice Applies</i>	15
	<i>Design Criteria</i>	15
	<i>Outlets</i>	15
Skimmer Device		17
	<i>Definition</i>	17
	<i>Purpose</i>	17
	<i>Conditions Where Practice Applies</i>	17
	<i>Design Criteria</i>	17
Perforation		17
	<i>Definition</i>	17
	<i>Purpose</i>	18
	<i>Conditions where Practice Applies</i>	18
	<i>Design Criteria</i>	18
Rock Riprap		18
	<i>Definition</i>	18
	<i>Purpose</i>	18
	<i>Conditions where Practice Applies</i>	18
	<i>Design Criteria</i>	18
Pumped Water Management		19
	<i>Definition</i>	19
	<i>Purpose</i>	19
	<i>Design Criteria</i>	19
Excelsior Blanket		19
	<i>Definition</i>	19
	<i>Purpose</i>	19
	<i>Conditions where Practice Applies</i>	20
	<i>Design Criteria</i>	20
	<i>Description</i>	20
Mulch Blankets		20
	<i>Definition</i>	20
	<i>Purpose</i>	20
	<i>Conditions Where Practice Applies</i>	20
	<i>Design Criteria</i>	20

Jute Netting		21
	<i>Definition</i>	21
	<i>Purpose</i>	21
	<i>Design Criteria</i>	21
	<i>Description</i>	22
Netting		22
	<i>Definition</i>	22
	<i>Purpose</i>	22
	<i>Conditions Where Practice Applies</i>	22
	<i>Design Criteria</i>	22
	<i>Description</i>	22
Rock Riprap Flume		23
	<i>Definition</i>	23
	<i>Purpose</i>	23
	<i>Conditions where Practices Applies</i>	23
	<i>Design Criteria</i>	23
	<i>Capacity</i>	23
	<i>Slope</i>	23
	<i>Rock Riprap</i>	23
	<i>Design</i>	23
French Drains		25
	<i>Definition</i>	25
	<i>Purpose</i>	25
	<i>Conditions Where Practice Applies</i>	25
	<i>Design</i>	25
Design Requirements for Rock Riprap		27
	<i>Definition</i>	27
	<i>Purpose</i>	27
	<i>Conditions Where Practice Applies</i>	27
	<i>Specifications</i>	27
	<i>Design, If Applicable</i>	27
	<i>Riprap</i>	28
	<i>Filter</i>	28
	<i>Soil Size Classification</i>	29
	<i>Quality</i>	29
	<i>Design Procedures</i>	29
	<i>Trapezoidal Channels</i>	30
	<i>Triangular Channels</i>	30
	<i>Construction</i>	31
	<i>Specifications</i>	31

## WATER MANAGEMENT PRACTICES

### 19.1 DETERMINING OR ALTERING SEDIMENT BASIN SHAPE

#### 19.1.1 DEFINITION

Method to increase the effectiveness of the sediment basin by minimizing the "short circuiting" sediment laden inflow to the outlet device.

#### 19.1.2 PURPOSE

The purpose is to increase the effective flow length from the inflow to the outflow. The normal pool area (storage elevation) shall have a length to width ration of at least 2.0 to 1.

#### 19.1.3 CONDITION WHERE PRACTICE APPLIES

Altering sediment basin shape shall be utilized in the sediment control structure plans so as to assist in meeting the water quality standards as outlined in the Technical Handbook by increasing detention time and decreasing velocity of inflow.

#### 19.1.4 DESIGN CRITERIA

The following procedure is used to determine shape of the basin. The length of this flow path (L) is the distance from the point of inflow to the outflow point. The pool area (A) is the area of the normal pool, sediment storage elevation. The effective width W(e) is found by this equation:

$$W(e) = A/L$$

$$L:W \text{ Ratio} = L/W(e)$$

In the event there is more than one inflow point, any inflow point which conveys more than thirty percent (30%) of the total peak inflow rate shall meet the length width (L:W) ratio criteria.

The required basin shape may be obtained by proper site selection, by excavation or by constructing a baffle in the basin.

The purpose of the baffle is to increase the effective flow length path. The baffle location and length will be such that a minimum 2:1 length width ration is obtained. The effective length L(e) shall be the shortest distance the water must flow from the inflow point to the outflow point. The equation shall be:

$$W(e) = A/L(e)$$

$$L:W \text{ Ratio} = L(e)/W(e)$$

## 19.2 STONE CHECK DAMS

### 19.2.1 DEFINITION

A barrier composed of large stone constructed across a drainway.

### 19.2.2 PURPOSE

To retard stream flow and form a small sediment basin in order to assist in sediment control.

### 19.2.3 CONDITIONS WHERE PRACTICE APPLIES

Stone check dams may be used only to assist in sediment control. They ARE NOT SUBSTITUTES for sediment dams or excavated sediment ponds. If used above such structures, stone check dams will in no way reduce the required sediment capacity (0.125 acre-feet/acre of disturbed area) of sediment control structures.

Stone check dams will not be used when the drainage area above them exceeds 50 acres. They may be used in locations such as:

1. In natural or constructed drainways close to the disturbed area in order to catch initial sediment loads.
2. In channels carrying water off the bench toward a natural drainway.
3. Other locations where small localized sedimentation problems exist.

### 19.2.4 DESIGN CRITERIA

A design is not required for stone check dams; however, the following standard criteria will be used:

1. Twenty-five percent (25%) of the rock will be 18 inches or larger. The remaining seventy-five percent (75%) shall be well graded material consisting of sufficient rock small enough to fill voids between the larger rocks.
2. The dam will be keyed into the sides and bottom of the channel a minimum depth of 3 feet. Minimum width of the key will be 3 feet.
3. Upstream slope and downstream slope will be 3 horizontal to 1 vertical.
4. A weir the average width of the stream channel and a minimum of 1 foot deep will be positioned at the center of the dam.
5. Maximum height will be 4 feet (from lowest point along centerline of dam to crest of weir).
6. Minimum top width shall be 5 feet.

### 19.2.5 MAINTENANCE

Stone check dams shall be cleaned when sediment capacity is approached.

#### EXAMPLE OF DETERMINING OR ALTERING SEDIMENT BASIN SHAPE

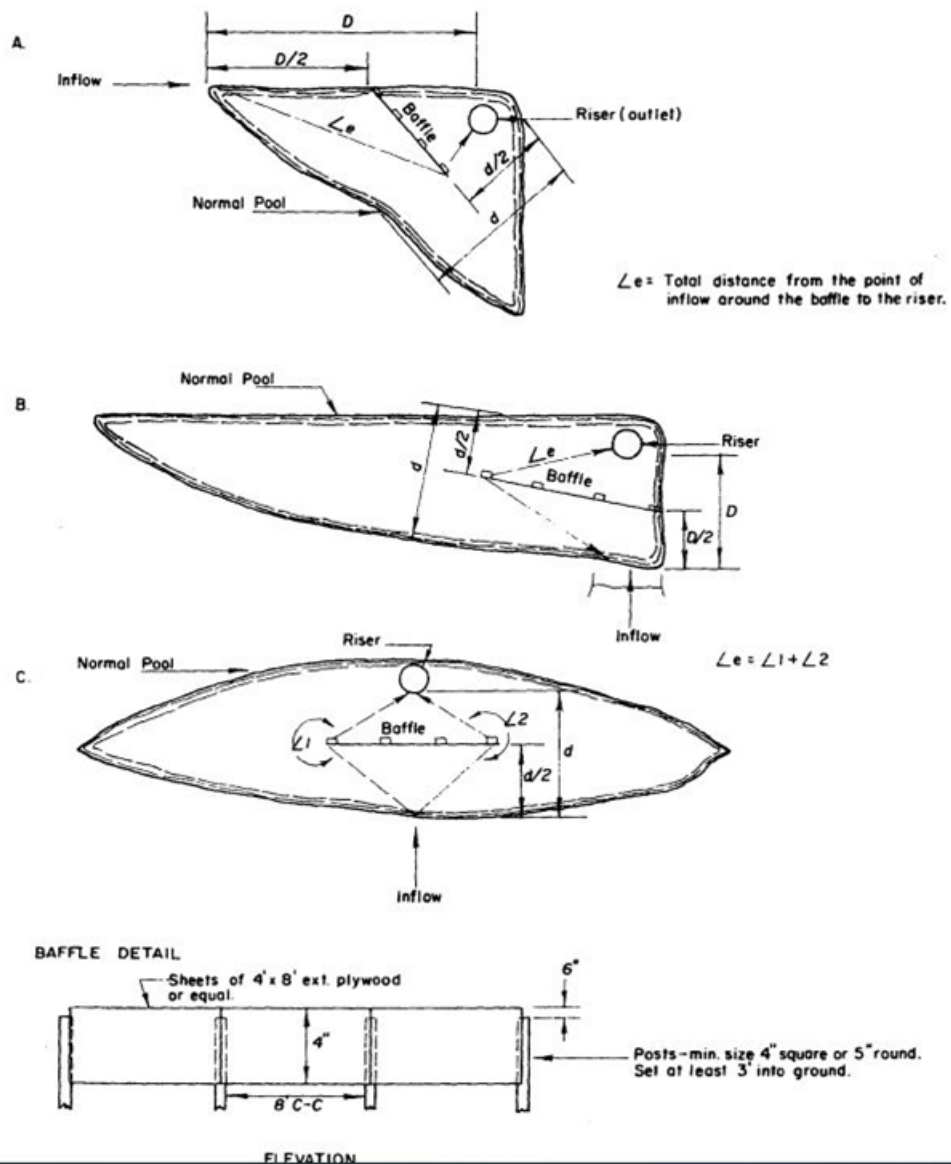

### STONE CHECK DAM

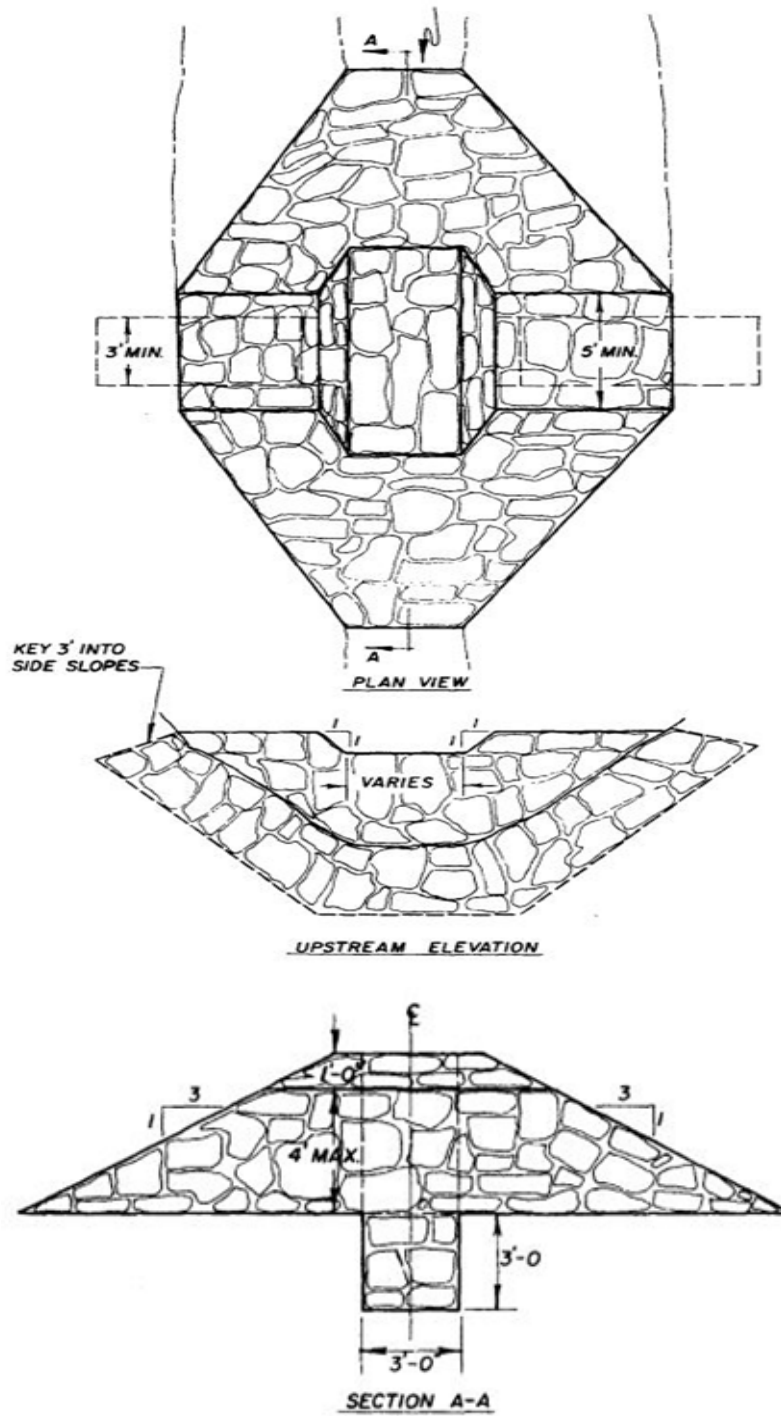

## 19.3 STRAW BALE DIKE

### 19.3.1 DEFINITION

A temporary barrier or structure with a life expectancy of three months or less, installed across or at the toe of a slope of the disturbed area.

### 19.3.2 PURPOSE

To intercept and detain small amounts of sediment from unprotected disturbed areas and to assist the overall sediment control plan.

### 19.3.3 CONDITIONS WHERE PRACTICE APPLIES

Dikes may be used only to assist in sediment control. They ARE NOT SUBSTITUTES for sediment control structures. Dikes will in no way reduce the required sediment capacity of sediment control structures.

The temporary straw bale dike may be used when:

1. There is no concentration of water in a channel or other drainageway above the dike.
2. Erosion would occur in the form of sheet and rill erosion.
3. The length of slope in the contributing drainage area above the dike is less than 200 feet. The slope should be fifteen percent (15%) or less. If the slope is greater than fifteen percent (15%), bales should be located on 100-foot spacing.

### 19.3.4 DESIGN CRITERIA

All bales shall be placed on the contour and should be tied with either wire or nylon string, if available.

### 19.3.5 CONSTRUCTION SPECIFICATIONS

1. Bales shall be placed in a row with ends tightly abutting the adjacent bales.
2. If bales are so constructed (curved ends) that a tight fit cannot be attained, the bales shall be embedded in the soil a minimum of 4 inches or bales covered with a fiber mat.
3. Bales shall be securely anchored in place by stakes or rebars driven through the bales. The first stake in each bale shall be driven toward previously laid bale to force bales together.
4. Inspection shall be frequent, and repair or replacement shall be made promptly as needed.
5. Bales shall be removed when they have served their usefulness.
6. Maintenance will be required on all structures to insure proper function of this intended purpose.

## 19.4 LOG AND POLE STRUCTURES

### 19.4.1 DEFINITION

A barrier composed of logs and poles constructed across a natural or constructed drainway.

### 19.4.2 PURPOSE

To retard stream flow and catch small sediment loads.

### 19.4.3 CONDITIONS WHERE PRACTICE APPLIES

Log and pole structures are to be used only to assist in sediment control and ARE NOT SUBSTITUTES for sediment control structures. When used, log and pole structures will not reduce the required sediment capacity (0.125 acre feet/acre of disturbed area of sediment control structures).

They may be used in locations such as:

1. In natural drainway close to the disturbed area to catch initial sediment loads.
2. In channel carrying water off the bench toward a natural drainway.
3. Other locations where small localized sedimentation problems exist.

### 19.4.4 DESIGN CRITERIA

A design is not needed for log and pole structures. Generally, they will follow the standard as shown on the illustration. Log and pole structures will not be used on drainway whose normal discharge is greater than 5 cubic feet per second.

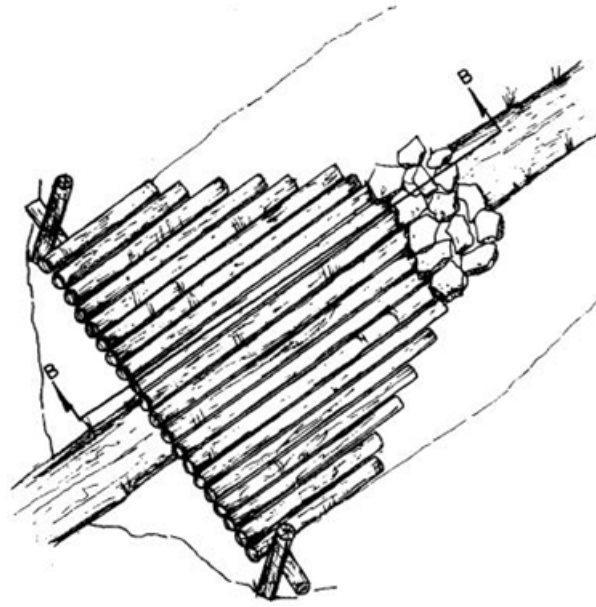

**LOG & POLE SILT STRUCTURE**

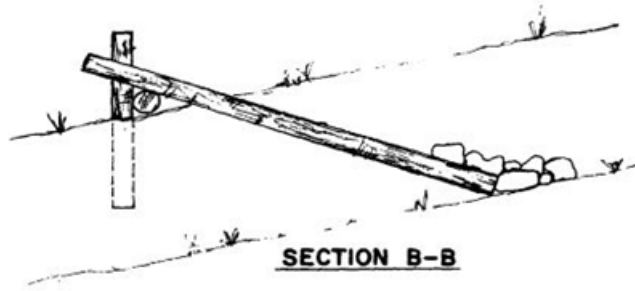

**SECTION B-B**

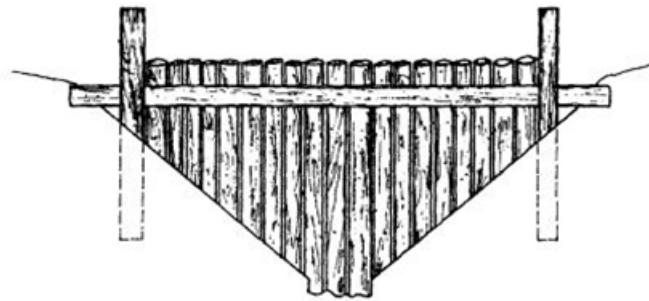

**UPSTREAM VIEW**

## 19.5 FILTER FENCE

### 19.5.1 DEFINITION

A temporary structure with a life expectancy of six (6) months or less. Installation shall be below a small disturbed area or at the toe of a slope.

### 19.5.2 PURPOSE

To intercept and detain sediment from small unprotected disturbed areas and to assist the overall sediment control plan.

### 19.5.3 CONDITIONS WHERE PRACTICE APPLIES

Filter fences may be used only to assist in sediment control. They ARE NOT SUBSTITUTES for sediment control structures. If used above such structures, fences will in no way reduce the required sediment capacity of sediment control structures. Filter fences will not be used when the drainage area above then exceeds 50 acres. They may be used in locations such as:

1. Areas of no concentration of water in a channel or other drainage way above the fence.
2. Areas where erosion will occur in the form of sheet and rill erosion.
3. If disturbed slopes are greater than twenty five percent (25%), fence should be located on 100 foot spacings. If slopes are less than twenty five percent (25%), fence will be located on 200 foot spacings.

### 19.5.4 DESIGN CRITERIA

Design computations are not required. All filter fences shall be placed as close to the contour as possible. A detail of the filter fence shall be shown, on the plan, and contain the following minimum requirements:

1. The type, size and spacing of fence posts.
2. The size of woven wire support fence.
3. The type of filter cloth used.
4. The method of anchoring the filter cloth.

### 19.5.5 MATERIALS

1. Filter Fence Cloth: Filter X, Polyfilter X, Mirafi 100X, Erosion Control Cloth, Bidim, or approved equal, which is resistant to the sun's rays.

2. Fence Posts: The length shall be a minimum of 48 inches long. Wood posts will be of sound quality hardwood with a minimum diameter of 2 inches or as approve. Steel posts will be standard T or U section weighing not less than 1.33 pounds per linear foot.
3. Wire Fence: Woven wire fencing shall be a minimum 14-1/2 gage with a maximum 6 inch mesh opening, or as approved.

### **19.5.6 CONSTRUCTION SPECIFICATIONS**

1. The fence posts shall be spaced a maximum distance of 10 feet center-to-center.
2. Woven wire fence shall be fastened securely to the upstream side of the fence posts by staples or wire ties.
3. Staple or fasten securely the filter cloth to the upstream side of the woven wire, allow sufficient filter cloth for anchor at the bottom.
4. The filter cloth shall be embedded in the soil a minimum of 4 inches and have compact soil to hold it in place.
5. The inspection shall be frequent, and the filter cloth shall be replaced promptly as needed if it is torn.
6. Maintenance will be required on all structures to ensure proper function of the intended purpose.

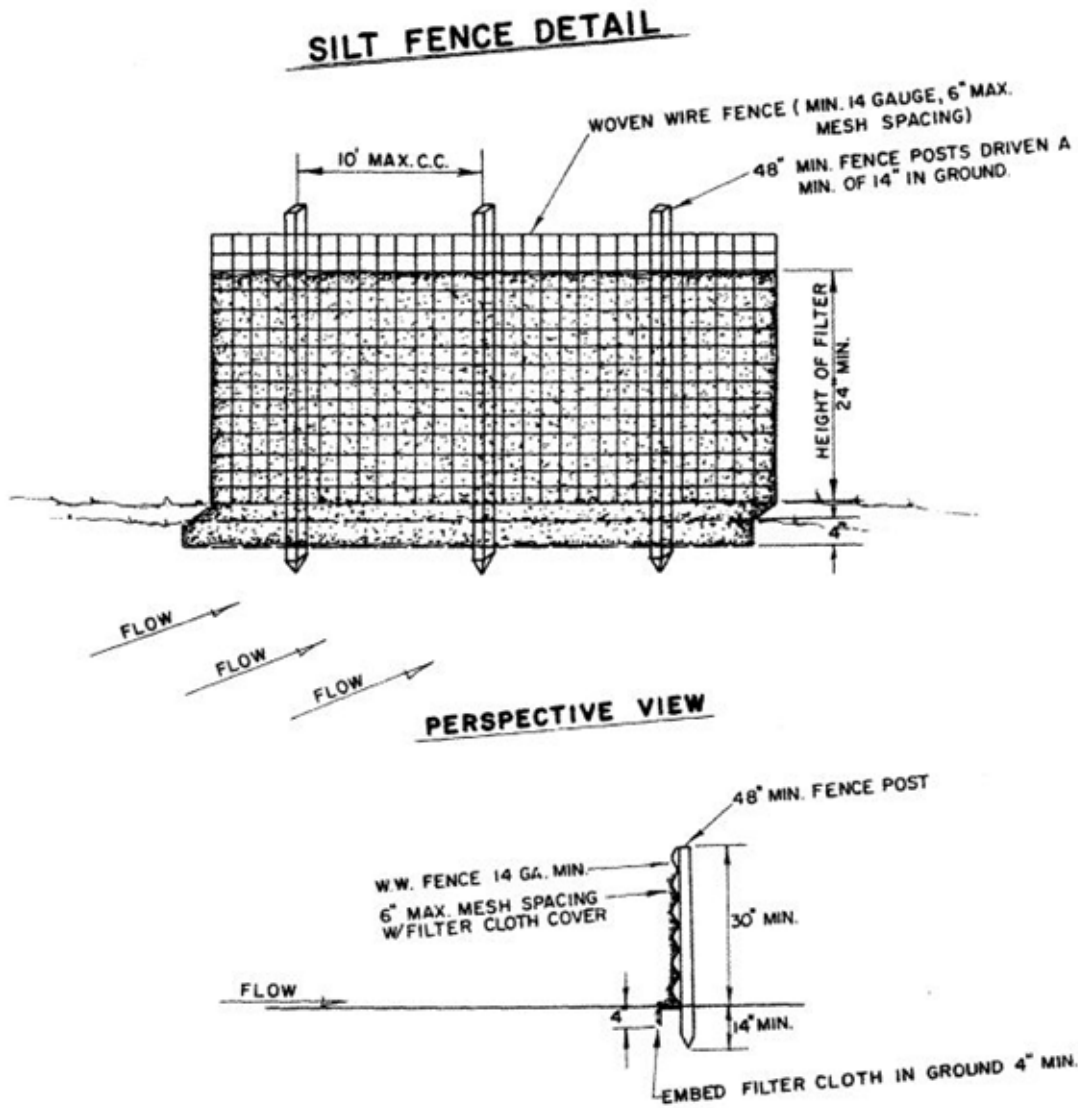

**SECTION**

**CONSTRUCTION NOTES**

- |  |   |
|--|---|
| <ol style="list-style-type: none"> <li>1. Woven Wire Fence to be Fastened Securely to Fence Posts With Wire Ties or Staples.</li> <li>2. Filter Cloth to be Fastened Securely to Woven Wire Fence With Wire Ties Spaced Every 24" at Top and Mid-Section.</li> <li>3. See Step by Step Procedure on Next Sheet.</li> </ol> | <p>Posts: Steel Either T or U Type or 2" Hardwood</p> <p>Fence: Woven Wire, 14 GA, Max 6" Mesh Opening</p> <p>Filter Cloth: Filter X Mirifi 100X, Laurel Erosion Control Cloth Bidim or Equal Polyfilter X.</p> |
|--|---|

### BUILDING A SILT FENCE A STEP BY STEP PROCEDURE

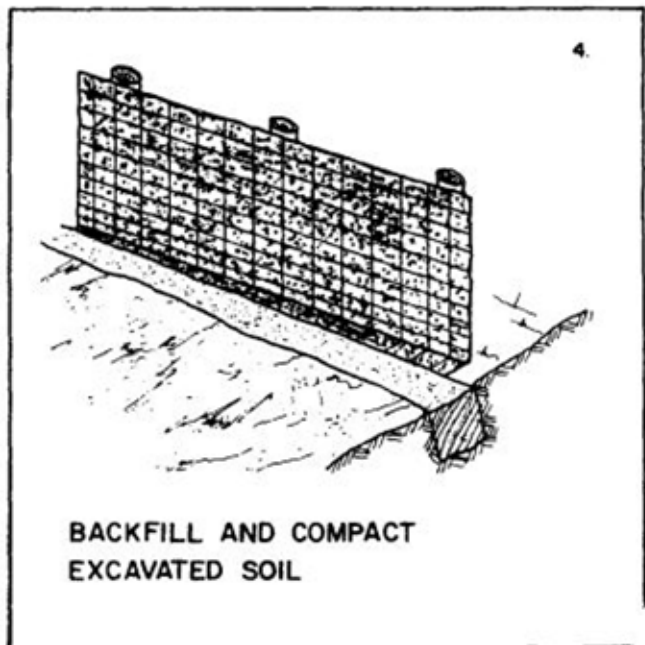
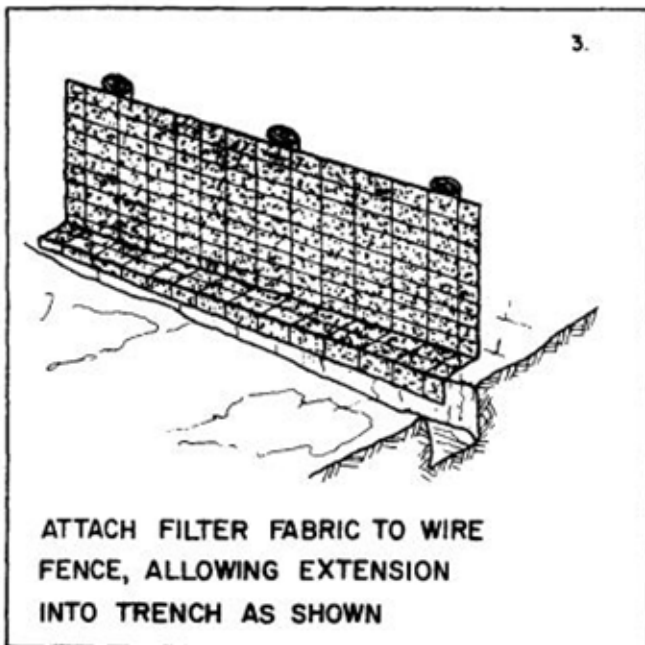
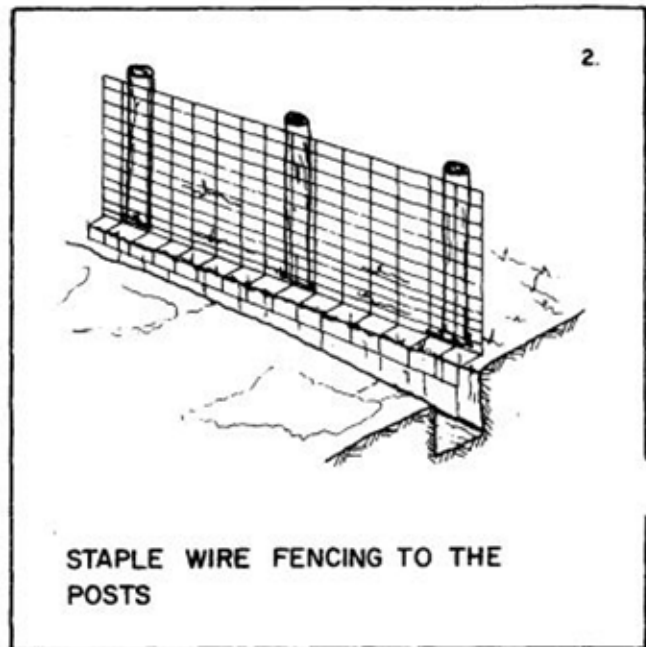
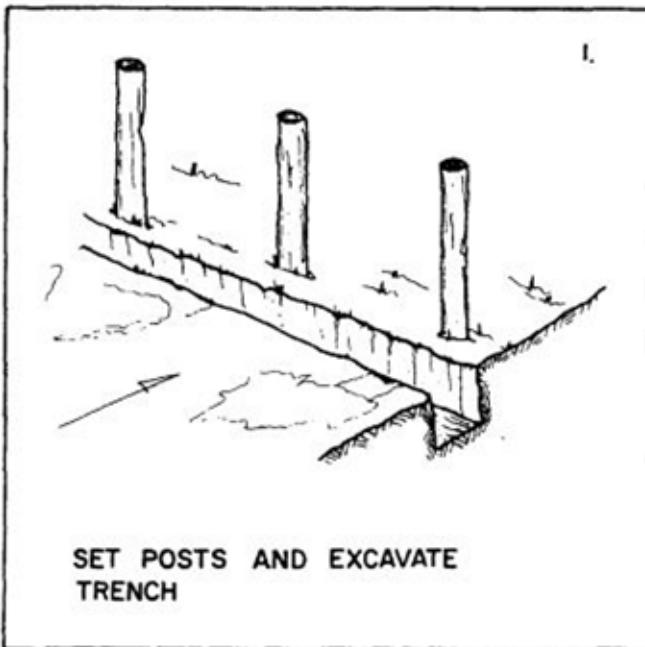

## 19.6 SEDIMENT TRAP

### 19.6.1 DEFINITION

A small temporary basin formed by excavation to intercept sediment laden runoff and to trap and retain the sediment.

### 19.6.2 PURPOSE

The purpose of a sediment trap is to intercept sediment laden runoff and trap the sediment in order to protect drainageways, ditches and streams below the sediment trap from sedimentation.

### 19.6.3 CONDITIONS WHERE PRACTICE APPLIES

A sediment trap is usually installed in a drainageway at a culvert inlet or at other points of discharge from a disturbed area. Sediment traps may be used only to assist in sediment control structures for mining operation areas. They ARE NOT SUBSTITUTES for sediment control structures for mining operation areas. Traps will in no way reduce the required sediment capacity of sediment control for haulageways, access roads and temporary bench control systems.

### 19.6.4 DESIGN CRITERIA

The trap should be located to obtain the maximum storage benefit from the terrain for ease of cleanout and disposal of the trapped sediment and to minimize interference with activities proposed. The sediment trap size shall have a minimum capacity of 80 cubic feet per acre of disturbance within the drainage area. The sediment shall be cleaned out when it reaches forty percent (40%) of the design sediment requirement.

All excavation for construction of traps shall be carried out in such a manner that erosion and water pollution shall be minimal. Any excavation portion of traps shall have a 2 horizontal to 1 vertical in earth and 1/4 horizontal to 1 vertical in rock.

An adequate outlet shall be maintained for all sediment traps, such as, but not limited to: Culvert, vertical riser, rock riprap and open channels.

### 19.6.5 CONSTRUCTION SPECIFICATIONS

Construction operations shall be carried out in such a manner that erosion and water pollution are minimized. Also, the structure shall be inspected after each rain and repairs made immediately.

## 19.7 TOE BERM

### 19.7.1 DEFINITION

A berm or "bench" of compacted and vegetated soil constructed to act as a temporary sediment control system for bench control systems, haulageway construction, sediment structure construction and etc.

### 19.7.2 PURPOSE

To control sheet and gully erosion from the disturbed areas by diminishing the velocity of the runoff and making it possible for sediment to deposit.

### 19.7.3 CONDITIONS WHERE PRACTICE APPLIES

The toe berm can be used at the toe of the outer spoil slope to control excessive erosion until the slope has been properly revegetated the stabilized. The toe berm should be constructed as soon as spoil slope is established. This shall be done as mining progresses. The berm shall not be built where concentrated flows from the bench area or other areas occur; it shall be built only where runoff is from spoil slope. A temporary control system can be used for bench control systems and for temporary sediment control during construction of haulageways, sediment structures etc.

### 19.7.4 DESIGN CRITERIA

A design is not required for toe berms; however, the following standard criteria will be used:

1. Toe berm will be sloped a minimum of one percent (1%) and a maximum of three percent (3%) away from the toe of spoil, inside slope or other conditions.
2. Outer slope of the toe berm will be 2 horizontal to 1 vertical or flatter.
3. Toe berm will be seeded and mulched immediately after construction and shall cover the outer slope of the berm and shall extend a minimum of 10 feet up the spoil slope. The pH and nutrient level of the soil shall be such that a vigorous stand of vegetation can be established.

# TOE BERM

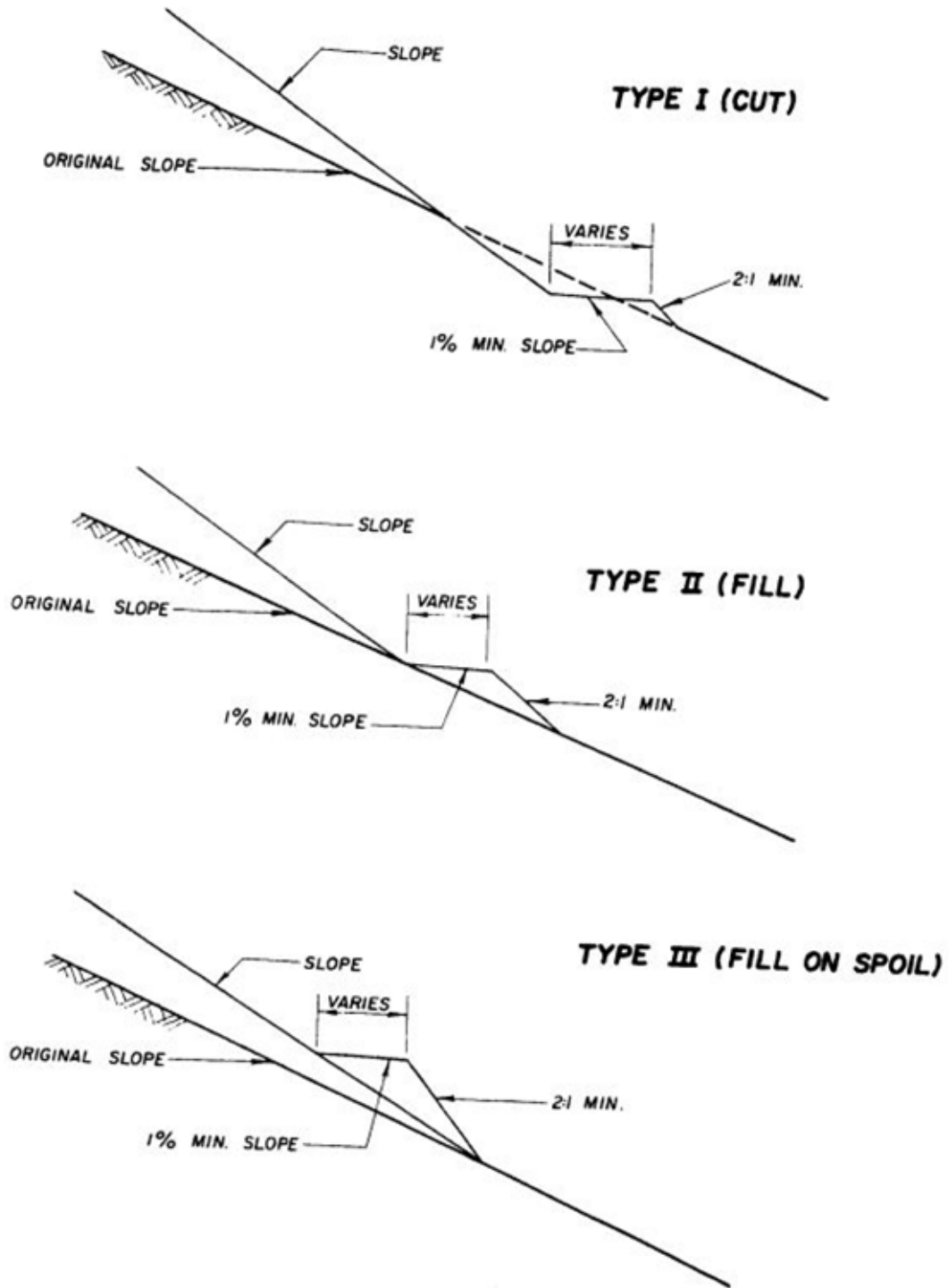

## **19.8 LEVEL SPREADER**

### **19.8.1 DEFINITION**

An outlet constructed at zero percent (0%) grade across the slope where concentrated runoff may be spread at non-erosive velocities over undisturbed areas stabilized by existing vegetation.

### **19.8.2 PURPOSE**

The purpose of the level spreader is to convert a concentrated flow of storm runoff into sheet flow and to outlet it onto areas stabilized by existing vegetation without causing erosion.

### **19.8.3 CONDITIONS WHERE PRACTICE APPLIES**

Level spreaders may be used where storm runoff is concentrated and diverted from surface mined areas onto undisturbed areas (i.e., at diversion outlets, etc.). This practice applies only in those situations where the spreader can be constructed on undisturbed soil and where the area directly below the level lip is stabilized by existing revegetation.

### **19.8.4 DESIGN CRITERIA**

A specific design for level spreaders will not be required. However, spreader length will be determined by knowing the peak rate of discharge (Q) Chapter 2, "Estimating Runoff" and utilizing Table selecting the appropriate length.

### **19.8.5 OUTLETS**

Final discharge will be over the level lip onto an area already stabilized by existing vegetation.

### LEVEL SPREADER

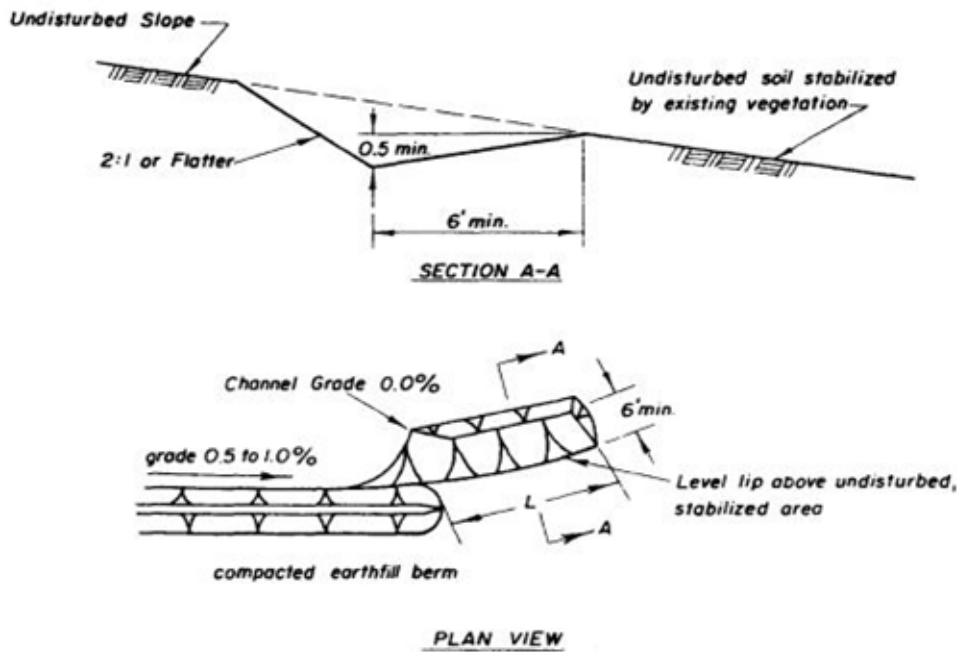

Designed Q (c f s)	Minimum Length ("L" in feet)
Up to 10	15
11 to 20	20
21 to 30	26
31 to 40	36
41 to 50	44

**GENERAL NOTES:**

1. All drawings Not to Scale.
2. Construct level lip on zero percent grade to ensure uniform spreading of storm runoff (converting channel flow to sheet flow)
3. Level spreaders must be constructed on undisturbed soil (not on fill).
4. Entrance to spreader must be graded in a manner to ensure that runoff enters directly onto the zero percent graded channels.
5. Storm runoff converted to sheet flow must outlet onto areas already stabilized by existing vegetation.
6. Periodic inspection and maintenance must be provided to ensure intended purpose is accomplished.

## 19.9 SKIMMER DEVICE

### 19.9.1 DEFINITION

Method or device which may be used on sediment control structures to prevent discharge during base flow conditions of coal fines, oil residue or other floating pollutants.

### 19.9.2 PURPOSE

A dewatering device preventing pollutants from entering reservoirs, ditches, diversions, waterways and streams.

### 19.9.3 CONDITIONS WHERE PRACTICE APPLIES

Usage of skimmer devices will only be utilized in those areas where there is a possibility that coal fines, oil residue or other floating pollutants will be in runoff entering sediment control structures.

### 19.9.4 DESIGN CRITERIA

The minimum design criteria for sediment control structures are as follows:

1. Drainage area less than 10 acres, the skimmer device shall be able to safely bypass a 10-year, 24-hour precipitation event in lieu of required exit channels on Excavated Sediment Pond, Dugout Type and Excavated Sediment Dam, Embankment Type.
2. Drainage areas larger than 10 acres, the skimmer device shall be able to safely bypass a 1-year, 24-hour precipitation event and provide an emergency spillway if structure is classified as an Excavated Sediment Dam, Embankment Type. If structure is classified as an Excavated Sediment Pond, Dugout Type, then a minimum of a 12-inch skimmer device will be required along with the minimum exit channel design.
3. Storage elevation of all structures shall be at the invert of the skimmer device.
4. It may be required to have anti-seep collars and trach racks installed on skimmer devices.

To determine what size corrugated steel pipe will be required to meet the standards set forth above, see Exhibit 13-3 of this handbook and given:  $K(e) = .9$ , head in feet (H) measured from the centerline of the outlet end to the top of water at the inlet side and minimum slope (S) of one percent (1%) to a maximum slope of three percent (3%).

## 19.10 PERFORATION

### 19.10.1 DEFINITION

A method which can be utilized on drop inlet, principal spillways, vertical riser, etc., to act as a dewatering device.

### 19.10.2 PURPOSE

Dewatering device of this type will allow additional detention for the structure, regulate the pool elevation during base flow conditions and allow for excess storage of runoff during storm events.

### 19.10.3 CONDITIONS WHERE PRACTICE APPLIES

Dewatering device such as perforation may be required on many erosion and sediment control systems such as the following:

1. Drop Inlet Type, principal spillways on Sediment Dams, Embankment Type or Excavated Sediment Dams, Embankment Type.
2. Vertical risers utilized on haulageways, bench control systems and regraded drainage control.
3. Types of drainpipe apparatus on sediment control structures so as to conduct periodical maintenance.

### 19.10.4 DESIGN CRITERIA

Drop Inlets, vertical risers or other methods when perforated shall be done so throughout the top two-thirds (2/3) of their length with 3/4-inch diameter holes spaced eight inches (8") vertically and 12 inches (12") horizontally center to center.

## 19.11 ROCK RIPRAP

### 19.11.1 DEFINITION

A layer of loose durable rock or aggregate placed over an erodible soil surface.

### 19.11.2 PURPOSE

The purpose of rock riprap is to protect the soil surface from the erosive forces of water.

### 19.11.3 CONDITIONS WHERE PRACTICE APPLIES

This practice applies to soil-water interfaces where the soil conditions, water turbulence and velocity, expected vegetative cover and groundwater conditions are such that the soil may erode under the design flow conditions. Rock riprap will be used, as appropriate, at such places as culvert outlets, stream bank protection grade checks, headwalls for culverts, spillways, entrance channels, flumes and etc.

### 19.11.4 DESIGN CRITERIA

The rock riprap will be placed in a 1.5-foot-thick blanket throughout the structure. Twenty five percent (25%) of the rock will be of 18 inches, the remaining seventy five percent (75%) shall

be well grade material (minimum 3 inches to maximum 18 inches) of sufficient rock small enough to fill the voids between the larger rock. The sized of rock will not be larger than the thickness of the rock riprap blanket. Shale shall not be used for riprap.

## **19.12 PUMPED WATER MANAGEMENT**

### **19.12.1 DEFINITION**

Pumped water management is the control of water being pumped on minim operations so that it will not be deleterious to the environment by eroding soil and providing sediment to downstream areas.

### **19.12.2 PURPOSE**

When there is a probable usage of a pumping system on a mining operation with a discharge either in diversion ditches, sediment structures, disturbed areas and fill slopes. Proper management of these systems must be considered to prevent additional contribution of suspended solids to the stream and in assisting the operation in meeting all existing State and Federal Water Quality Standards.

### **19.12.3 DESIGN CRITERIA**

Discharge of hose from pumping system may be outlet to the following:

1. Rock riprap structure
2. Dissipaters
3. Level spreaders
4. Any other methods for which will decrease the velocity to a safe, acceptable limit.

## **19.13 EXCELSION BLANKET**

### **19.13.1 DEFINITION**

The excelsior blanket is a protective blanket used in the establishment of vegetation in critical areas.

### **19.13.2 PURPOSE**

The use of a reinforcing weave, the intertwined nature of the excelsior and the fact that the blanket is secured to the soil by metal staples makes this product resistant to erosion by concentrated storm runoff. As a mulching product, it conserves soil moisture, serves as an insulator against solar radiation, dissipates energy form fallen raindrops and reduces erosion caused by overland flow.

### **19.13.3 CONDITIONS WHERE PRACTICE APPLIES**

The excelsior blanket may be used in critical areas such as swales, diversion, steep slopes, highly erodible soil, etc.

### **19.13.4 DESIGN CRITERIA**

In general, the blanket is rolled out on the seeded area to be protected and is stapled into place. Staple application rate under normal conditions is five staples per six linear feet of blanket, placed two along each side and one in the middle. Where more than one blanket is required, they are butt-joined and securely stapled.

### **19.13.5 DESCRIPTION**

The Erosion Control Excelsior Blanket consists of a machine produced mat of curled wood excelsior of eighty percent (80%) 8 inch or longer fiber length. It is of consistent thickness and the fiber is evenly distributed over the entire area of the Blanket. The top side of each Blanket is covered with 3 inch by 1 inch weave of twisted Kraft paper or biodegradable plastic mesh that has a high wet strength. Blankets are mold resistant and contain no chemical additives. The Blankets are available in 3 foot by 150 foot rolls and in 4 foot by 180 foot rolls. They are secured to the soil by the use of heavy duty wire staples.

## **19.14 MULCH BLANKETS**

### **19.14.1 DEFINITION**

Mulch blankets are used in the establishment of vegetation in critical areas such as diversion waterways, and etc.

### **19.14.2 PURPOSE**

As a mulching product they conserve soil moisture, serve as insulators against intense solar radiations, dissipate energy from falling rain and reduce erosion caused by overland flow. After application and saturation by rain, the fibrous blanket loosens to form a thick mulch cover. This cover and the underlying seed and soil are then held in place by the mesh plastic net. The fiber mulch blanket conforms to the surface to prevent erosion by wind and water.

### **19.14.3 CONDITIONS WHERE PRACTICE APPLIES**

Mulch blankets may be used on areas such as, but not limited to: Diversion ditches, stream channels, waterways, steep slope conveyances and flumes to protect the structure from erosion by wind and water until establishment of vegetation.

### **19.14.4 DESIGN CRITERIA**

Specific sites may require some modification or variation from the general criteria listed below. Manufacturer technical representatives or conservation specialists experienced in the

use of this product should be consulted for guidance. Both materials are designed to be unrolled and stapled over prepared, seeded soil surfaces. Where more than one roll of material is required, sufficient overlap should be provided to ensure against separation at these seams. Neither material should be stretched tight. They should be applied so as to conform to surface irregularities and must be in continuous contact with the soil surface. Material should be secured in depressions with additional staples. When used in areas that experience concentrated overland flow, fabric blankets must be extended laterally to an elevation that is several inches above the elevation of the design high flow.

## **19.15 JUTE NETTING**

### **19.15.1 DEFINITION**

Jute Netting is used in the establishment of vegetation in critical areas. Jute is a coarsely woven material of jute yarn which can be used to control soil erosion in waterways, diversion and on steep slopes.

### **19.15.2 PURPOSE**

As a mulching product, it conserves soil moisture, serves as an insulator against intense solar radiations, dissipates energy from falling raindrops and reduces erosion caused by overland flow. The thick strands and heavy weave enable this product to withstand the higher flow velocities associated with critical swales, diversion ditches, waterways, and etc.

### **19.15.3 DESIGN CRITERIA**

Prepare seedbed according to local specifications. Seeding may be split so that one-half (1/2) of seed is sown after the jute has been applied. Each specific site may require some modification or variation from the general criteria listed below. Manufacturer technical representatives or conservationists experienced in the use of this material should be consulted for specific guidance.

In general, start laying the thatching from the top of the channel and unroll downgrade so that one edge of the strip coincides with the channel center. Lay a second strip parallel to the first on the other side of the channel and allow a 2-inch overlap. If one roll of thatching does not extend the length of the channel, continue downhill with additional rolls.

Bury the top end of the jute strip in a trench 4 inches or more deep. Tamp the trench full of soil. Reinforce with a row of staples driven through the jute about 4 inches downhill from the trench. These staples should be about 10 inches apart. Then staple the overlap in the channel center. These staples should be 4 to 10 feet apart. The outside edges may be stapled similarly at any time after the center has stapled. Closer stapling along the sides is required where concentrated water may flow into the channel.

#### **19.15.4 DESCRIPTION**

Jute Netting is a heavy woven jute mesh of rugged construction. It is constructed of undyed and unbleached twisted jute fibers. It can be treated to be mold resistant. It is commonly available in individual rolls, 225 feet long and 4 feet wide. Each roll contains 100 square yards and weighs approximately 90 pounds.

### **19.16 NETTING**

#### **19.16.1 DEFINITION**

Netting is used as a means by which natural or synthetic fiber mulch can be securely anchored to seeded areas or areas temporarily stabilized with mulch on which conventional mulch tacking products are judged to be insufficient.

#### **19.16.2 PURPOSE**

Nettings are used to reinforce newly placed turf that may be subjected to severe runoff velocities before the root zone has matured to the point where turf structure above can withstand the anticipated stress.

#### **19.16.3 CONDITIONS WHERE PRACTICE APPLIES**

Nettings may be used on areas such as, but not limited to: Diversions, stream channels, waterways, steep slope conveyances, and flumes to protect the structure from erosion by wind and water until establishment of vegetation.

#### **19.16.4 DESIGN CRITERIA**

Generally, these products are unrolled and stapled on areas that have been mulched with natural and synthetic fiber mulch. Guidance can be secured from manufacturer's technical representatives or conservation specialists familiar with the use of these products.

When used to anchor newly placed sod, stapling becomes more critical and staple placement on 36 inch centers is often used. Netting with small openings is susceptible to heaving as the turf matures.

#### **19.16.5 DESCRIPTION**

Several products are on the market, and compositions range from tightly twisted Kraft paper yarns to polypropylene oriented plastic to fiber glass scrim. All are lightweight. The Kraft paper yarns are biodegradable. The polypropylene is ultraviolet sensitive and gradually disintegrates in the presence of sunlight. The polypropylene net and fiber glass scrim will not support combustion. All products are marketed in rolls. Roll widths range from 3.75 to 15 feet. Lengths range to 2500 feet.

## **19.17 ROCK RIPRAP FLUME**

### **19.17.1 DEFINITION**

A permanent rock riprap lined channel to conduct surface runoff from the top of a slope to the bottom of the slope.

### **19.17.2 PURPOSE**

To convey storm runoff safely down steep slopes without scouring or erosion damage.

### **19.17.3 CONDITIONS WHERE PRACTICES APPLIES**

Rock riprap flumes shall be used to convey surface water from the bench to a natural drainway and also in other locations where concentrated flows will produce erosion problems.

### **19.17.4 DESIGN CRITERIA**

#### **19.17.4.1 CAPACITY**

The flume shall be designed to carry the expected peak flow from a 10-year, 24-hour storm. To determine peak flow, see Chapter 2, "Estimating Runoff".

#### **19.17.4.2 SLOPE**

The maximum allowable slope shall be fifty percent (50%).

#### **19.17.4.3 ROCK RIPRAP**

To be in accordance with the standard and specifications for rock riprap as outlined in Chapter 19.

#### **19.17.4.4 DESIGN**

To obtain the required dimensions, see the following Table No. 1.

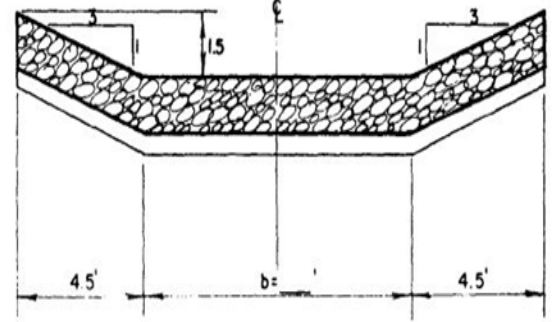
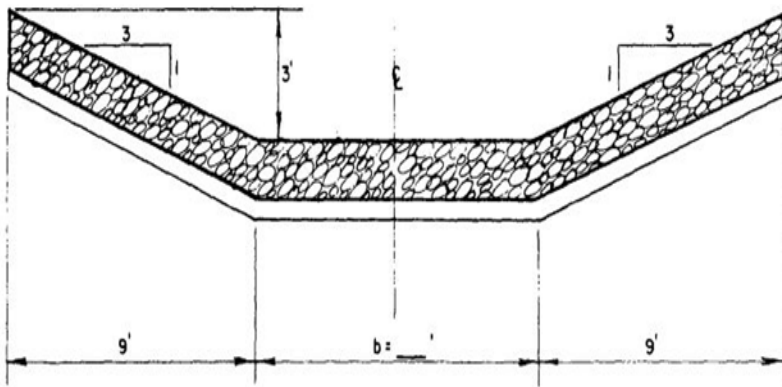
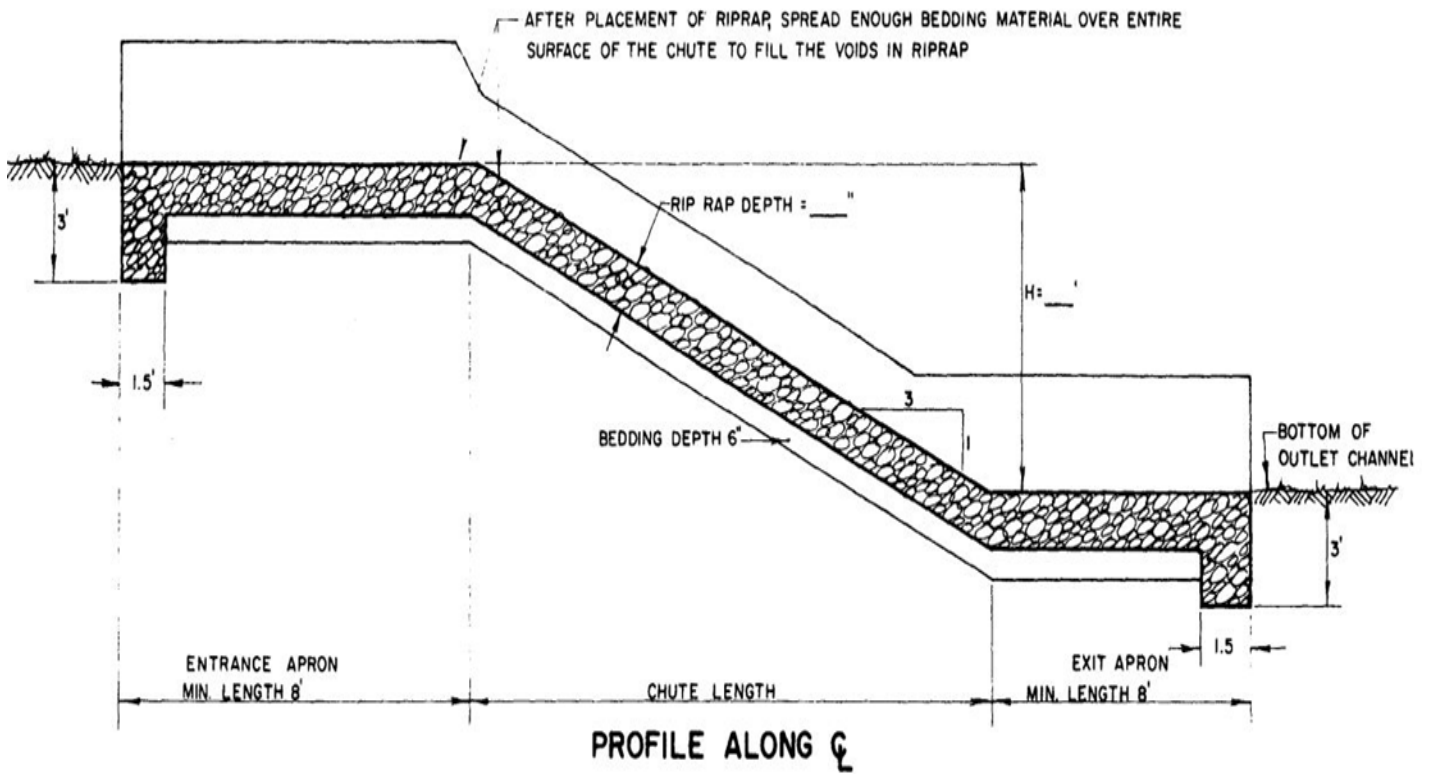

## ROCK RIPRAP FLUME

**TABLE 1**  
**ROCK RIPRAP FLUME REQUIRED DIMENSIONS**

<b>DISCHARGE (cfs)</b>	<b>BOTTOM (ft.)</b>	<b>SIDE SLOPE</b>	<b>CHUTE DEPTH (ft.)</b>	<b>INLET &amp; EXIT DEPTH (ft.)</b>
0-30	4	3:1	1.5	3.0
30-50	6	3:1	1.5	3.0
50-65	8	3:1	1.5	3.0
65-80	10	3:1	1.5	3.0
80-100	12	3:1	1.5	3.0

**19.18 FRENCH DRAINS**

**19.18.1 DEFINITION**

**19.18.2 PURPOSE**

A method to be utilized with the mining operation which could be incorporated in the regraded drainage control plan as required in Chapter 18.

**19.18.3 CONDITIONS WHERE PRACTICE APPLIES**

Mining operation areas can utilize this method in natural drainways or other areas where runoff above the operation can be conveyed through the backfill area safely.

**19.18.4 DESIGN**

French drain shall be a minimum of twelve (12) feet in width and composed of rock with a minimum dimension of twelve (12) inches. Rock drains cannot consist of more than ten percent (10%) fines as determined by visual inspection (fines being a material with a dimension of less than twelve (12) inches). When french drains are used in near horizontal positions of the bench, the drain will be a minimum of twelve (12) feet in height and extend safely through the backfill area and discharged safely. Also, when used in near vertical position of the highwall, there will be a minimum twelve (12) feet square drain extended to the top of the backfill to the near horizontal drain.

Rock material shall not consist of any coal waste, toxic forming or potential toxic forming materials.

Before construction of french drains located on the pit floor, special care shall be taken to ensure that the floor is completely clean.

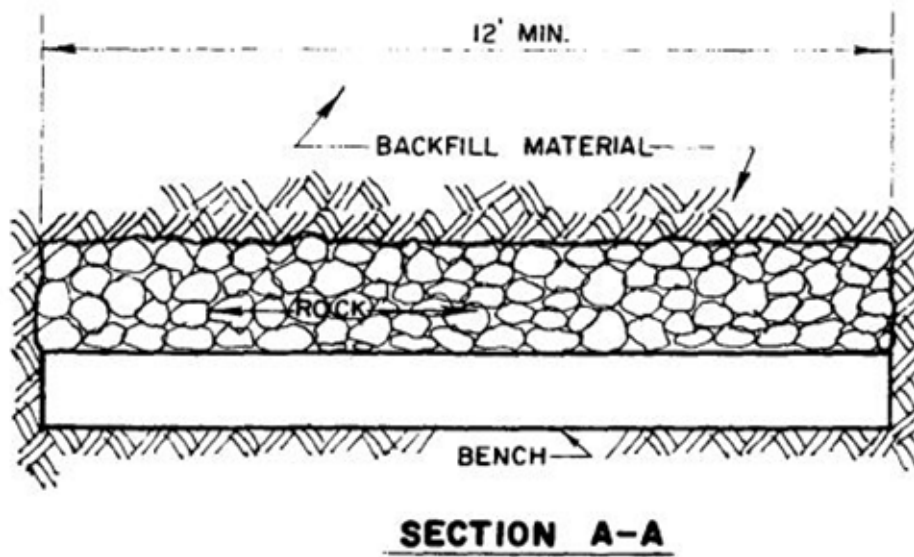
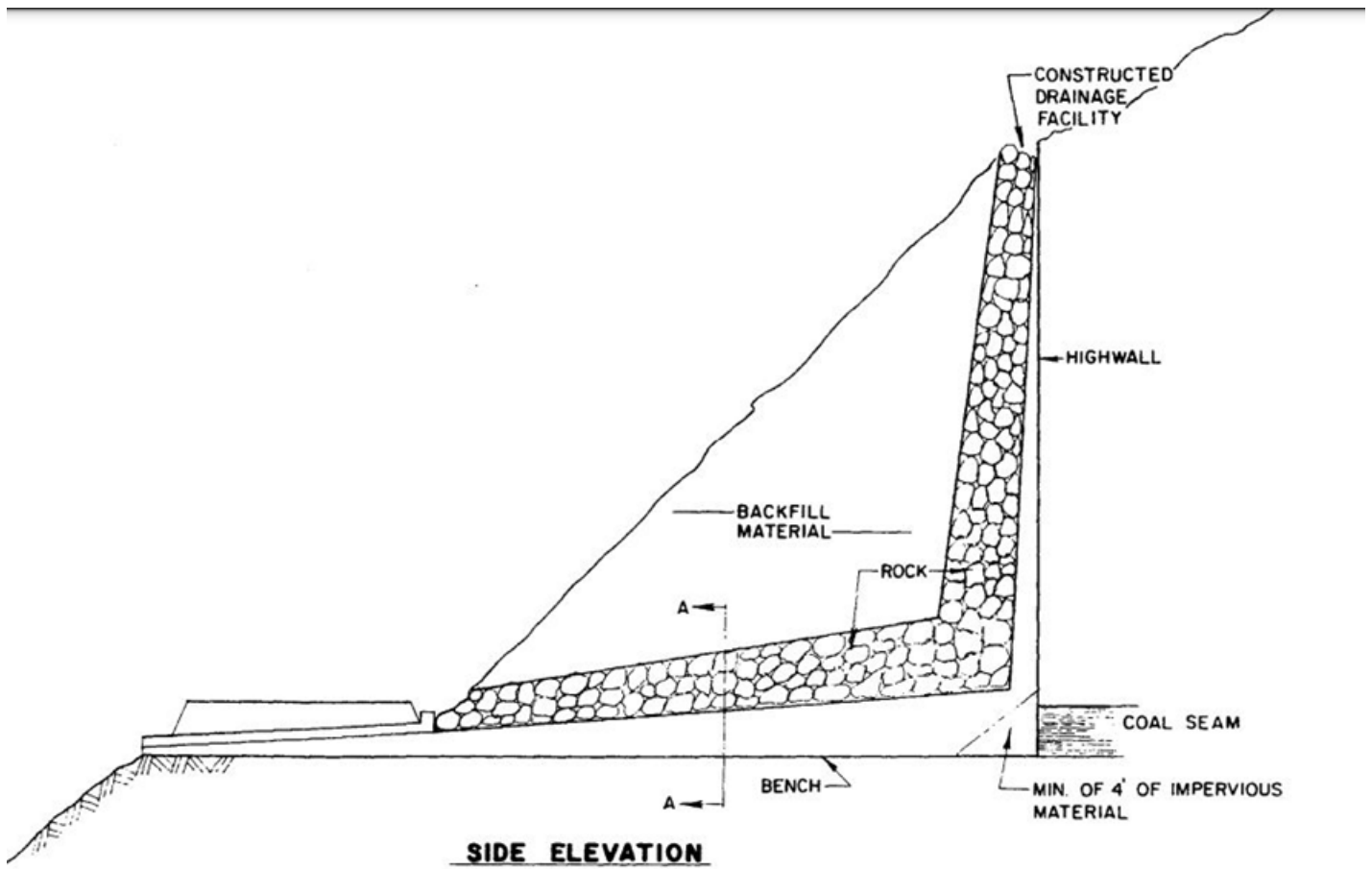

## 19.19 DESIGN REQUIREMENTS FOR ROCK RIPRAP

### 19.19.1 DEFINITION

A layer of loose rock or aggregate placed over an erodible soil surface to prevent erosion, scour or sloughing of a structure. Rock shall consist of non-degradable, non-acid or toxic forming rock such as natural sand and gravel, sandstone, limestone or other durable rock that will not slake in water and will be free of coal, clay or shale.

### 19.19.2 PURPOSE

The purpose of riprap is to protect the soil surfaces from the erosion forces of water.

### 19.19.3 CONDITIONS WHERE PRACTICE APPLIES

This practice applies to soil-water interfaces where soil conditions, water turbulence and velocity, expected vegetative cover and ground water conditions are such that the soil may erode under the design flow conditions. Riprap may be used, as appropriate, at such places as culvert outlets, diversion ditches, stream channels, emergency spillways, roadside ditches, embankment protections, entrance channels, etc.

### 19.19.4 SPECIFICATIONS

Rock riprap will be placed in a 1.5-foot-thick blanket on the structure. Twenty-five percent (25%) of the rock will be of 18 inches, the remaining seventy-five percent (75%) shall be well graded material (minimum 3 inches to maximum 18 inches) with sufficient amounts of rock small enough to fill the voids between the larger rocks. The size of rock will not be larger than the thickness of the rock riprap blanket. SHALE OR OTHER ROCK TYPES WHICH HAS A HIGH WEATHERING POTENTIAL SHALL NOT BE USED FOR RIPRAP.

### 19.19.5 DESIGN, IF APPLICABLE

This section shall apply to the designing of rock riprap size and criteria if the above specifications are not applicable.

The minimum design discharge for channels, spillway, ditches, and etc., shall be the peak discharge from the design storm, based on maximum watershed development during the life of the structure. The roughness coefficient,  $n$ , is used for determining flow on the constructed riprap surface as shown in Table 1.

In design of riprap-lined channels, The National Cooperative Highway Research Program Report No., 108, "Tentative Design Procedure for Riprap-Lined Channels", details the procedure for determining a design stone size is stable under the design flow conditions with a reasonable factor of safety. The design stone size which is exceeded in weight by fifty percent (50%), or median stone diameter, defined as that stone size which is exceeded in weight by fifty percent (50%) of the mixture.

Erosive forces of flowing water are greater in bends than in straight channels. Therefore, riprap size for bends and straights in the channel must be computed. If the riprap size [d(50)] computed for bends is less than ten percent (10%) greater than the riprap size for straight channel, then the riprap size for straight channels shall be considered to be of adequate size; otherwise, the larger riprap size shall be used in the bend. This is done in order to minimize the number of riprap sizes should be used on any single contract, in order to minimize construction problems caused by too many sizes. The riprap size to be used in a bend shall extend upstream from the point of curvature and downstream from the point of tangency a distance equal to five times the channel bottom width (length = 5b). This riprap size shall extend across the bottom and up both sides of the channel.

#### 19.19.5.1 RIPRAP

The riprap shall be composed of a well-graded mixture down to the 1 inch size particle, such that fifty percent (50%) of the mixture by weight shall be larger than the d(50) size. A well-graded mixture is defined as a mixture composed primarily of the larger stone sizes but with a sufficient mixture of other sizes to fill the progressively smaller voids between the stones. The diameter of the largest stone size in such a mixture shall be considered to be 1.5 times the d(50) size. The riprap size as shown on the plans and specifications or for other construction purposes shall be the size of the largest stone in the mixture, i.e., 1.5 X d(50). The minimum thickness of the riprap layer shall be 1.5 times the maximum stone diameter but not less than 6 inches. The riprap shall extend up the banks to a height equal to maximum depth of flow or to a point where vegetation can be established to adequately protect the channel.

In channels where there is no riprap or paving in the bottom, the toe of the bank riprap shall extend below the channel bottom a distance at least 1.5 times the maximum stone size, but in no case less than 1 foot. The only exception to this would be in the event that there is a non-erodible hard rock bottom. The channel bank shall not be steeper than 2.0 horizontal to 1.0 vertical.

After determining the riprap size that will be stable under the flow conditions, the engineer shall consider that size to be a minimum size and then, based on riprap gradations actually available in the area, shall select the size or sizes that equal or exceed the minimum size.

#### 19.19.5.2 FILTER

A filter is a layer of material placed between the riprap and the underlying soil surface to prevent soil movement into and through the riprap.

Riprap shall have a filter placed under it when either of the following conditions exist:

1. The riprap is not well graded down to the 1 inch size particle.
2. Riprap is placed on the side slopes of a channel and the soil is sand size or finer with a plasticity index, PI, less than 10. This requirement applies to slope having this soil in lenses or layers greater than 3 inches in thickness.

A filter can be of two general forms. One is a single layer of plastic filter cloth manufactured for that express purpose. Another is a properly graded layer of sand, gravel, or stone.

The criteria for the design of an aggregate filter are as follows:

$$\frac{d(15) \text{ Riprap}}{d(85) \text{ Filter}} \qquad \frac{d(15) \text{ Filter}}{d(85) \text{ Base}}$$

in which d(15) or d(85) is the size of base, filter or riprap material. In these equations, fifteen and eighty-five percent (15-85%), respectively, are finer. The base is the soil layer underneath the filter. The filter shall be graded down to sand size particles. Riprap 12 inches and larger shall not be dumped directly onto the plastic filter cloth, since it may tear or displace the filter cloth. Instead, a 4 inch minimum thickness blanket of gravel shall be placed over the filter cloth or the riprap shall be placed directly on the filter cloth by hand or by the bucket of the equipment. Side slopes shall be 1:1 or flatter to prevent the gravel from sliding down the filter cloth before placing the riprap.

### 19.19.5.3 SOIL SIZE CLASSIFICATION

Soil sizes given herein are according to the Unified Soil Classification as indicated:

<u>SOIL</u>	<u>SIEVE SIZE</u>
Gravel	Smaller than 3 inch and larger than #4 (Approximately ¼ inch)
Sand	Smaller than #4 and larger than #200 (0.074mm)

### 19.19.5.4 QUALITY

Stone for riprap shall consist of field stone or rough unhewn quarry stone of approximately rectangular shape. The stone shall be hard and angular and of such quality that it will not disintegrate on exposure to water or weathering, and it shall be suitable in all other respects for the purpose intended. The specific gravity of the individual stones shall be least 2.5.

Rubble concrete may be used, provided it has a density of at least 150 pounds per cubic foot and otherwise meets the requirements specified herein.

### 19.19.5.5 DESIGN PROCEDURES

The design of riprap-lined channels (National Cooperative Highway Research Program Report N. 108, "Tentative Design Procedure for Riprap-Lined Channels") is based on the tractive force method and covers the design of riprap in two basic channel shapes: Trapezoidal and triangular.

NOTE: This procedure is for the uniform flow in channels and is not to be used for design of riprap de-energizing devices immediately downstream from such high velocity devices as pipes and culverts.

Report No. 108 gives a simple and direct solution to the design of trapezoidal channels including channel carrying capacity, channel geometry, and riprap lining. The publication is a very good reference and design aid.

The procedure presented in this section is based on the assumption that the channel is already designed and the remaining problem is to determine the riprap size that would be stable in the channel. The designer would first determine the channel dimensions by the use of Manning's equation. The  $n$  value in Manning's equation is derived by estimating a riprap size and then determining the corresponding  $n$  value for the riprapped channel from Table 1.

When the channel dimensions are known, the riprap can be designed (or an already completed design may be checked) as follows:

#### 19.19.5.6 TRAPEZOIDAL CHANNELS

1. Calculate the  $b/d$  ratio and find the  $P/r$  on Figure 2.
2. From Table 1, using  $S(b)$ ,  $Q$ , and  $P/r$ , find the median riprap diameter,  $d(50)$ , for straight channels.
3. On Table 1, find the actual  $n$  value corresponding to the  $d(50)$  from step 2. If the estimated and actual  $n$  values are not in reasonable agreement, another trial must be made.
4. For channels with bends, calculate the ration  $B(s)/R(o)$  where  $B(s)$  is the channel surface width and  $R(o)$  is the radius of the bend. Use Table 4 to find the bend factor,  $F(B)$ . Multiply the  $d(50)$  for straight channels by the bend factor to determine riprap size to be used in bends. If the  $d(50)$  for the bend is less than 1.1 times the  $d(50)$  for the straight channel, then the size for straight channel may be used in the bend; otherwise, the larger stone size calculated for the bend shall be used.  
The riprap shall extend across the full channel section and shall extend upstream and downstream from the ends of the curve a distance equal to five times the bottom width.
5. From Table 5, determine the maximum stable side slope of riprap surface.

#### 19.19.5.7 TRIANGULAR CHANNELS

1. From Table 3A, using  $S(b)$ ,  $Q$  and  $z$ , find the median riprap diameter,  $d(50)$  for straight channels.
2. From Table 1, find the actual  $n$  value. If the estimated and actual  $n$  value are not in reasonable agreement, another trial must be made.

- For channel with bends, see step 4 under Trapezoidal Channels. The riprap size to be specified on the plans shall be the maximum stone size in the mixture which shall be 1.5 times the  $d(50)$ . The thickness of the riprap layer is 1.5 times the maximum stone size, but not less than 6 inches. Freeboard shall be added to the channel depth and shall be not less than 0.2 times the depth of flow, or 0.3 feet, whichever is greater.

Example:

Given:

Trapezoidal Channel

$Q = 100$  cfs  
 $S = 0.01$  ft./ft.  
 Side Slopes = 2.5:1  
 Mean bend radius,  $R(o) = 25$  ft.  
 $n = .033$  (estimated and used to design the channel to find that  $b = 6$  ft. and  $d = 1.8$  ft.)  
 Type of rock available is crushed stone:

Solution:

Straight Channel Reach

$b/d = 6/1.8 = 3.3$   
 From Table 2,  $P/r = 13.0$   
 From Table 3,  $d(50) = 3.4$  in.  
 From Table 1,  $n$  (actual) = 0.032, which is reasonably close to the estimated  $n$  of 0.033  
 Maximum riprap size =  $1.5 \times 3.4 = 5.1$  in.  
 Riprap thickness =  $1.5 \times 5.1 = 7.7$  in.  
 Use 5 in. as maximum riprap size and 8 in. as riprap layer thickness.

Channel Bend

$b(s) = b + 2zd = 6 + (2)(2.5)(1.8) = 15$  ft.  
 $b(s)/r(o) = 15/25 = 0.60$   
 From Table 4,  $F(B) = 1.33$   
 $F(B) = 1.33 > 1.1$ ; Therefore the bend factor must be used.  
 Riprap size in bend,  $d(50) = 3.4 \times 1.33 = 4.52$  in.  
 Maximum riprap size in bend =  $4.52 \times 1.5 = 6.78$  in.  
 Riprap thickness =  $6.78 \times 1.5 = 10.2$  in.  
 Use 7 inch for maximum riprap size and 10 inch for riprap layer thickness.

The heavier riprap for the bend shall extend upstream and downstream from the ends of the bend a distance of  $(5)(6) = 30$  ft.

The riprap for  $d(50) = 3.4$  in. and 4.52 in., which will both be stable on a 2.5:1 side slope (Table 5).

Freeboard = (0.2)(1.8) = .36 ft. which is not less than 0.3 ft. Therefore, minimum freeboard is 0.36 ft. Use 0.4 ft.

**19.19.5.8 CONSTRUCTION SPECIFICATIONS**

1. The subgrade for the riprap or filter shall be prepared to the required lines and grades. Any fill required in the subgrade shall be compacted to a density approximating that of the surrounding undisturbed material.
2. The rock or gravel shall conform to the specified grading limits when installed, respectively, in the riprap or filter.
3. Plastic filter cloth shall be protected from punching, cutting or tearing. Any damage other than an occasional small hole shall be repaired by placing another piece of cloth over the damaged part or by completely replacing the cloth. All overlaps, whether for repairs or for joining two pieces of cloth, shall be a minimum of one (1) foot.
4. The stone for the filter and riprap may be placed by equipment. Both filter and riprap shall each be constructed to the full course thickness in one operation and in such a manner to avoid displacement of the underlying material. The stone for filter and riprap shall be delivered and placed in a manner that will ensure that the filter and riprap each shall be reasonable homogeneous with the smaller stones and spalls filling the voids between the larger stones. Riprap shall be placed in a manner to prevent damage to the filter blanket. Hand placing will be required to the extent necessary to prevent damage to the permanent works.

**TABLE-1 MANNING'S "n" FOR RIPRAP-LINE CHANNELS**

$$n = 0.0395 [d(50)]^{1/6}$$

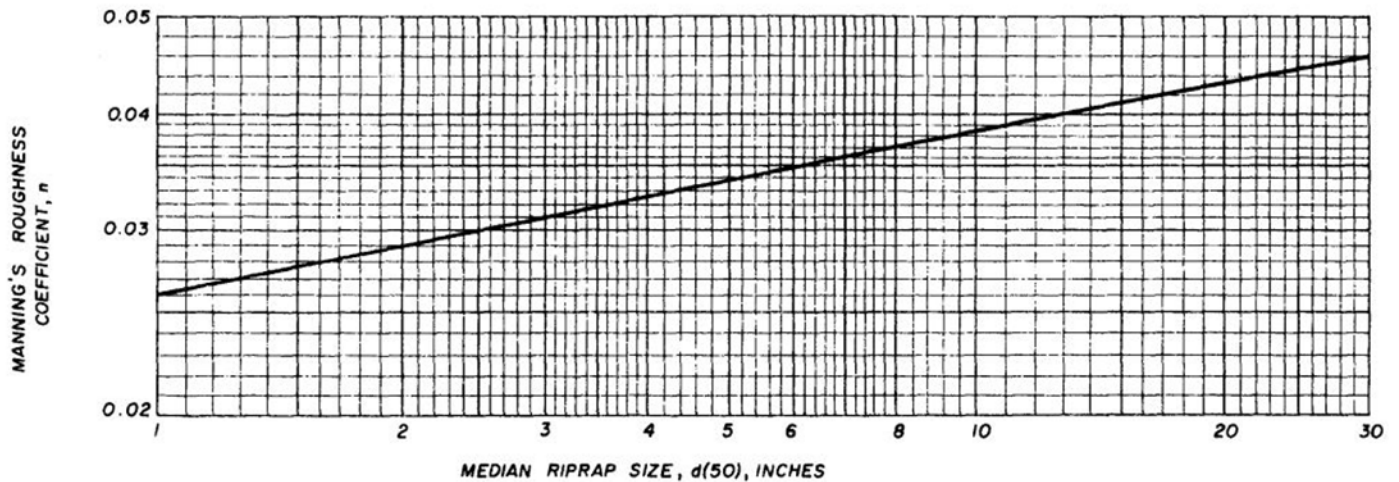
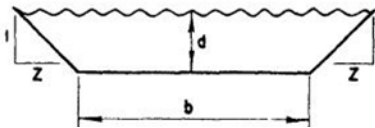
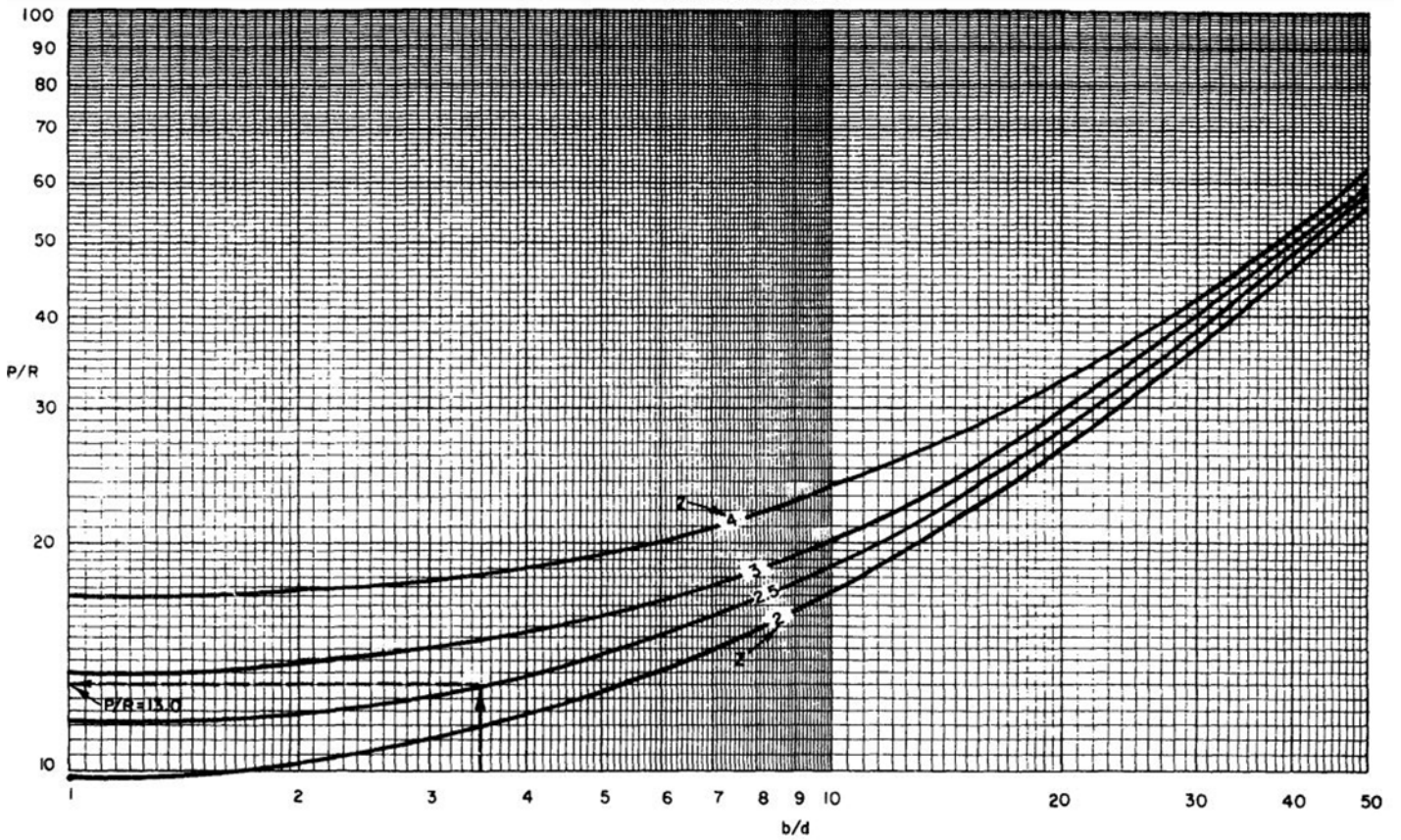

TABLE 2 – RELATIONSHIP OF P/R TO b/d IN TRAPEZOIDAL CHANNELS

P/R FOR TRAPEZOIDAL CHANNELS



$$P/R = \frac{\text{WETTED PERIMETER}}{\text{HYDRAULIC RADIUS}}$$

TABLE - 3

MEDIAN STONE DIA., d/50, IN INCHES

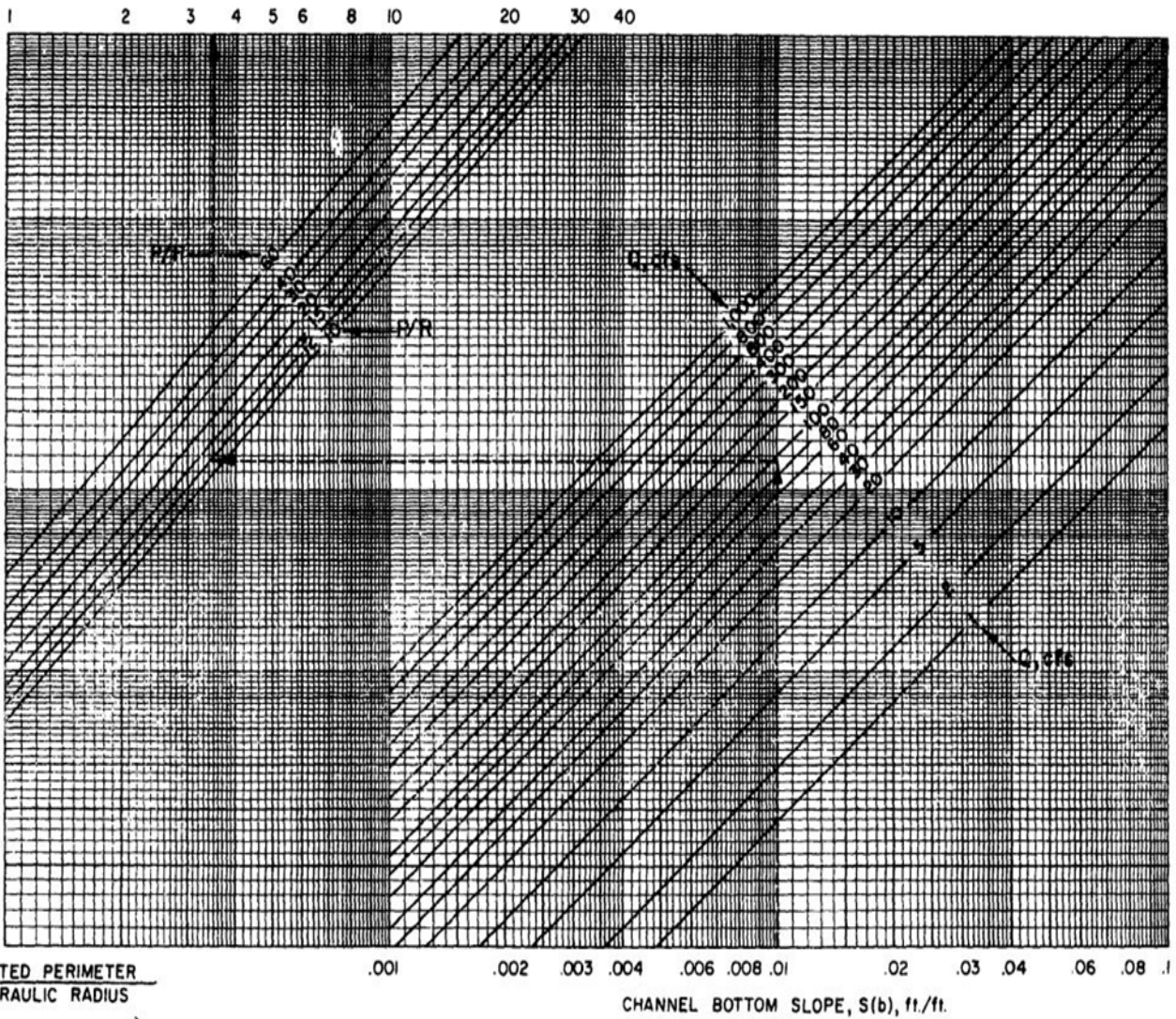

$$P/R = \frac{\text{WETTED PERIMETER}}{\text{HYDRAULIC RADIUS}}$$

$$d(50) = 12 \left( 118.0 S(b)^{13/6} R/P \right)^{2/5}$$

Adapted from Highway Research Report No.108

MEDIAN RIPRAP DIAMETER FOR STRAIGHT TRAPEZOIDAL CHANNELS

**TABLE 3A**  
**MEDIAN STONE DIA., d (50), IN INCHES**

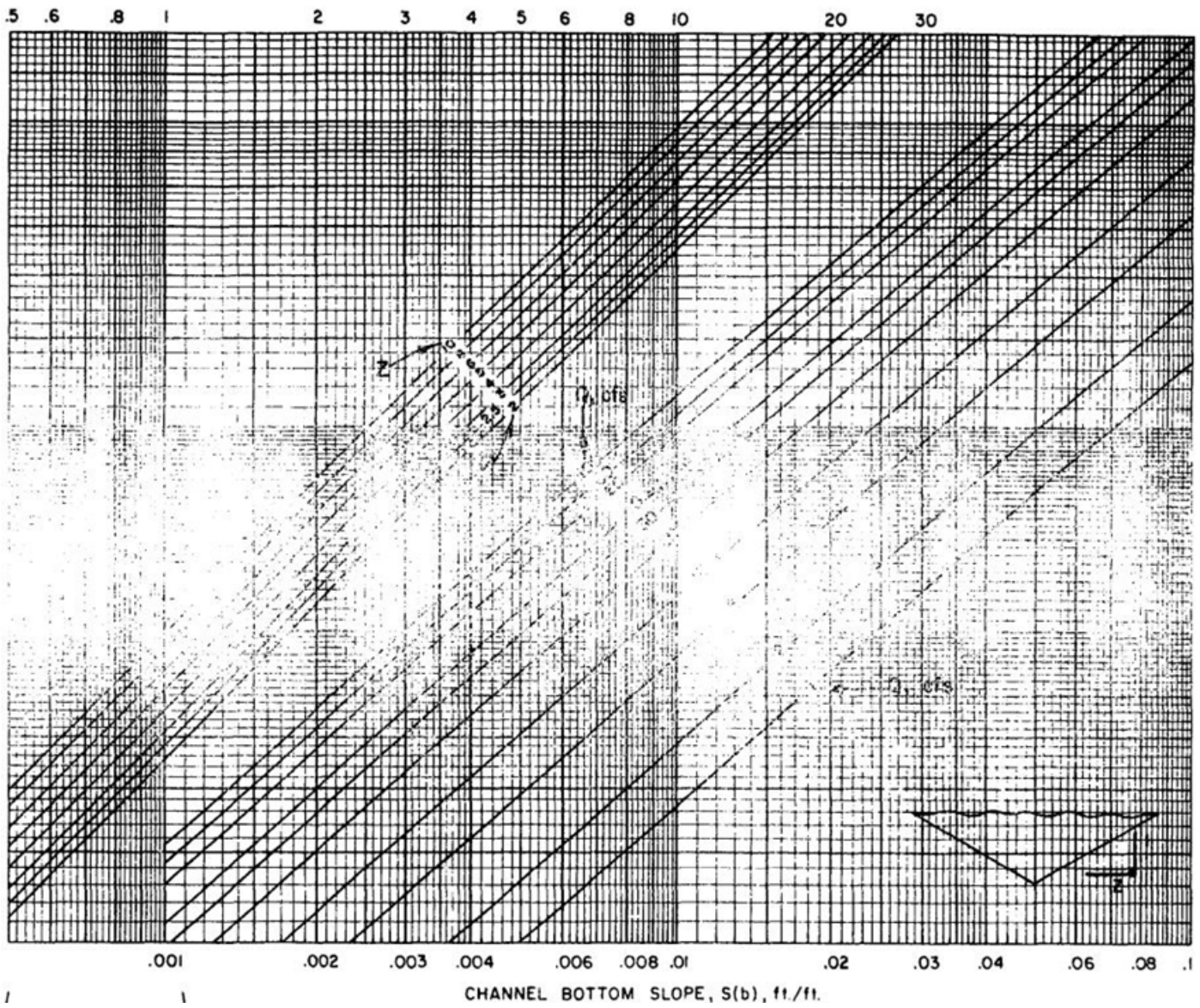

$$d(50) = 12 \left( 64.4 Q S(b)^{13/6} \frac{Z}{Z^2 + 1} \right)^{2/5}$$

Adapted from Highway Research Report No.108

TABLE 4

RIPRAP SIZE CORRECTION FACTOR FOR FLOW IN CHANNEL BENDS

$d(50) \text{ (FOR BEND)} = d(50) \text{ (FOR STRAIGHT)} \times F(B)$

$B(s)$  = CHANNEL SURFACE WIDTH

$R(o)$  = MEAN RADIUS OF BEND

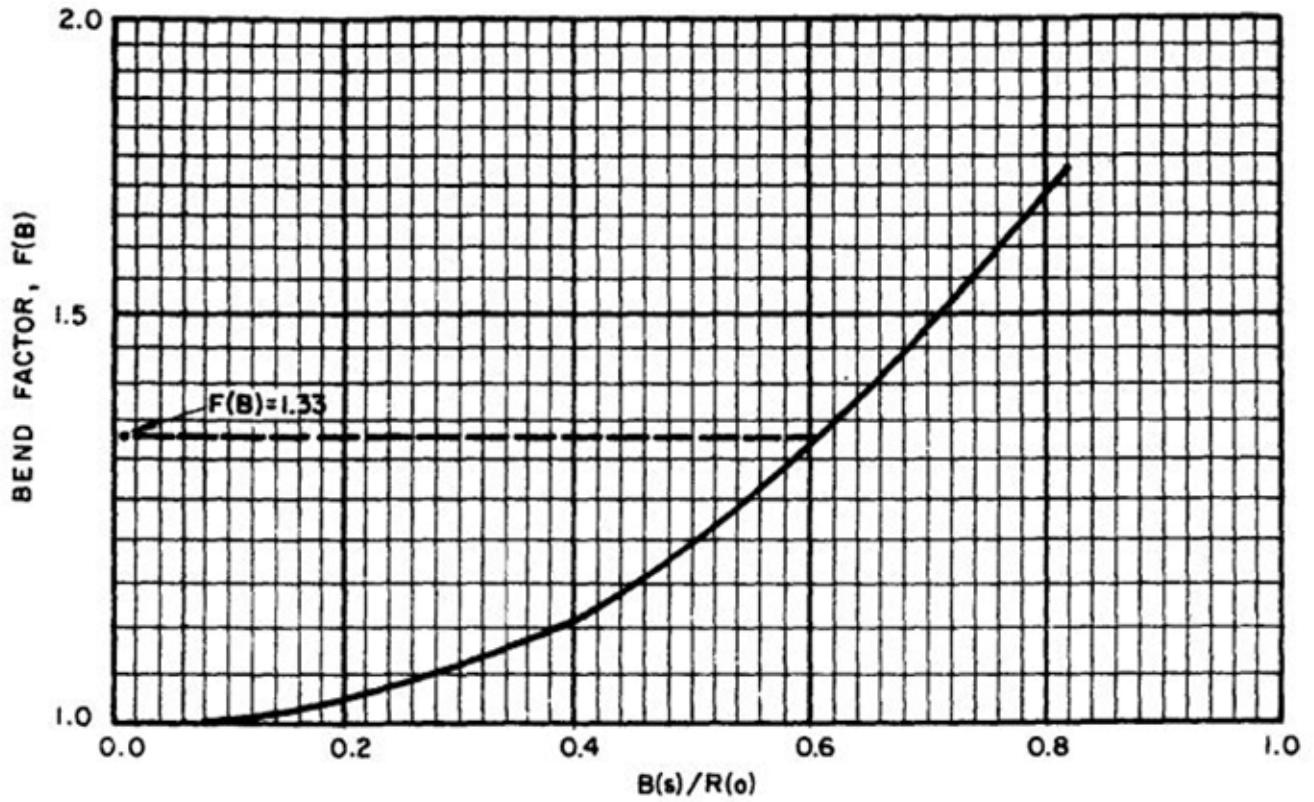

**TABLE 5**  
**MAXIMUM RIPRAP SIDE SLOPE WITH RESPECT TO RIPRAP SIZE**

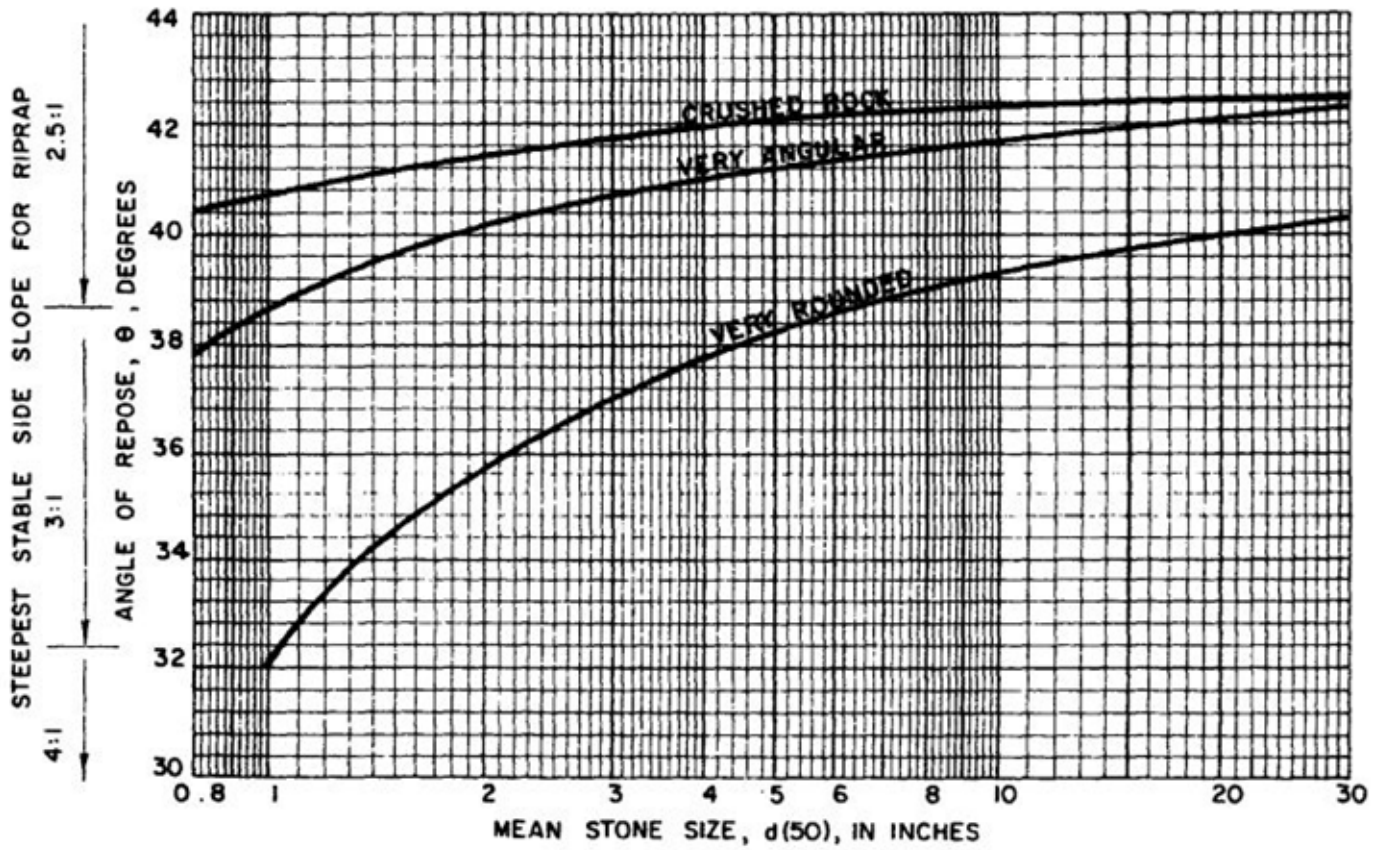

# 20 Revegetation

## CONTENTS

Definition	1	Attachment 1	13
Purpose	1	Attachment 2	16
Conditions where Practice Applies	1	Attachment 3	18
Procedures for Evaluating Vegetative Cover	1	Attachment 4 – <i>Memorandum from Lewis A. Halstead</i>	21
<i>Modified Rennie-Farmer Method</i>	1	Attachment 5	25
<i>Vegetation</i>	1	Table 3	29
<i>Woody Vegetation</i>	1	Table 4	30
<i>Non-Woody Vegetation</i>	2	Table 5	31
<i>Rules and Regulations</i>	3	Figure 1, Figure 2, and Figure 3	32
<i>Vegetative Cover</i>	4	Figure 4 and Figure 5	33
<i>Revegetation Plan</i>	4	Figure 6 and Figure 7	34
<i>Planting Plan</i>	5	Figure 8	35
<i>Soils</i>	5	Figure 9	36
<i>Topsoil</i>	6	Figure 10	39
<i>Documentation of Vegetative Cover Requirements</i>	7	Table 1	41
<i>Optimum Times – For Spring &amp; Fall Seeding</i>	7	Exhibit 1	42
<i>Vegetation requirements related to Phase Release</i>	8	Approved Woodland Plant Mixtures	44
<i>Post Mining Land Use</i>	8		
<i>Vegetation Specific Requirements of Post Mining Land Use</i>	10		

## REVEGETATION

### 20.1 DEFINITION

The process of establishing plants on disturbed or barren land, from which the plants have been removed.

### 20.2 PURPOSE

To quickly establish a vegetative cover on all disturbed areas to minimize erosion, provide economic benefits and restore an aesthetic appeal. In a manner that causes vegetation to become self-propagating and resumes natural processes.

### 20.3 CONDITIONS WHERE PRACTICE APPLIES

Revegetation will be concurrent with the operation as mining and backfilling progresses and be carried out in a manner that encourages a prompt vegetative cover and recovery of productivity levels compatible with the approved post mining land use. (PMLU)

### 20.4 PROCEDURES FOR EVALUATING VEGETATIVE COVER

#### **Rennie and Farmer technique:**

**<https://dep.wv.gov/dmr/handbooks/Documents/OSM%20Technical%20Guides.pdf>**

#### 20.4.1 Vegetation

Establishing vegetation is an important activity in reclaiming mined lands. Revegetation encourages minesoil development, creates an aesthetically pleasing landscape, and contributes to productive postmining land use. These plants should establish quickly, stabilizing the disturbed area protecting the soil from erosion and greatly reducing sediment runoff from disturbed areas. These plants both woody and nonwoody provide food and shelter to wildlife species and are necessary to restore and maintain ecological function to reclaimed sites. Prompt and thorough establishment of vegetation after mining is essential to comply with the federal Surface Mining Control and Reclamation Act (SMCRA) by coal-mining operations.

##### 20.4.1.a. Woody Vegetation

Woody vegetation is an important part of the reclamation planting plan and should be included where acceptable and appropriate. It must be noted that Commercial Forestry post mining land use has strict requirements on species and stocking rates found in the West Virginia Surface Mine Reclamation Rules. Fish and Wildlife Habitat and Recreation lands, and Forestland post mining land uses also have species and stocking rate requirements with exceptions. The “Rules” and the permit application should be consulted in conjunction to determine if an exception to the species and stocking rate requirements would apply to a specific

permit for Fish and Wildlife Habitat and Recreation lands or Forestland post mining land uses.

More than 100 native tree species and numerous native shrub species grow within Appalachian forests. Aspect and topography are the primary factors to consider when selecting tree species for planting. Aspect is the direction that a slope faces. Slopes facing south receive more solar radiation than north-facing slopes. While east and west-facing slopes receive similar amounts of sunlight, the west-facing slopes receive sunlight during the hottest part of the day – mid and late afternoon. As a result, slopes with south and west aspects have drier soils than those that face north and east. Northeast- and east-facing slopes are generally most favorable for tree growth because of higher levels of soil moisture, while southwestern slopes are generally least favorable because of their dryness. Topography will influence soil moisture availability. Steep slopes are drier than more gentle slopes because they shed more rainfall as runoff, allowing less water to infiltrate the soil. Large, uncompacted, flat areas on mine sites can provide moist soil conditions and good growth potential; while landscape channels, depressions, and stream banks will have wetter soil conditions. Many of the tree and shrub species have showy flowers which attract pollinator species, which are essential to proper ecological function. They also provide food for numerous wildlife species of birds and mammals whether as direct forage, valuable winter browse or from consumption of fruits and/or seeds.

#### 20.4.1.b. Non woody vegetation

When establishing vegetative groundcover on surface mined sites, the two most important factors influencing species selection should be soil properties and postmining land use. Two general categories of non woody plants are used for revegetation of mined areas: grasses and forbs.

Forbs – herbaceous flowering plants – are generally used in mine revegetation in conjunction with grasses. Forbs usually have broad leaves, flowers, and a branching taproot system. Forbs can be further classified as legumes and nonlegumes. Legumes are forbs that belong to the Leguminosae family. Legumes are especially important for revegetating mined lands because they can use nitrogen from the air to meet their nitrogen nutrition requirements, and they can transfer this “fixed” nitrogen to other components of the plant/soil system. A healthy population of legumes is essential to successful revegetation, especially on minesoils with approved topsoil substitutes which are deficient in plant-available nitrogen. Non leguminous forbs are also broad-leaved plants with showy flowers. Examples of non-leguminous forbs used in revegetation are buckwheat (*Fagopyrum sagittatum*), sunflowers (*Helianthus* spp.). These flowering plants attract pollinator species, which are essential to proper ecological function. They also provide food for numerous wildlife species of birds and mammals whether as direct forage, or from consumption of fruits and/or seeds.

Grasses belong to the Gramineae family, produce large amounts of biomass, and are adapted to initiate regrowth rapidly after mowing or grazing. Grasses have fibrous root systems that hold soil in place, thereby controlling erosion. One of the most important functions of the Surface Mining Reclamation and Control Act (SMCRA) is stabilizing soil and controlling erosion. Erosion control is a concern due to the earth moving construction related to surface mining, minimizing sediment leaving the permitted area is priority. Excessive sedimentation has severe negative effects on the surrounding aquatic environment. Several grasses are well-adapted to the infertile, droughty, and/or acidic sites often associated with mined areas; others can provide high-quality hay and forage. A healthy grass component is important to successful erosion control. Many species can produce large amounts of biomass in a short time and respond quickly to fertilizer and management, while other species may be slower growing and persist on the site for long periods without management. For these reasons, a good revegetation program will always contain grasses as a major component of the seed mix.

#### 20.4.2 Rules and Regulations

It is encouraged to plant native species within the reclaimed area and minimize or eliminate the planting of non-native species. Many introduced species do not survive or reproduce outside of human care. Most of those that can, do not cause ecological detriments. There are those though, that possess characteristics that allow them to quickly colonize large areas of their new environments. Due to availability issues of some native species in the past, a lot of non-native species were planted. In recent times those issues have diminished and there is a growing popularity in reestablishing native species on disturbed sites. This has broadened the spectrum of plants that are available and many native species that once were hard to come by are readily available or can be found with minimal effort.

The WV Surface mining reclamation rules states that, “alternate species of trees, shrubs, grasses, legumes, or vines may be substituted for native species if approved by the secretary.” Substitute species may be approved if the following conditions are satisfied:

- the species are compatible with the plant and animal species of the region and are necessary to and compatible with achieving the approved postmining land use.
- the species meet the requirements of applicable state and federal seed, poisonous and noxious plant, or introduced species laws and regulations.

The West Virginia rules dealing with noxious weeds are found in Title 61 Series 14A of the legislative rules. These list any plants that are prohibited within the state of West Virginia and can be referred to for any clarifications. Autumn Olive was the most recent addition to the WV noxious weed and plant list and should not be included in any planting plan or proposed for any mine site. The current WV noxious

weed and plant list along with a link to the Federal noxious weed list is included in Attachment 1.

#### 20.4.2.a. Vegetative Cover

A diverse and permanent vegetative cover of the same seasonal variety native to the area of disturbed land or introduced species that are compatible with the approved postmining land use must be established on all regraded areas and all other disturbed areas. Reforestation opportunities should be maximized for all areas when appropriate. All revegetation plans shall include a map identifying areas to be reforested, planting schedule and stocking rates.

The established vegetative cover shall:

- stabilize and protect the soil from erosion.
- be capable of regeneration and plant succession.
- kept concurrent with backfilling and grading.
- compatible with the approved postmining land use
- temporary vegetative cover should be in place by the end of the first growing season.
- A permanent vegetative cover should be in place by the end of the second growing season.

#### 20.4.2.b. Revegetation plan

A complete revegetation plan should be made a part of each permit application. The revegetation plan should be developed in a manner which is compatible with the following requirements:

- Plant species and seed mixtures that are quick growing and enrich the soil, of the same seasonal variety of naturally occurring vegetation, must include at least one herbaceous legume species.
- species should be compatible with the plant and animal species of the region and the approved post mining land use.
- species should comply with State and Federal seed, poisonous and noxious plants, and introduced species, laws and rules and regulations.
- If the premining and postmining land uses are cropland, planting of the crops normally grown will meet the species requirements.
- contain a statement asserting that rills and gullies which form in areas that have been regraded and topsoiled will be filled, regraded, stabilized, topsoiled, and reseeded or replanted.
- revegetation plan shall specify that areas where excessive erosion is likely to occur the operator will rapidly establish temporary vegetation cover. This may include but is not limited to areas around sediment control structures, haulage ways, stockpiles, storage areas, etc.

- plan shall include a map identifying areas to be reforested, planting schedule and stocking rates.

20.4.2.c. Planting plan

The revegetation plan must contain a planting plan made up of the following:

- A prediction of the mine soil character based on overburden analysis, soil analysis, and other available information.
- The proposed treatment to neutralize acidity.
- The method of mechanical seed bed preparation
- The application rates and types of mulch, application rates and analysis of fertilization the application rates and species of perennial vegetation including herbaceous and woody plants in accordance with the appropriate sources
- The areas to be planted or seeded to trees and shrubs.
- The land use objective and a maintenance schedule

20.4.3. Soils

The following minimum standards for soil treatment and amendments apply to all applications:

- 600 lbs/ac of 10-20-10 or 10-20-20 fertilizer. based on soil analysis performed by a qualified soils laboratory Alternatives may be approved.
- Lime rates should be such that a uniform soil pH of 6.0 will be achieved. Alternatives based on the optimum pH for the revegetation species may be approved.
- Approved materials and minimum rates for mulch to be applied are as follows.

Material	Rate/Acre
Straw or hay	1 ½-2 tons
Wood Fiber or Wood Cellulose	1,000 lbs.
Shredded Bank	50 cubic yards

Adhesives or tackifiers may be used with wood fiber or wood cellulose at the rates indicated in below:

Minimum Rate/Acre for Wood Fiber or Wood Cellulose

Material	Rate/Acre	
Genaqua 743	25 gallons	500 lbs.
Curasol AK or HA	25 gallons	500 lbs.
Aerospray 70	25 gallons	500 lbs.

The operator should take into consideration the following characteristics of the mine soil:

- Fertility
- Stoniness
- Texture
- Steepness of slope
- Standard field and laboratory overburden analysis
- Premining overburden analysis

Mine soils with a history of acidity or other vegetative limiting chemical parameters should be analyzed by a qualified soils laboratory. The results should be considered and remediated appropriately in the final planting plan.

20.4.3.a. Topsoil

Topsoil should be removed separately and be redistributed, or it should be segregated and stockpiled in a separate stable location as specified in the Revegetation and Planting plans. Stockpiled topsoil should be stabilized, protected from erosion, and remain in place until used for redistribution. Topsoil and other materials should be redistributed in a manner that prevents excess compaction and that achieves an approximate uniform, stable thickness, consistent with the approved postmining land uses. Immediately after redistribution all topsoil areas should be protected from erosion.

Topsoil Substitutes may be approved if it is determined by the results of appropriate chemical and physical analysis of overburden and topsoil, which include analysis of:

- Depth
- Thickness
- Areal extent (substitute structure or soil horizon)
- Ph
- Texture class
- Percent coarse fragments

- Nutrient content that the proposed substitute is:
  - capable of supporting and maintaining the approved postmining land use.
  - the proposed substitute material is equally suitable for sustaining vegetation as the existing topsoil.
  - resulting soil medium is the best reasonably available in the permit area to support vegetation.
  - analyses were conducted using standard testing procedures.

A certification of analysis made by a qualified laboratory must be provided for all the above to properly approve a topsoil substitute.

#### 20.4.4. Documentation of Vegetative cover Requirements

Any amendments or modifications to the planting plan which reflect major changes in seeding or planting rates and species composition should be submitted as a permit revision. A final planting plan report should be submitted to the Secretary within sixty (60) days after Phase 1 bond reductions.

The report should contain:

- actual acreage planted.
- application rates of soil amendments
- seed and seedlings mixtures and rates.

A subsequent and separate report may be filed after the tree plantings are completed during the appropriate planting season, as opposed to one report with grasses, legumes, and woody plants.

It is the responsibility of the operator to review all areas which were seeded and/or planted during previous plantings and to establish the required level of vegetation success. The vegetative cover should be capable of regeneration and plant succession, or made up of perennial plants, capable of multi-year survival. This relates to both grasses and legumes (non woody species) and trees and shrubs (woody vegetation) there are times when seeding and establishing plants is more favorable and times when it is less favorable. Temporary vegetative cover may be appropriate as mixtures of annual quick growing species will provide erosion and soil protection, until favorable seeding times develop.

#### 20.4.5. Optimum Times – For spring and fall seeding are:

Spring: February 1 – April 30

Fall: September 15 – November 15

This does not imply nor is it a requirement that seeding or planting may only be conducted within the time frames of these dates. There may be times when seeding is desired or

necessary outside of these dates, these dates are considered more favorable for successful plant growth and survival. The operator is responsible for establishing the required level of vegetative success and supplemental seeding and planting may be necessary to achieve that level of success. (See Attachment 2 & 3 for some recommended species and planting rates)

#### 20.4.6. Vegetation requirements related to Phase Release

##### 20.4.6.a. Phase II Bond Release

Two (2) years or more after the last date of augmented seeding, the Secretary may conduct a vegetative inspection to verify that applicable standards for vegetative success have been met. The operator may request inspection for release and provide the Secretary with a vegetative evaluation using a statistically valid sampling technique with a ninety (90) percent statistical confidence interval (see attachments 4 & 5). An inspection report should be filed for each release inspection and when the standard is met, the Secretary should execute a Phase II bond release.

One exception to this rule is Commercial Forestry post mining land use which may not be granted phase II release before the end of the fifth tree growing season.

##### 20.4.6.b. Phase III Bond Release

After five (5) growing seasons following the last augmented seeding, or 3 growing seasons following Phase II bond release the operator may request a final inspection and final bond release Secretary should conduct an inspection to verify the final vegetative evaluation using approved, statistically valid sampling techniques. A final report should be filed and if the applicable standards have been met, the Secretary should execute a Phase III bond release and discharge the remainder of the bond. All evaluated parameters will be considered equal to the approved success standard when they are 90 (ninety) percent or more of the success standard.

One exception to this rule is Commercial Forestry post mining land use. Phase III bond release may not be authorized unless commercial forestry productivity has been achieved by the end of the twelfth growing season or if such productivity has not been achieved a commercial forestry mitigation plan is submitted to the Secretary approved and completed.

#### 20.4.7. Post Mining Land Use

Post mining land use designation is pertinent to vegetation and the Land use categories are as follows.

- a. **Heavy Industry.** Manufacturing facilities, power plants, airports, or similar facilities.

- b. **Light Industry and Commercial Services.** Office buildings, stores, parking facilities, apartment houses, motels, hotels, or similar facilities.
- c. **Public Services.** Schools, hospitals, churches, libraries, water treatment facilities, solid waste disposal facilities, public parks and recreation facilities, major transmission lines, major pipelines, highways, underground and surface utilities and other servicing structures and appurtenances.
- d. **Residential.** Single and multiple-family housing (other than apartment houses) with necessary support facilities. Support facilities may include commercial services incorporated in and comprising less than five percent (5%) of the total land area of housing capacity, associated open space and minor vehicle parking and recreation facilities supporting the housing.
- e. **Cropland.** Land used primarily to produce cultivated and close-growing crops for harvest alone or in association with sod crops. Land used for facilities in support of farming operations are included.
- f. **Bio-oil fuel Cropland.** Agricultural production of renewable energy crops through long-term intensive cultivation of close-growing commercial biological oil species (such as to include but not limited to soybeans, rapeseed or canola) for harvest and ultimate production of bio-fuels as an alternative to petroleum based fuels and other valuable products;
- g. **Rangeland.** Includes rangelands and forestlands which support a cover of herbaceous or scrubby vegetation suitable for grazing or browsing use.
- h. **Hayland or pasture.** Land used primarily for the long-term production of adapted, domesticated forage plants to be grazed by livestock or cut and cured for livestock feed.
- i. **Fish and wildlife habitat and recreation lands.** Wetlands, fish and wildlife habitat, and areas managed primarily for fish and wildlife or recreation; or
- j. **Forestland.** Land with at least a twenty-five percent (25%) tree canopy or land at least ten percent (10%) stocked by forest trees of any size, including land formerly having had such tree cover and that will be naturally or artificially reforested.
- k. **Commercial Forestry.** Where forest cover is managed for commercial production of timber products.
- l. **Impoundments of water.** Land used for storing water for beneficial uses such as stock ponds, irrigation, fire protection, recreation, or water supply.
- m. **Combined uses.** Any appropriate combination of land uses where one land use is designated as the primary land use and one or more other land uses are designated as secondary land uses.

#### 20.4.8. Vegetation Specific requirements of Post Mining Land Use

The land use categories, particularly post mining land uses (PMLU), may have specific requirements for revegetation of the site. Depending on the PMLU, general revegetation requirements may be all that is necessary. On the other hand, some PLMU's have more detailed specifications, which apply to vegetation. These PMLU specific vegetation requirements will overrule general requirements when they differ. The following is an explanation of PMLU specific revegetation requirements along with the Land Use Category to which they apply.

Hayland and Pasture post mining land use the general requirement that legumes and perennial grasses on the site should achieve at least a ninety (90) percent ground cover and a productivity level as set forth by the Secretary during any two years of the responsibility period except for the first year. Substandard areas should not exceed one-fourth (1/4) acre in size nor total more than ten (10) percent of the area seeded.

Exceptions to this general standard may be authorized by the Secretary based on the Post Mining land Use as per the following exceptions.

Heavy Industry, Light Industry, Public Services or Residential post mining land use less than two (2) years after regrading is completed, the ground cover of living plants should not be less than required to control erosion.

Cropland and Bio-oil fuel Cropland. the success of crop production from the mined area should be equal to or greater than that of the approved standard for the crop being grown over last two (2) consecutive growing seasons of the five growing season liability period. The applicable five growing season period of responsibility for revegetation should commence at the date of initial planting of the crop being grown.

Forestland post mining land use, a West Virginia registered professional forester should develop a planting plan for the permitted area that meets the requirements of the West Virginia Surface Coal Mining and Reclamation Act. Success of vegetation should be determined based on tree and shrub survival and ground cover. Minimum standards should be seventy percent (70%) ground cover of legumes and perennial grasses, and four hundred fifty (450) trees (including volunteer tree species) and/or planted shrubs per acre for the growing season of the last year of the responsibility period. Substandard areas should not exceed one-fourth (1/4) acre in size nor total more than twenty percent (20%) of the area seeded or planted.

At the time of final bond release, at least eighty (80) percent of all trees and shrubs used to determine revegetation success must have been in place for at least sixty (60) percent of the applicable minimum period of responsibility. Trees and

shrubs counted in determining such success should be healthy and should have been in place for not less than two (2) growing seasons.

Fish & Wildlife and Recreation Lands post mining land use, A professional wildlife biologist employed by the West Virginia Division of Natural Resources should develop a planting plan that meets the requirements of the West Virginia Surface Coal Mining and Reclamation Act. Success of vegetation should be determined based on tree and shrub survival and ground cover. Minimum standards should be seventy percent (70%) ground cover of legumes and perennial grasses, and four hundred fifty (450) trees (including volunteer tree species) and/or planted shrubs per acre for the growing season of the last year of the responsibility period. Substandard areas should not exceed one-fourth (1/4) acre in size nor total more than twenty percent (20%) of the area seeded or planted.

For a wildlife planting plan developed by a professional wildlife biologist that proposes a stocking rate of less than four hundred fifty (450) trees and shrubs per acre. The standard for ground cover grasses and legumes should be ninety percent (90) ground cover and a productivity level as set forth by the Secretary during any two years of the responsibility period except for the first year.

At the time of final bond release, at least eighty (80) percent of all trees and shrubs used to determine revegetation success must have been in place for at least sixty (60) percent of the applicable minimum period of responsibility. Trees and shrubs counted in determining such success should be healthy and should have been in place for not less than two (2) growing seasons.

Commercial Forestry post mining land use, where forest cover is managed for commercial production of timber products. A West Virginia registered professional forester should develop a planting plan and a long-term management for the permitted area that meets the requirements of the West Virginia Surface Coal Mining and Reclamation Act.

Commercial reforestation operations Forest resource conservation standards for commercial reforestation operations are as follows:

The minimum planting rate of commercial tree species in no case may be less than four hundred fifty (450) stems per acre of commercial tree species.

Success of vegetation should be determined based on tree and shrub survival and ground cover. Minimum standards should be  $\geq$  three hundred (300) trees per acre or the rate specified in the forest management plan and there is seventy percent (70%) herbaceous cover during the growing season of the last year of the responsibility period.

At the time of final bond release, at least eighty (80) percent of all trees and shrubs used to determine revegetation success must have been in place for at least

sixty (60) percent of the applicable minimum period of responsibility. Trees and shrubs counted in determining such success should be healthy and should have been in place for not less than two (2) growing seasons.

A request for phase II bond release should not be approved before the end of the fifth tree growing season.

Commercial forestry areas, phase III bond release may not be authorized unless commercial forestry productivity has been achieved by the end of the twelfth growing season or if such productivity has not been achieved a commercial forestry mitigation plan is submitted to the Secretary approved and completed.

# Attachment 1

## NRCS West Virginia Noxious and Invasive Weed Lists

### WV NOXIOUS WEED LIST

As a result of Executive Order 13112 NRCS is required to prevent the introduction and/or spread of invasive species. An invasive species is an alien species whose presence does or is likely to cause economic or environmental harm or harm to human health. Alien species means species not native to a particular ecosystem. Invasive species may include all terrestrial and aquatic life forms including plants, animals, and fungi. NRCS shall not authorize, fund or carryout actions which it believes shall cause or promote the introduction or spread of invasive species in the United States or elsewhere.

Compliance with the Noxious Weed Act of WV means "no person shall move, transport, deliver, ship or offer for shipment into or within this state any noxious weed without first obtaining a permit from the Department of Agriculture and such permit shall be issued only after it has been determined that the noxious weed is generally present throughout the state or is for scientific purposes subject to prescribed safeguards."

Planners should consider if an action or activity will occur in an area where there are significant stands\* of listed invasive species, where they are known to occur, or where there is a significant risk of invasion\* of new populations of listed species. Or, does the activity involve transportation, delivery or shipment of a plant species listed below as a "WV Noxious Weed" or a "Federal Noxious Weed"?

\* A "**significant stand**" is defined in this document as a stand of identified noxious or invasive weed(s) (listed below), where the presence of this species is detrimental to, or interfering with, the intended plant community and may prevent the client from meeting an objective. "**A significant risk of invasion**" is defined as a stand of listed noxious or invasive weed(s) regardless of size, where in the opinion of the planner, if left unchecked is likely to cause adverse or detrimental effects on the intended plant community and result in the client not meeting an objective.

Common Name	Scientific Name	US Nativity	Classification
marijuana *	<i>Cannabis sativa</i> L.	Introduced	WV Noxious Weed
plumeless thistle	<i>Carduus acanthoides</i> L.	Introduced	WV Noxious Weed
curled thistle	<i>Carduus crispus</i> L.	Introduced	WV Noxious Weed
musk thistle	<i>Carduus nutans</i> L.	Introduced	WV Noxious Weed
autumn olive	<i>Elaeagnus umbellata</i> Thunb.	Introduced	WV Noxious Weed
opium poppy *	<i>Papaver somniferum</i> L.	Introduced	WV Noxious Weed
kudzu	<i>Pueraria montana</i> (Lour.) var. <i>lobata</i> (Willd.)	Introduced	WV Noxious Weed
	<i>P. thunbergiana</i> (Sieb. & Zucc.) Benth.		
multiflora rose	<i>Rosa multiflora</i> Thunb. ex Murr.	Introduced	WV Noxious Weed
Johnsongrass	<i>Sorghum halepense</i> (L.) Pers.	Introduced	WV Noxious Weed
giant hogweed	<i>Heracleum mantegazzianum</i>	Introduced	WV Noxious Weed
purple loosestrife	<i>Lythrum salicaria</i>	Introduced	WV Noxious Weed
mile-a-minute	<i>Polygonum perfoliatum</i> L.	Introduced	WV Noxious Weed
Japanese knotweed	<i>Polygonum cuspidatum</i> Sieb. & Zucc.	Introduced	WV Noxious Weed
tree-of heaven	<i>Ailanthus altissima</i> (P. Mill.) Swingle	Introduced	WV Noxious Weed
Japanese stiltgrass	<i>Microstegium vimineum</i>	Introduced	WV Noxious Weed
Tatarian honeysuckle	<i>Lonicera tatarica</i>	Introduced	WV Noxious Weed
Morrow's honeysuckle	<i>Lonicera morrowi</i>	Introduced	WV Noxious Weed
poison hemlock	<i>Conium maculatum</i>	Introduced	WV Noxious Weed
Federal Noxious Weed #	All plants listed under this Act are considered WV Noxious Weeds		

\*These plants have additional laws associated with them. Possession or intentional propagation of these plants may be punishable under State and Federal drug laws and statutes.

## NRCS West Virginia Noxious and Invasive Weed Lists

### WV NRCS ADVISORY LIST

The following plant and animal species have been identified by various state agencies (WVDNR & WVDA) as exhibiting invasive characteristics and should be considered during planning. This advisory list is published by USDA NRCS West Virginia to inform clients of potential risks associated with some species known to exhibit invasive behavior in certain habitats. NRCS West Virginia may recommend their control/eradication when they impair or threaten to impair the intended management of a habitat or intended land use. This list is neither regulatory nor all-inclusive and many other species could be considered invasive. Care should be exercised when implementing practices to avoid the spread of these species and clients should be made aware of their presence during planning.

PLANT SPECIES		
Common Name	Scientific Name	Classification
<a href="#">common reed</a>	<i>Phragmites australis (Cav.) Trin. ex Steud</i>	Potentially Invasive
<a href="#">garlic mustard</a>	<i>Alliaria petiolata</i>	Potentially Invasive
<a href="#">Japanese barberry</a>	<i>Berberis thunbergii</i>	Potentially Invasive
<a href="#">paulownia</a>	<i>Paulownia tomentosa (Thunb.) Sieb. &amp; Zucc.</i>	Potentially Invasive
<a href="#">water milfoil</a>	<i>Myriophyllum spicatum L.</i>	Potentially Invasive
<a href="#">yellow iris</a>	<i>Iris pseudacorus</i>	Potentially Invasive
ANIMAL SPECIES		
Common Name	Scientific Name	Classification
<a href="#">zebra mussel</a>	<i>Dreissena polymorpha</i>	Potentially Invasive
<a href="#">snakehead fish</a>	<i>Channa argus</i>	Potentially Invasive
<a href="#">European gypsy moth</a>	<i>Lymantria dispar L.</i>	Potentially Invasive
<a href="#">emerald ash borer</a>	<i>Agrilus planipennis</i>	Potentially Invasive
<a href="#">hemlock woolly adelgid</a>	<i>Adelges tsugae</i>	Potentially Invasive

# [Federal Noxious Weed List](#) - The APHIS Federal noxious weed program is designed to prevent the introduction into the United States of non-indigenous invasive plants and to prevent the spread of newly introduced invasive plants within the United States. APHIS noxious weed activities include exclusion, permitting, eradication of incipient infestations, survey, data management, public education, and (in cooperation with other agencies and state agencies) integrated management of introduced weeds, including biological control.

The Weed Program Mission Statement: APHIS will use modern technologies to prevent the introduction of parasitic-plant pests and noxious weeds (federally listed or candidates) into the United States. APHIS will exclude, detect, and eradicate newly introduced weeds that pose the highest risk to US agriculture or the environment. APHIS may cooperate with other agencies to achieve environmentally sound and desirable forms of integrated management against introduced invasive plants. Below is a link to Federal noxious weed list.

<http://plants.usda.gov/java/noxious?rptType=Federal>

## Attachment 2

### Information and Recommendations on Legume and Grass Species

It is a general recommendation that Fescues, lespedeza and vetches along with any aggressive species be avoided, unless a permanent herbaceous ground cover is desired. It is recommended that invasive species be avoided always. It should be noted that Kentucky 31 Fescue, seresia lespedeza, all vetches, all clovers (except Ladino and white clover) and other aggressive or invasive species are prohibited on Forestland, Commercial Forestry, and Fish and Wildlife Habitat and Reclamation lands, post mining land use. The following plant species do not create a conclusive list as other species could be acceptable as well as appropriate. The seeding rates (in a mixture) and times are recommendations only and not requirements.

<b><u>Perennial Legumes</u></b>	<b>Seeding rate</b>	<b>Best seeding times</b>
Red clover	8 lbs/acre	Spring and Fall
Birdsfoot trefoil	8 lbs/acre	Spring and Fall
Alsike Clover	6 lbs/acre	Spring and Fall
White clover	3 lbs/acre	Spring and Fall
Ladino clover	3 lbs/acre	Spring and Fall
Partridge Pea	15 lbs/acre	Late Winter and spring
Cowpea	25 lbs/acre	Late Spring Early Summer
Japanese Clover	15 lbs/acre	Early Spring
Sweet Clover	0.25 lbs/acre	Fall; scarified for other times

### Perennial Grasses

#### Cold Season Grasses

Deer tongue	3 lbs/acre	Early Spring; Fall or Winter
Orchardgrass	6 lbs/acre	Early Spring and Late Fall
Perennial ryegrass	10 lbs/acre	Late Spring and Late Summer
Redtop	2 lbs/acre	Spring and Late Summer
Timothy	4-6 lbs/acre	Spring and Fall

Smooth Bromegrass	5-10 lbs/acre	Spring and Fall
Reed Canarygrass	3 lbs/acre	Spring
<u>Warm Season Grasses</u>		
Weeping lovegrass	2 lbs/acre	Late Spring
Little Bluestem	4lbs/acre	Early Spring
Big Bluestem	3 lbs/acre	Late Spring
Indiangrass	2 lbs/acre	Late Spring
Switchgrass	2 lbs/acre	Spring
Eastern Gammagrass	10 lbs/acre	Late Spring
<b><u>Annuals</u></b>	<b>Seeding rates</b>	<b>Best seeding times</b>
Oats	60-90 lbs/acre	Spring and Fall
Wheat	15 lbs/acre	Fall
Rye	60 lbs/acre	Fall
Buckwheat	14 lbs/acre	After frost
Annual ryegrass	15-25 lbs/acre	Early Spring and Late Summer
Foxtail Millet	5 lbs/acre	Spring and Fall

Example of ground cover prescriptions For PMLU of permanent herbaceous ground cover no woody vegetation (trees or shrubs) in planting plan.

Grasses: Orchardgrass 10 lb/acre Tall fescue 10 lb/acre Timothy 5 lb/acre  
Redtop 3 lb/acre

Legumes: Birds-foot trefoil 8lb/acre Kobe lespedeza 8lb/acre

Clovers : Red clover 10lb/acre White clover 3lb/acre

Optional Nurse Crop: Annual rye 25 lb/acre

### Attachment 3

List of native tree species and planting information.

Species	Latin	Leaf Type <sup>a</sup>	Site Type	Potential crop tree? <sup>b</sup>	Growth Rate <sup>c</sup>	N Fixer?	pH Range <sup>d</sup>	Cli-mate <sup>e</sup>
boxelder	<i>Acer negundo</i>	d	wet		rapid		M-H	
red maple	<i>Acer rubrum</i>	d	all	see note	rapid		L-M-H	
sugar maple	<i>Acer saccharum</i>	d	moist, flat	yes	slow		L-M-H	C
gray alder	<i>Alnus incana</i>	d	wet		rapid	M	M	
speckled alder	<i>Alnus incana</i> ssp. <i>rugosa</i>	d	wet		mod.	L	L-M-H	
hazel alder	<i>Alnus serrulata</i>	d	wet		rapid	M	M	
mountain alder	<i>Alnus viridis</i> ssp. <i>crispa</i>	d	wet		mod.	L	L-M-H	
allegheeny serviceberry	<i>Amelanchier laevis</i>	d	moist, flat		mod.		L-M-H	
false indigo bush	<i>Amorpha fruticosa</i>	d	moist		slow	M	L-M-H	
yellow birch	<i>Betula alleghaniensis</i>	d	moist, flat		slow		L-M-H	C
sweet birch	<i>Betula lenta</i>	d	moist, flat		mod.		L-M	
river birch	<i>Betula nigra</i>	d	wet	yes	rapid		L-M	W
bitternut hickory	<i>Carya cordiformis</i>	d	moist, flat	see note	slow		L-M-H	
pignut hickory	<i>Carya glabra</i>	d	dry	see note	slow		L-M-H	
shellbark hickory	<i>Carya laciniosa</i>	d	moist, flat	see note	slow		M	
shagbark hickory	<i>Carya ovata</i>	d	moist, flat	see note	slow		L-M-H	
mockernut hickory	<i>Carya tomentosa</i>	d	dry	see note	slow		L-M	
American chestnut	<i>Castanea dentata</i>	d	dry, moist	see note	rapid		L	
northern catalpa	<i>Catalpa speciosa</i>	d	moist, flat		rapid	L	M	
New Jersey tea	<i>Ceanothus americanus</i>	d	dry, moist		slow	L	L-M	
common hackberry	<i>Celtis occidentalis</i>	d	moist, flat		rapid		M-H	
common buttonbush	<i>Cephalanthus occidentalis</i>	d	moist, wet		mod.		L-M-H	
eastern redbud	<i>Cercis canadensis</i>	d	moist, flat		slow		M-H	
silky dogwood	<i>Cornus amomum</i>	d	moist, flat		mod.		M	
flowering dogwood	<i>Cornus florida</i>	d	moist, flat		mod.		L-M-H	
gray dogwood	<i>Cornus racemosa</i>	d	all		mod.		L-M	
American hazelnut	<i>Corylus americana</i>	d	moist, flat		mod.		M	
green hawthorn	<i>Crataegus viridis</i>	d	moist, flat, wet		mod.		L-M-H	
common persimmon	<i>Diospyros virginiana</i>	d	moist, wet		slow		L-M-H	
American beech	<i>Fagus grandifolia</i>	d	moist, flat	see note	slow		L-M-H	
white ash	<i>Fraxinus americana</i>	d	moist, flat	see note	mod.		L-M-H	
green ash	<i>Fraxinus pennsylvanica</i>	d	moist, flat, wet		rapid		L-M-H	
water locust	<i>Gleditsia aquatica</i>	d	wet		mod.	L	M-H	
honeylocust	<i>Gleditsia triacanthos</i>	d	moist, wet		rapid		L-M-H	
Kentucky coffeetree	<i>Gymnocladus dioicus</i>	d	moist, flat		slow	L	M-H	
American witchhazel	<i>Hamamelis virginiana</i>	d	moist, flat		slow		L-M	
American holly	<i>Ilex opaca</i>	e	moist, flat		slow		L-M-H	
common winterberry	<i>Ilex verticillata</i>	d	all		mod.		L-M-H	
black walnut	<i>Juglans nigra</i>	d	moist, flat	see note	rapid		L-M-H	
eastern redcedar	<i>Juniperus virginiana</i>	e	moist, flat		slow		L-M-H	
sweetgum	<i>Liquidambar styraciflua</i>	d	moist, wet	yes	rapid		L-M-H	
yellow-poplar	<i>Liriodendron tulipifera</i>	d	moist, flat, wet	yes	rapid		L-M	
sweet crab apple	<i>Malus coronaria</i>	d	moist, flat		slow		M	
red mulberry	<i>Morus rubra</i>	d	moist, flat		mod.		M	
hophornbeam	<i>Ostrya virginiana</i>	d	moist, flat		slow		L-M-H	
sourwood	<i>Oxydendrum arboreum</i>	d	dry, flat		slow		L-M	
red spruce	<i>Picea rubens</i>	e	moist, flat	yes	mod.		L-M	

pitch pine	Pinus rigida	e	dry		rapid	L		
Species	Latin	Leaf Type <sup>a</sup>	Site Type	Potential crop tree? <sup>b</sup>	Growth Rate <sup>c</sup>	N Fixer?	pH Range <sup>d</sup>	Cli-mate <sup>e</sup>
shortleaf pine	Pinus echinata	e	moist, flat	yes	rapid		L-M	W
eastern white pine	Pinus strobus	e	moist, flat	yes	rapid		L-M	
loblolly pine	Pinus taeda	e	dry	yes	rapid		L-M-H	
Virginia pine	Pinus virginiana	e	dry		rapid		L-M-H	
American sycamore	Platanus occidentalis	d	moist, flat, wet	yes	rapid		L-M	
eastern cottonwood	Populus deltoides	d	moist, wet	yes	rapid		L-M	
bigtooth aspen	Populus grandidentata	d	moist, flat, wet		rapid		L-M	C
American plum	Prunus americana	d	moist, flat		mod.		M	
pin cherry	Prunus pensylvanica	d	moist, flat		rapid		L-M-H	
black cherry	Prunus serotina	d	moist, flat	yes	rapid		L-M-H	C
white oak	Quercus alba	d	dry, moist, flat	yes	slow		L-M	
scarlet oak	Quercus coccinea	d	dry	yes	rapid		L-M	
southern red oak	Quercus falcata	d	dry, flat	yes	mod.		L-M-H	W
bur oak	Quercus macrocarpa	d	dry, moist, flat	yes	mod.			
chestnut oak	Quercus montana	d	dry	yes	slow		L-M	
chinkapin oak	Quercus muehlenbergii	d	dry	yes	mod.		M-H	
pin oak	Quercus palustris	d	moist, wet	yes	rapid		L-M	
northern red oak	Quercus rubra	d	moist, flat	yes	mod.		L-M-H	
Shumard oak	Quercus shumardii	d	dry, flat	yes	mod.		M-H	W
post oak	Quercus stellata	d	dry	yes	slow		L-M	
black oak	Quercus velutina	d	dry	yes	mod.		L-M	
bristly locust	Robinia hispida	d	dry, moist, flat		rapid	M	L-M-H	
black locust	Robinia pseudoacacia	d	all		rapid	M	L-M-H	
black willow	Salix nigra	d	wet		rapid		L-M-H	
American black elderberry	Sambucus nigra ssp. canadensis	d	moist, flat, wet		rapid		L-M-H	
sassafras	Sassafras albidum	d	moist, flat		mod.		L-M-H	
American basswood	Tilia americana	d	moist, flat	yes	mod.		L-M-H	
American elm	Ulmus americana	d	moist, flat	see note	rapid		M-H	
slippery elm	Ulmus rubra	d	moist, flat		rapid		M-H	
highbush blueberry	Vaccinium corymbosum	d	wet		mod.		L-M-H	
southern arrowwood	Viburnum dentatum	d	all		slow		L-M	
blackhaw	Viburnum prunifolium	d	dry, moist		slow		L-M-H	

a Leaf Type: d = deciduous, e = evergreen.

b Notes concerning crop trees: Hickories, American beech, and black walnut have growth forms that are well suited for crop trees, but consistent success in planting these species on coal surface mines has not been demonstrated. Red maple is not recommended for planting because it volunteers readily. American chestnut, white ash, and American elm are well suited as crop trees when healthy but are subject to special considerations due to their susceptibility to pests as described in text.

c Growth Rate: mod = moderate.

d Soil pH range: Trees are grouped by soil pH suitable for the species. L = low (pH<5); M = medium (pH 5-7); H = high (pH>7).

e Climate Suitability. C = does well in cool climates, including northern Appalachia and at higher elevations (>3000 ft) in central and southern Appalachia; W = does well in warm climates, including Appalachia's southern region and parts of central Appalachia. If neither C nor W is specified, the species does well throughout the region.

**Example** of ground cover prescriptions For PMLU requiring tree and shrubs

ground cover mix and seeding rates (pounds/acre) :

**temporary cover** winter wheat (15 lbs/acre), foxtail millet (5 lbs/acre),

**permanent cover** redtop (2 lbs/acre), perennial ryegrass (2 lbs/acre), orchard grass (5 lbs/acre), weeping lovegrass (2 lbs/acre) kobe lespedeza (5 lbs/acre), birdsfoot trefoil (10 lbs/acre), and white clover (3 lbs/acre).

**South- and west-facing slopes with a soil pH of 6.0 or greater, the four grasses in the mixture shall be replaced with 20 lbs/acre of warm-season grasses consisting of the following species:** big bluestem (5 lbs/acre), little bluestem (2 lbs/acre), Indian grass (2 lbs/acre), and switch grass (1 lb/acre)

**Examples of tree species prescriptions (stems per acre)**

Example tree species prescriptions (stems per acre). Use species native to the planting area, and those that are suited to the landscape position of the mine site.

Dry Slopes (south, west)		Flat Sites (and rolling)		Moist Slopes (north, east)		Wet Sites: (riparian)	
<u>Crop trees</u>		<u>Crop Trees</u>		<u>Crop trees</u>		<u>Crop trees</u>	
white oak	200	white oak	100	white oak	100	pin oak	100
scarlet or post oak	100	northern red oak	100	northern red oak	200	american sycamore	100
black oak	100	sugar maple	100	sugar maple	100	sweetgum	100
chestnut oak	100	yellow- poplar	100	yellow poplar	100	silver maple	100
Virginia pine	100	black cherry	100	black cherry	100	willow oak	100
		black walnut	100			river birch	100
<u>Nitrogen fixing tree</u>		<u>Nitrogen fixing tree</u>		<u>Nitrogen fixing tree</u>		<u>Nitrogen fixing tree</u>	
black locust	25	bristly locust	25	bristly locust	25	alder	25
<u>Wildlife trees</u>		<u>Wildlife trees</u>		<u>Wildlife trees</u>		<u>Wildlife trees</u>	
common persimmon	25	flowering dogwood	25	eastern white pine	25	black willow	25
eastern redbud	25	bitternut hickory	25	shagbark hickory	25	silky dogwood	25
mockernut hickory	25	eastern white pine	25	green hawthorn	25	elderberry	25

Below is a link to the Office of Surface Mining website with Forest Reclamation Advisories several documents developed by the ARRI Science team related to reclamation revegetation.

<https://www.osmre.gov/programs/arri/publications>

## Attachment 4

### MEMORANDUM

To: All DMR Employees  
From: Lewis A. Halstead, Deputy Director  
Date: September 2, 2008  
Re: Ground Cover and Productivity Success Standards

This document replaces the 'Productivity and Ground Cover Success Standards' memorandum issued on May 1, 2002 and modified on March 26, 2007.

#### **Ground Cover**

Ground cover success will be evaluated using the Rennie and Farmer technique described in section 3 of "Technical Guides of Reference Areas and Technical Standards for Evaluating Surface Mine Vegetation in OSM Regions I and II" by Robert E. Farmer, Jr. et al, OSM J5701442/TV-54055A, 1981, U.S. Department of the Interior, Office of Surface Mining Reclamation and Enforcement. et al, OSM J5701442/TV-54055A, 1981, U.S. Department of the Interior, Office of Surface Mining Reclamation and Enforcement (OSM Technical Guides). To document ground cover, a tally sheet shall be filed with the Phase II indicating pass/fail of the ground cover.

Other methods may be used if approved by the Secretary. The permittee and the Secretary shall agree on the method for evaluating ground cover and it shall be clearly presented in the Reclamation/Revegetation Plan.

In accordance with 38CSR2-9, the operator is to request a final inspection and final bond release that includes a final vegetative evaluation using approved, statistically valid sampling techniques. Upon receipt of the request, the agency will conduct an inspection to verify the final vegetative evaluation.

#### **Productivity Success Standards**

A. Pasture and Hayland.

The productivity standard for hayland and/or pastureland may be based:

1. On the statewide 12-year average county yields; 1.6 tons dry matter per acre or an animal-unit-month of 3.;
2. Productivity tables found in NRCS soil surveys for the county;

3. Average county yields recognized by the United States Department of Agriculture (USDA), West Virginia Department of Agriculture (WVDA) or West Virginia Extension Service (WVES);
4. Standard developed in cooperation with the permittee, DEP and the USDA, WVDA or WVES for the proposed area; or
5. Alternative standards may be used if approved by the Secretary. The permittee and the Secretary shall agree on the alternative standard and it shall be clearly presented in the Reclamation/Revegetation Plan.

The procedures for evaluating productivity for hayland and/or pastureland may include:

1. Actual yield records or actual animal production;
2. Clip and weigh (See Section 1 of OSM Technical Guides)
3. Pasture Plate (See WVDEP Pasture Plate Method.); or
4. Other methods may be used if approved by the Secretary. The permittee and the Secretary shall agree on the method for evaluating productivity and it shall be clearly presented in the Reclamation/Revegetation Plan

## B. Crop Land

The productivity standard for cropland may be based:

1. On the statewide 12-year average county yields;
2. Yields for reference crops from unmined lands. Reference crop yields shall be determined from the current yield records of representative local farms in the surrounding area;
3. Productivity tables found in NRCS soil surveys for the county;
4. Average county yields recognized by the USDA, WVDA or WVES;
5. Standard developed in cooperation with the permittee, DEP and the USDA, WVDA or WVES for the proposed area;
6. Alternative standards may be used if approved by the Secretary. The permittee and the Secretary shall agree on the alternative standard and it shall be clearly presented in the Reclamation/Revegetation Plan.

The procedures for evaluating productivity for cropland may include:

1. Actual yield or production records;
2. Alternative standards may be used if approved by the Secretary. The permittee and the Secretary shall agree on the alternative standard and it shall be clearly presented in the Reclamation/Revegetation Plan

### **WVDEP Pasture Plate Method**

The method requires a yardstick, a standardized 18-inch square Plexiglas pasture plate (Rayburn and Rayburn 1998), a 12-inch square wire quadrant, a clipper, and sample bags. The pasture plate is suspended from the hand by a suitable cord, and lowered gently onto the sward at the selected sample point. The yardstick is inserted through a 1.5-inch hole

to make contact with the ground, and the distance from the ground to the pasture plate is measured to the nearest half inch. If required, an associated clip is taken by placing the quadrant on the ground after the plate is lifted, and then cutting at ground level all vegetation that is rooted within the quadrant. Clips are dried and weighed.

The WVDEP Pasture Plate Method is calibrated for forage mixes after June 15. Forms for field data collection are attached. Data collection begins with collection of a sufficient number of randomly distributed height measurements. A sufficient number is at least 60 and not more than 200. From these observations a mean plate height is obtained. To estimate the forage mass, this mean (HT) is entered into the following generalized calibration equation:

$$\text{Forage Mass in tons} = 502 \text{ HT} - 9.25 \text{ HT}^2 / 2000$$

Sites with HT of 8.5 inches will have a forage mass of a least 1.6 tons /acre whereas sites with HT of 6.0 inches will have a forage mass of approximately 1.2 tons /acre. Therefore, height alone can be used to screen and eliminate sites. However, if height (HT) is in the range of 6.0 to 8.5 inches, site-specific local calibration (Method L) is to be used.

### Method L

To accomplish the local calibration, Method L, an Excel spreadsheet named “Local Plate Meter Calibration” is used. First, use the sample of 60 to 200 height observations HT across the entire site or representative sub-areas. Construct a distribution of HT and estimate the mean, while still in the field. Next, still in the field, take a series of 16 paired heights (using the standard plate meter) and clipped forage samples (clipped to ground level from a 1 square foot quadrant). These clips should be evenly balanced with half below and half above the mean height. Avoid taking clips from areas with heights that are "outliers" (outside the percentile range from 3 to 97, or more than 2 standard deviations from the mean).

Height values are entered into the spreadsheet on the worksheet page entitled “Site Forage Height”. Clip samples are dried, and dry weights and associated heights are entered on the worksheet page entitled "Height vs. Clipped Forage Mass." In the spreadsheet, sample weights are entered in grams. The spreadsheet calculates forage density for each clipped sample (grams/inch plate height/sqft), calculates the covariance of plate height and clipped forage density, and converts grams to pounds. On the page entitled “Site Summary” the spreadsheet reports the mean forage mass on the site based on the mean site plate height and the mean density of the clipped samples. It calculates the confidence interval of this product from the variance of site plate height, variance of the clipped forage density and covariance between clipped sample plate height and forage density (Freese, 1962).

If the calculated mean site forage mass is equal to or greater than the goal forage mass, the site passes. If the Upper CI on Site Forage Mass (mean site forage mass plus the CI) is greater than the goal forage mass the site passes based on the t-test since this comparison using the CI is simply a rearrangement of the t-test equation of a mean and its variance against a constant.

## References

Freese, F. 1962. Elementary Forest Sampling. Washington, DC, US Department of Agriculture - Forest Service.

Rayburn, E. B. and S. B. Rayburn (1998). "A standardized plate meter for estimating pasture mass in on-farm research trials." Agron. J.( 90): 238-241.

Rayburn, E.B. 1997. An acrylic plastic weight plate for estimating forage yield. WVU-ES TRIM Fact Sheet 5022. <http://www.caf.wvu.edu/~forage/pastplate.htm>

Rayburn, E. B., and J. Lozier. 2003-2004. Reports prepared for West Virginia Department of Environmental Protection on the estimation of forage mass from sward height on West Virginia surface mine sites.

## Attachment 5

The following criteria have been approved by the director for evaluating ground cover, stability and determining standards of success for vegetative cover.

This section contains the sampling procedures and evaluative technique developed for West Virginia to determine revegetation success standards with 90% statistical confidence. This method has been developed from the Rennie-Farmer Method for use in the West Virginia Reclamation Program and is referred to as the "Modified Rennie-Farmer Method". Which can be found at: <https://dep.wv.gov/dmr/handbooks/Documents/OSM%20Technical%20Guides.pdf>

### Recommended Procedures for the Modified Method:

The Modified Method should be employed when the ground cover density on a site appears questionable or contains questionable areas. If, through field observation, it is determined that the site has adequate vegetation (under current state regulations, more than 70 percent cover) or ostensibly has less than adequate vegetation (less than 70 percent cover), the method need not be applied. The purpose of the method is to quantitatively indicate whether an area is or is not adequately vegetated.

The first step to be taken in applying the Modified Method is to determine if sampling is needed and, if so, on what areas of the site. After deciding what areas to sample, determine their acreages, transect spacing's and slope correction factors. On site, the transects and sample plots are oriented and the findings recorded on tally sheets. Calculations, with a hand calculator, can be performed in the field or office.

### Materials Needed to Begin Sampling:

1. Site map and revegetation plan
2. Sampling dowel (44.64 inches long, having 20 equally spaced 1/16- inch rings)
3. Tally sheet and calculation form
4. Tape measure (at least 10 feet long)
5. Table of two-digit random numbers
6. Table of recommended transect spacing's (Table 3)
7. Pencils
8. Calculator
9. Compass (optional)

## **Pre-Sampling Calculations**

### **Step 1** Field Review the Site

Determine whether sampling is needed; if so, proceed to step 2.

### **Step 2** Review the Reclamation Plans and Maps for the Permit Area

Determine the acreage of the site or areas to be sampled and the average slope from the site map.

### **Step 3** Determine the Transect Spacing

Locate the acreage from step 2 in Table 3 and record the transect spacing. (see Table 3)

### **Step 4** Determine the Slope Correction Factor

For slopes greater than 10%, use the equation, square root of:  $(1 + (\text{percent slope}/100)^2)$  to determine the slope correction factor. (see table 5)

### **Step 5** Determine the Corrected Transect Spacing

Multiply the transect spacing from step 3 by the slope correction factor in step 4.

### **Step 6** Determine the Corrected Milliacre Plot Radius

Multiply the slope correction factor from step 4 by 44.64 inches. This answer will be the radius of the milliacre plots used to determine woody stem counts.

## Sampling Procedures

### **Begin Sampling at One End of the Site**

#### **Step 7** Determine the Beginning Point of the First Transect

Pace off the distance (from step 5) along the perimeter of the site to the beginning point of the first transect.

#### **Step 8** Orient the Transect

Pick a direction which will allow traversing the slope (if there is one) at a diagonal (see Figure (1)). A compass may be used, or two or more distant objects chosen to help maintain a straight transect.

#### **Step 9** Determine the Distance to the First Sample Plot

Using the table of random two-digit numbers (see Table 4), select the next number and pace off this distance to the first sampling point. (Note that the distances listed are measured in steps, not feet. A step is whatever distance is comfortable, whether it is 2.2 feet or 3 feet, as long as the distance of the step remains constant.)

**Step 10** Sample the Plot

To sample, slide the measuring dowel beneath the vegetation perpendicular to the transect and read the number of hits along the far edge of the dowel. A hit is counted only if living vegetation is found directly above, below, touching or within a 1/16-inch-diameter window as viewed from above the mark on the dowel (see Figures 2 and 3). Do not count a hit if the only vegetation present is algae, since their ability to prevent erosion is very limited.

**Step 11** Record the Hits on the Tally Sheet

Using dots, record the hits (as illustrated in Figure 9). This method requires only a few seconds per sampling point.

**Step 12** Determine the Presence of Woody Stems

To check for the presence of woody stems in a milli-acre plot, rotate the dowel 360° from the transect, as in Figure 4. Note that the sampling dowel, as marked, is only 44.64 inches in length and is the radius of a milli-acre plot only on flat land. To measure the radius of a plot on a slope, use the radius calculated in Step 6. (A 60-inch length dowel can be temporarily marked for slopes of up to 89 percent. Beyond this slope, one would have to use a tape measure and a nail to form a pivot point to measure the correct radius. A 200 percent slope requires a radius of 100 inches.)

**Step 13** Determine the Next Sample Plot

Select the next random number and pace off the distance to the next sampling point and repeat the procedures from Step 10. If the end of a transect is reached before reaching the next sampling point, lightly record the remaining distance to continue pacing after the next transect has been positioned, thus carrying over one sample point to the next transect. There is no need to discard or neglect the remaining distance as in the Rennie-Farmer Method.

**Step 14** Locate and Orient the Next Transect

To find the next transect, turn 90° or walk along the perimeter and pace off the predetermined distance to the next transect. The second and all remaining transects should be kept parallel to the first transect. If the topography will not allow this, try to keep parallel as many transects as possible. For example, transects 1-3 may be parallel to each other but, due to circumstance, not parallel to the remaining transects. The important point to keep in mind is that whatever is done should be done in such a manner as not to bias the method or areas to be sampled.

**Step 15** Continue Sampling

Repeat the above steps until the site has been sampled.

**Post-Sampling Calculations:**

Post-Sampling calculations, easily handled with a pocket calculator, may be performed on or off the site. Figure 10 illustrates the calculation forms which contain the step-by-step directions.

The mean is the most important calculation. When divided by 20, it will yield the percent cover.

**Measuring Cover Crop on Revegetated Haul Roads and Similar Narrow Areas:**

To begin, pick a starting point at the beginning of the haul road along the perimeter. This will be the starting point of transect. Select a random number from the table of two-digit random numbers and pace off this distance at a diagonal toward the opposite perimeter. If you reach the opposite perimeter before the spacing is complete, turn 90° and continue spacing. The object is to traverse the haul road with short transects that are at right angles to each other and continue to sample spacing from one transect to the next (see Figure 8). After reaching the sample point, the recordation continues as in the Modified Method. However, continue the random spacing and right-angle transect setup until the end of the haul road is reached.

This method is to be applied to revegetated haul roads or other narrow areas of less than 100 feet in width.

**TABLE 3**

**TRANSECT SPACING AREA**

<b>Acres</b>	<b>Transect Feet</b>	<b>Spacing Steps</b>
1	31	13
2	44	18
3	53	21
4	63	25
5	70	28
6	76	30
7	82	33
8	88	35
9	94	38
10	99	40
12	107	43
14	116	46
16	124	49
18	132	53
20	139	56
25	155	62
30	170	68
35	184	73
40	197	79
45	208	84
50	221	88

**TABLE 4**

**TABLE OF TWO-DIGIT RANDOM NUMBERS**

52	45	25	59	67	92
89	27	48	52	80	36
64	89	89	85	20	62
37	34	25	62	31	86
65	70	99	83	50	93
50	24	47	24	69	86
57	51	52	76	30	11
32	89	76	53	66	35
52	42	21	83	55	60
49	39	57	52	80	28
90	37	77	56	10	56
80	11	54	14	72	95
28	75	96	19	74	41
50	47	48	49	76	66
46	24	76	48	52	99
72	94	56	62	31	43
40	38	98	37	23	15
25	96	68	91	93	86
22	14	40	25	42	52
47	55	45	39	16	79
94	99	49	56	29	33
15	24	19	98	97	38
10	63	37	79	86	29
50	47	93	41	21	58

**TABLE 5**

**Correction factors to calculate distances along various slopes that correspond to desired horizontal distances. (For example, to go a horizontal distance of 63 feet on a slope of 53 percent, you would measure a distance of 71 feet (1.13 x 63) along the slope.)**

Limits of slope percentage	Correction factor	Limits of slope percentage	Correction factor	Limits of slope percentage	Correction factor
		55.8		80.7	
	1.01		1.15		1.29'
		57.8		82.3	
	1.02		1.16		1.30,
		59.8		83.9	
	1.03		1.17		1.31'
26.7		61.7		85.4	
	1.04		1.18		1.32
		63.6		86.9	
	1.05		1.19		1.33
		65.4		88.4	
	1.06		1.20		1.34
		67.2		89.9	
	1.07		1.21		1.35
		69.0		91.4	
	1.08		1.22		1.36
		70.8		92.9	
	1.09		1.23		1.37
		72.5		94.3	
	1.10		1.24		1.38
		74.2		95.8	
	1.11		1.25		1.39
49.3		75.8		97.2	
	1.12		1.26		1.40
51.5		77.5		98.7	
	1.13		1.27		1.41
		79.1		100.1	
	1.14		1.28		1.42
		80.7		101.5	

Correction factor for steeper slopes is:

$$\text{Square root of: } (1 + (\text{Slope percentage}/100)^2)$$

From: Space, J. C. 3-P Forest Inventory: Design, Procedures Data Processing. USDA Forest Service, Stater and Private Forestry - Southeastern Area, Atlanta.

**FIGURE 1**

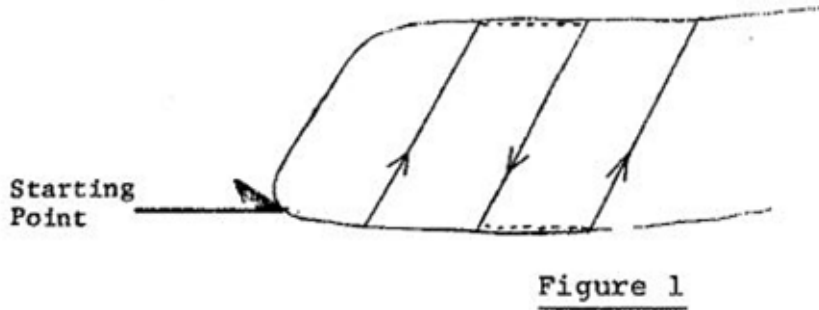

**FIGURE 2**

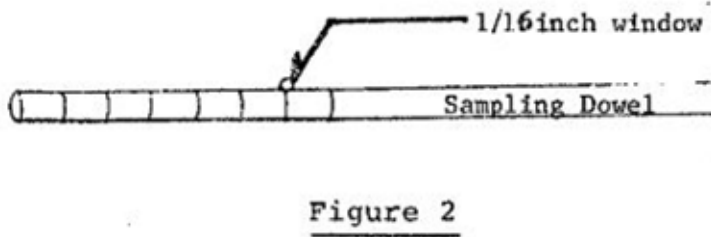

**FIGURE 3**

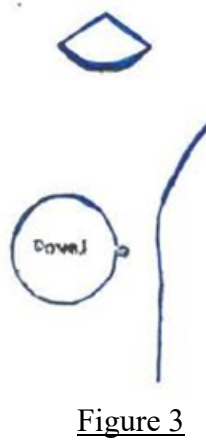

**FIGURE 4**



Figure 4

**FIGURE 5**

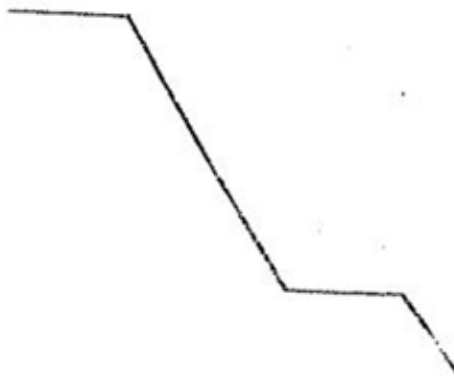

Figure 5

**FIGURE 6**

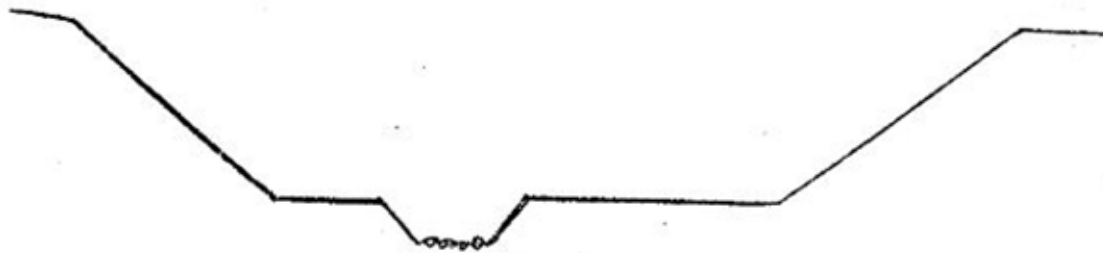

Figure 6

PS50-77  
CROSS-SECTION

**FIGURE 7**

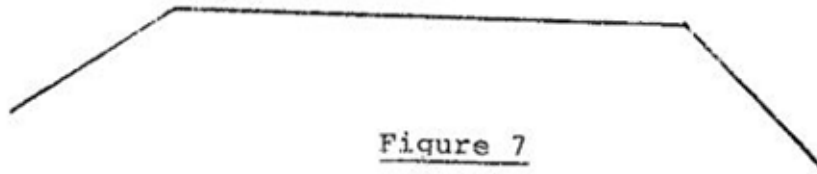
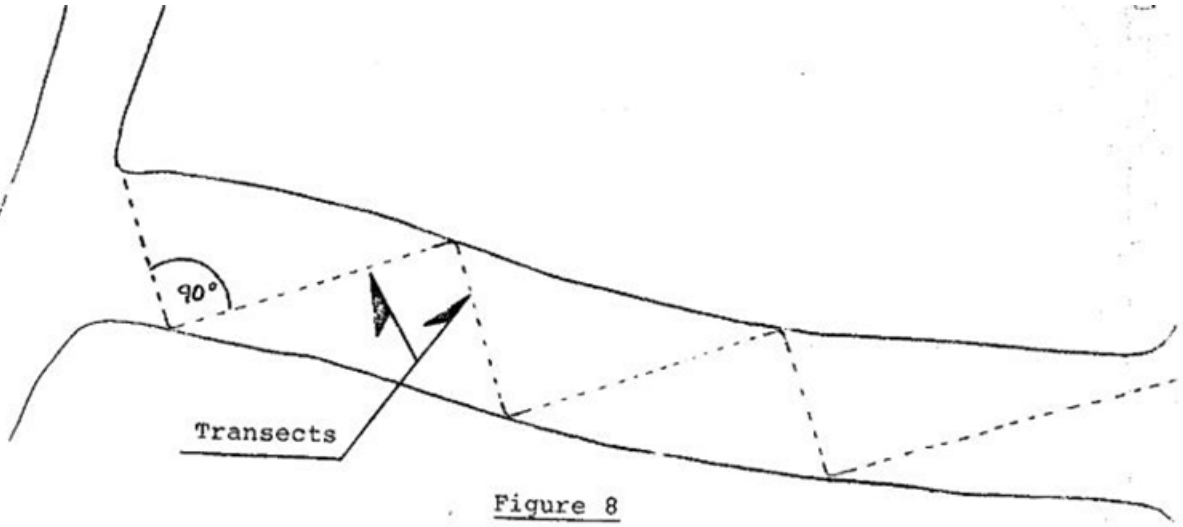

Figure 7

VC16-75  
CROSS-SECTION

**FIGURE 8**



Right Angle-Method of Sampling Revegetated Haul Roads

**FIGURE 9**

**Tally Form for Strip- Mine Revegetation Sample (Use one form for each area sampled).**

**Sample Area:** \_\_\_\_\_ **Date:** \_\_\_\_\_ **By:** \_\_\_\_\_

A. Woody Plant Stoking: For every plot with one or more live tree, woody shrub, or woody vine, mark lowest unmarked number with an X, otherwise circle lowest unmarked number:

1	2	3	4	5	6	7	8	9	10	11	12	13	14	15	16	17	18
19	20	21	22	23	24	25	26	27	28	29	30	31	32	33	34	35	36
37	38	39	40	41	42	43	44	45	46	47	48	49	50	51	52	53	54
55	56	57	58	59	60	61	62	63	64	65	66	67	68	69	70	71	72
73	74	75	76	77	78	79	80	81	82	83	84	85	86	87	88	89	90
91	92	93	94	95	96	97	98	99	100	101	102	103	104	105	106	107	108
109	110	111	112	113	114	115	116	117	118	119	120	121	122	123	124	125	126
127	128	129	130	131	132	133	134	135	136	137	138	139	140	141	142	143	144
145	146	147	148	149	150	151	152	153	154	155	156	157	158	159	160	161	162
163	164	165	166	167	168	169	170	171	172	173	174	175	176	177	178	179	180

- B. Ground Cover: Tally each line transect in the row corresponding to the number of marks or pins out of 20 that intersect live vegetation.

### Dot-Dash Tally Method

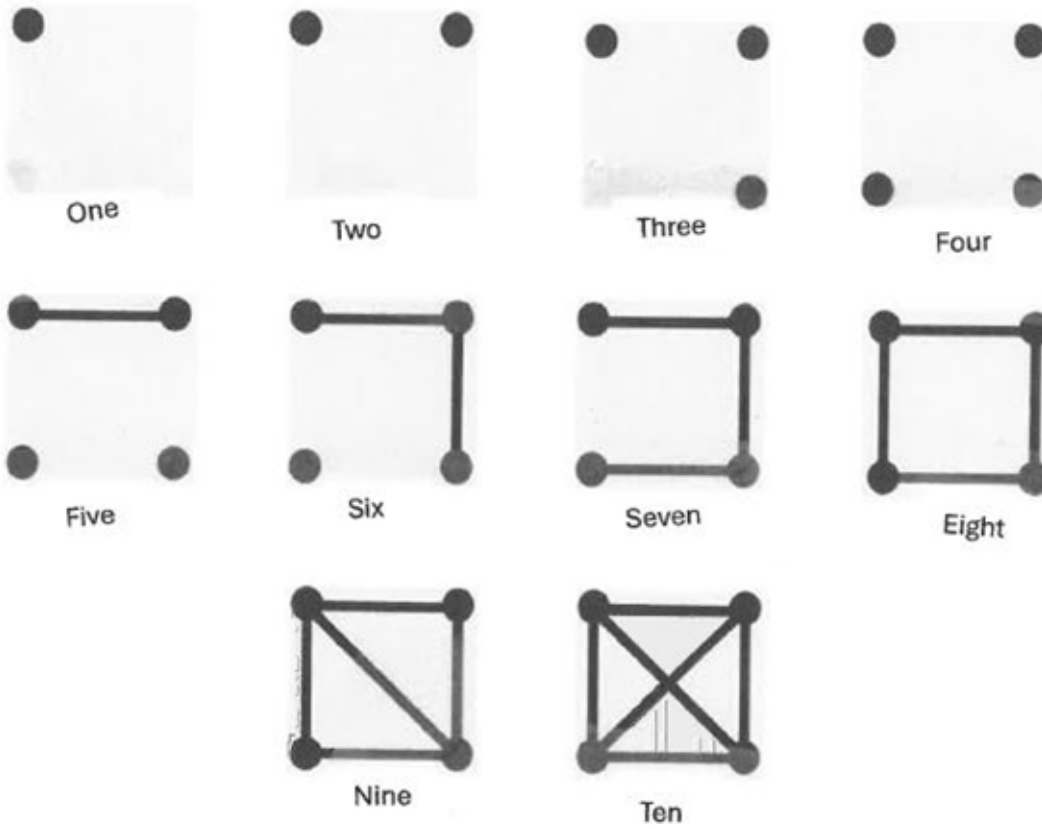

Column 1	Column 2	Column 3	Column 4	Column 5	Column 6	Column 7
No. of Pins or Marks out of 20 Vegetated	Tally for Sample Points	Number of Points Tallied		C3 x C4		C3 x C6
0			0		0	
1			1		1	
2			2		4	
3			3		9	
4			4		16	
5			5		25	
6			6		36	
7			7		49	
8			8		64	
9			9		81	
10			10		100	
11			11		121	
12			12		144	
13			13		159	
14			14		196	
15			15		225	
16			16		256	
17			17		289	
18			18		324	
19			19		361	
20			20		400	

**FIGURE 10**

Calculation Form for Strip Mine Revegetation Sample on steep slopes (use one form for each area sampled).

SAMPLE AREA: \_\_\_\_\_ DATE: \_\_\_\_\_ BY: \_\_\_\_\_

**A. WOODY PLANT STOCKING SAMPLE**

	Column 1	Column 2	Column 1	Column 2
1. Count number of stocked plots (X) and record below.	No. of Sample Plots Observed	Minimum No. of Sample Plots Stocked for Adequate Stocking	No. of Sample Plots Observed	Minimum No. of Sample Plots Stocked for Adequate Stocking
2. Count number of unstocked plots (0) and also record.				
3. Sum 1 and 2 to get total number of plots.				
No. of stocked plots: ___ Line 1	50-54 55-59 60-64	25 28 31	115-119 120-124 125-129	62 65 68
No. of unstocked plots: ___ Line 2	65-69 70-74	34 37	130-134 135-139	71 74
Total no of plots: ___ Line 3=1 + 2	75-79 80-84 85-89 90-94 95-99 100-104 105-109 110-114	39 42 45 48 51 53 56 59	140-144 145-149 150-154 155-159 160-164 165-169 170-174 175-179	76 79 82 85 88 91 94 96

4. Locate the range (Column 1) that includes the number of plots you took (Line 3) and record the minimum number of stocked plots needed for adequate stocking from Column 2 on Line 4

5. Is Line 1 equal to or larger than Line 4?  
 \_\_\_ Yes: The area has adequate woody plant stocking.  
 \_\_\_ No: The area lacks adequate woody plant stocking.

---

**B. GROUND COVER SAMPLE**

- On tally form, count the number of plots tallied in Column 2 for each row and record in Column 3.
- For each row on tally form, multiply the number in Column 3 by the number in Column 4 and record in Column 5.
- For each row on tally form, multiply the number in Column 3 by the number in Column 6 and record in Column 7.
- Total Columns 3, 5, and 7; record each sum at the bottom of the column and below:  
 $\Sigma C3 = \underline{\hspace{2cm}}$        $\Sigma C5 = \underline{\hspace{2cm}}$        $\Sigma C7 = \underline{\hspace{2cm}}$
- Calculate the mean:  $\bar{X} = \Sigma C5 / \Sigma C3 = \underline{\hspace{2cm}}$
- Calculate the correction factor:  $cf = \Sigma C5 \times \Sigma C3 / \Sigma C3 = \underline{\hspace{2cm}}$
- Calculate the sum of squares:  $SS = \Sigma C7 - cf = \underline{\hspace{2cm}}$
- Calculate the degrees of freedom:  $df = \Sigma C3 - 1 = \underline{\hspace{2cm}}$
- Calculate the variance:  $V = SS/df = \underline{\hspace{2cm}}$
- Calculate the standard error:  $s.e. = \sqrt{V/\Sigma C3} = \underline{\hspace{2cm}}$
- Circle the appropriate t value: if  $\Sigma C3$  is 60 or less,  $t = 1.303$ ;  
 if  $\Sigma C3$  is between 60 and 120,  $t = 1.296$ ;  
 if  $\Sigma C3$  is more than 120,  $t = 1.289$ .
- Calculate the upper bound on the confidence limit:  $\{\bar{X} + (t \times s.e.)\} = \underline{\hspace{2cm}}$
- Is the results of step 12 equal to 14.0 or more?  
 \_\_\_ Yes: The area has adequate ground cover.  
 \_\_\_ No: The area lacks adequate ground cover.

Figure 10

### References and Literature Cited

Goodall, D.W., "Some Consideration in the Use of Point Quadrants for the Analysis of Vegetation," *Australian J. Sci. Res., Series B5:1-41*, 1952.

Hutchings, Selar S. and Pase, Charles P., *Measurement of Plant Cover-Basal, Crown, Leaf Area*, U.S.D.O.A. Miscellaneous Pub. 140, page 22-30.

Mueller-Dombois, Dieter and Ellenberg, Heinz, *Aims and Methods of Vegetation Ecology*, John Wiley and Sons, N.Y., 1974, pages 80-92.

Poole, Robert W., *An Introduction to Quantitative Ecology*, McGraw Hill, Inc., N.Y., 1974, pages 42-55, 84-100, 112-116.

Smith, Robert L., *Ecology and Field Biology*, Harper and Row, Inc., N.Y., 1966, pages 610-624.

Vogel, Willis G., *A comparison of Three Range Measurement Techniques and a Study of the Response of Native Vegetation to Protection from Sheep Grazing (master's thesis)*, Montana State College, 1960.

*West Virginia Surface Mining Reclamation Regulations, Series VII*, West Virginia Department of Natural Resources, 1981, Chapter 20-6, Section 4F.09.

Rennie, J.C., and Farmer, R.E. Jr., *AML Inventory System For Evaluating Revegetation of Reclaimed Surface Mines to Forest Resource Conservation Standards*, Office of Natural Resources, Tennessee Valley Authority.

Sansoucie, Conrad H., *Cover Crop Measurements on Revegetated Surface Mines in West Virginia: Comparative Results of Modifying the Rennie-Farmer Method for use in West Virginia*, Research Project, for ES 799, by grant from the West Virginia Department of Natural Resources, Division of Reclamation, December 1981.

**TABLE ONE****CLASSIFICATION OF MINESOILS WITHIN SOIL TAXONOMY**

Minesoils of all ages are now being grouped under the category called spoilents. This means recognition that these highly disturbed or manmade soils deserve the same attention, classification and management as other soils.

1. Fieldcrest is a family of Minesoils containing a mixture of rock types. It has an acid but not extremely acid profile. Texture is loamy; mineralogy is mixed and fertility is medium. These are probably the most widespread Minesoils in West Virginia.
  2. Postoak is a minesoil family containing a dominance of mudstone material. It is near neutral in profile reaction; fine loamy textures and relatively fertile.
  3. Widen minesoils are dominated by carbon rich coarse fragments or mine waste. They are acid in reaction but respond well to liming and revegetation.
  4. Brandonville minesoils are dominated by shaly (fissile) coarse fragments. They are loamy in texture, have mixed mineralogy, are moderately acid and moderately fertile.
  5. \*Valley Point minesoils are dominated by sandstone coarse fragments. They are coarse loamy in texture, have siliceous mineralogy, low fertility and are extremely acid. These minesoils provide stable roadways and building sites.
  6. \*Birdcreek minesoils are similar to Vally Point soils but are acid instead of extremely acid.
  7. Killarm minesoils contain a mixture of rock types. The profile is neutral in reaction. Texture is medium loamy. Mineralogy is mixed and fertility (except nitrogen) is relatively high.
  8. Overfield minesoils contain a mixture of rock types. The profile is extremely acid (pH is below 4 at 10 inches). Texture is medium loamy. Mineralogy is mixed. Fertility is medium but acid related toxicity must be remedied by topsoiling or massive liming in order to get desirable plant growth.
  9. Shawneetown minesoils have less than 10% rock fragments in the profile. The reaction is neutral; texture is fine loamy; mineralogy is mixed and fertility is relatively high except for nitrogen. These minesoils are suitable for cultivated cropping, but may not be present in mappable units in West Virginia.
  10. Pursglove minesoils are like Widen except that they are extremely acid and require covering with favorable material or massive liming for satisfactory revegetation.
- Soils 5 and 6 frequently occur together in complex patterns. These ten spoilents cover most but not all minesoils in West Virginia. Other named minesoils have been identified and described and can be classified on request.

## **EXHIBIT 1**

### **TIME OF SEEDING**

#### **Surface Mine Reclamation Areas**

Optimum Times to Seed Are:

February 1 to March 15: Broadcast seed on surface with no mechanical tillage.

April 15 to June 15: Broadcast or seed with a drill on prepared seedbed; mulch following seeding where required.

August 1 to August 31: Broadcast or seed with a drill on prepared seedbed; mulch following seeding.

On disturbed areas where it is difficult to prepare a seedbed, lime should be applied as needed as soon as regrading is complete. Fertilizer and seed can be applied together in a hydroseeder promptly after final grading and preferably before much rainfall. The area should be mulched according to specifications in the rules and regulations. Areas where stand is not satisfactory should be seeded again in six to twelve months.

If backfilling and final grading is completed out of a favorable seeding time apply the required lime and fertilizer and seed with an annual species to stabilize the area until a favorable seeding time is reached. The area should then be tilled, and a perennial grass legume mixture seeded on the area. Annual species are only temporary and will not replace the perennial grasses as required in the rules and regulations.

### Best Seeding Times for Legume and Grass Species

	Spring Seeding March – April	Late Summer Seeding August
<b><u>Perennial Legumes</u></b>		
Alfafa	Yes	Yes
Birdsfoot Trefoil	Yes	Yes
Crown Vetch	Yes	Yes
Sericea Lespedeza	Yes	No
<b><u>Perennial Grasses</u></b>		
Deer Tongue	Yes	No
Orchardgrass	Yes	Yes
Perennial Ryegrass	Yes	Yes
Redtop	Yes	Yes
Tall Fescue	Yes	Yes
Heeping Lovegrass	Yes	No
<b><u>Annuals</u></b>		
Oats	March – April - May	
Wheat	August – September – October	
Rye	September – October – November	
Sudan Grass	May – June – July	
Buckwheat	June – July	
Annual Ryegrass	March – April – May – June – August – September	
Hairy Vetch	August – September	
Sweet Clover	March - April	

**TABLE THREE**  
**APPROVED WOODLAND PLANT MIXTURES**  
**(Nursery Grown Seedlings)**

1.	Black Locust (3000') White Pine	Plant in bands 6 rows or more in width. Black Locust not to exceed 50%
2.	Black Locust (3000') Virginia Pine	Plant in bands 6 rows or more wide. Black Locust not to exceed more than 50%
3.	Scotch Pine White Pine Red Pine (above 2000') Virginia Pine (below 2500')	Use mixture of tow or more if available. Plant in bands of 6 rows or more.
4.	Black Locust (below 3000') Tulip Poplar (below 3000') Sycamore (Below 2500') Red Oak	Use up to ½ Locust with one or more of hardwood species. Plant in bans of 6 or more rows in each species.
5.	Autumn Olive and adapted Pine or hardwoods.	Where owner's interest is pine or hardwoods wildlife improvement, plant in bands of 3 to 6 rows preferable with pines or in blocks of ¼ acre spaced 600' apart.
6.	European Black Alder (below 2500') Sycamore Indigo Bush Autumn Olive	Use these plants where protection from grazing is impractical or protection will not be maintained. For wildlife habitat improvement use 3 to 6 row bands where two or more species are planted.
7.	European Black Alder	Use European Black Alder where pH is near 5.5.
8.	Black Locust	Use only on steep erodible out slopes.
9.	Sweet Crab Apple* Washington Hawthorne*	On bench of areas where owners primary interest is wildlife habitat improvement, plant in clumps of 12 spaces 10' to 12' apart. Clumps should be spaced 200' to 300' apart, planted in between with pine, Indigo Bush or Autumn Olive.
10.	Blackberry*	Plant on bench spaced 6X6 in blocks 100 plants per block.
11.	Grey Dogwood* Silky Cornwell*	On bench near water impoundments spaced 8X8.

\* Should be planted only on the more favorable sites. Preferably north or northeastern aspect with a pH of 5.5 or above.